

# Experimental Investigation on Cold-formed Steel Wall Plate System

A. L. Y. Ng, W. H. Hii

**Abstract**—A series of tests on cold-formed steel (CFS) wall plate system subjected to uplift force at the mid span of the wall plate is presented. The aim of the study was to study the behaviour and identify the modes of failure of CFS wall plate system. Two parameters were considered in these studies: 1) different dimension of U-bracket at the supports and 2) different sizes of lipped C-channel. The lipped C-channels used were C07508, C07512 and C10012. The dimensions of the leg of U-bracket were 50x35 mm and 50x60 mm respectively, where 25 mm clearance was provided to the connections for specimens with clearance. Results show that specimens with and without clearance experienced the same mode of failure. Failure began with the yielding of the connectors followed by distortional buckling of the wall plate. However, when C075 sections were used as wall plate, the system behaved differently. There was a large deformation in the wall plate and failure began in the distortional buckling of the wall plate followed by bearing of the connecting plates at the supports (U-bracket). The ultimate strength of the system also decreased dramatically when C075 sections were used.

**Keywords**—Cold-formed steel, wall plate system, distortional buckling, full scale laboratory test.

## I. INTRODUCTION

IN 2008, a directive issued by Malaysia government makes it compulsory for all government projects to contain 70% Industrialised Building System (IBS) construction concept. Cold-formed steel (CFS) wall plate system is type of IBS construction [1]. It is envisaged that the system has a bright future in the local construction industry.

CFS wall plate system is a structural element known as platform framing which is laid horizontally on concrete roof beam. The system consists of connecting plates (U-bracket and L-brackets), lipped C-channel, screwed and bolted connections as shown in Fig. 1. The system serves as a localised lintel supporting roof trusses and rafters using thin metal.

CFS wall plate system can either fail in the channel, the screwed and bolted connections or the connecting plates (U-bracket or L-bracket) of the system. The channel may fail in local, distortional or flexural buckling in the system [2]. Fig. 2 shows three types of failure mode which may occur in the channel. On the other hand, the modes of failures which may occur in the connection include screw shear, tilting and tearing/bearing [3]. Lastly, failures may occur in the connecting plates. According to Ng and Mei [4], yielding on

L-bracket occurs along the edge of the anchor bolt head when the plate subjected to excessive tension force.

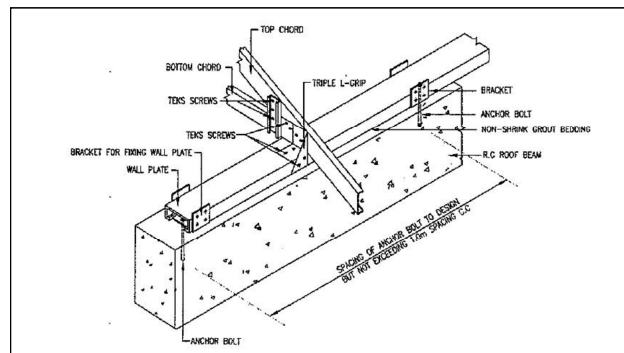

Fig. 1 Steel wall plate system [5]

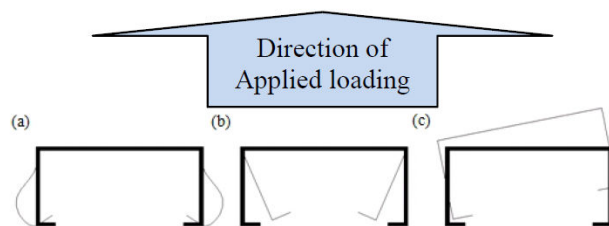

Fig. 2 (a) Local buckling, (b) distortional buckling and (c) flexural buckling for CFS flexural member

The existing studies were mainly targeted on the individual elements mentioned earlier. To the author's best knowledge, no research has been conducted on CFS wall plate system. Thus, the aim of this research is to study the behavior of CFS wall plate system. The study involved experimental investigations on CFS wall plate system and the parameters considered were the sizes of the channel and the dimension of the U-bracket. Only uplift force was considered in the study since uplift force is more critical to fail the system as compared to downward force. Full scale laboratory tests which imitate the actual condition were performed. The bending strengths and failure modes under the tests were observed and compared.

## II. EXPERIMENTAL INVESTIGATION

Schematic diagrams of the tests setup on the CFS wall plate system is as shown in Fig. 3. The test setup was designed to test the most critical situation where failures on the system could occur. Load was applied at the mid span of the wall

A. L. Y. Ng and W. H. Hii are with the School of Engineering, Computing and Science, Swinburne University of Technology (Sarawak Campus), Kuching, Malaysia (e-mail: ang@swinburne.edu.my, whhii@swinburne.edu.my, respectively).

plate, 500 mm from end to supports. U-brackets were used to connect the channel to the support and L-brackets were used to connect the channel to the loading point.

#### A. Test Specimens

In total, 8 specimens were tested in this study under 4 different configurations. At least two specimens were tested for each configuration. Different channel sections namely C07508, C07512 and C10012 were used in the tests. These channels have different depth and thicknesses. The channels have nominal plate thickness ( $t$ ) of 0.8, 1.2 and 1.2 mm and width ( $H$ ) 75, 75 and 100 mm respectively. The nominal depth ( $B$ ) for C075 sections and C100 sections were 40 and 50 mm respectively. The actual dimensions for each of the specimens used were measured at three locations (mid-span and the ends of the channels). The mean dimensions, as determined from the three sets of measurements are tabulated in Table I and the notations used in the table are shown in Fig. 4.

All the connecting plates were cold formed from thin metal plates fabricated from C10012 section. Therefore, the yield strength and ultimate strength of the connecting plates were 585.00 MPa and 587.28 MPa respectively. The dimensions of the plates were measured by electronic caliper for their actual length, thickness and width. All the plates were fabricated according to the tolerance in terms of length and width given in the AS 1391: 2007 [6]. The dimensions or determined measurements are tabulated in Table II and the notations used in the table are shown in Fig. 5.

Screws connections were used to fasten the connections between wall plate and U-bracket. The screws have nominal diameter of 4.36 mm which have drilling capacity up to 4.5 mm metal thickness. The screws have a single shear, axial tensile and torsional capacity of 9 kN, 15.2 kN and 13.5 Nm respectively. The locations of screws used in the connecting plates were marked with a cross ( $\times$ ) as shown in Fig. 5. M16 Grade 8.8 bolts were used. The locations of bolts used in the connecting plates were marked with a circle (O) as shown in Fig. 5. The diameter of the bolt holes is as same as diameter of the bolts used. No clearance was provided to prevent slippage.

#### B. Material Properties

The material properties of the specimens were determined from tensile coupon tests according to AS1391: 2007 [6]. Three tensile coupons were taken from each of the channels; one from the web and two from the flanges. A total of 9 coupons were tested and the results are tabulated in Table II.

### III. TEST RIG AND OPERATION

The test setup for the laboratory test for CFS wall plate system is shown in Fig. 6. U-brackets and L-bracket which were cold formed from thin metal plates were used as connectors to the wall plate at 1m span. A 16 mm diameter bolt was used to fasten the U-bracket to the columns. Load was applied using a universal tensile machine (UTM) through a test rig connected at the mid span of the wall plate. Three numbers of 16 mm diameter bolts were used to fasten the L-bracket to the loading rig. The connection was designed to prevent bearing failure on the L-bracket. Three linear vertical displacement transducers (LVDT) were used to record the vertical deformations of the specimen. Two were placed at each ends of the channel and one at the mid span of the channel. Uplift force was applied at the mid span of wall plate through the loading rig at a constant speed of 10 mm/min.

### IV. PARAMETRIC STUDY

Two parameters were considered in this study; 1) different dimension of U-bracket at the support and 2) different sizes of lipped C-channel. The lipped C-channels used were C07508, C07512 and C10012. The length of the channels was 1400 mm. The connecting plates used had identical nominal thickness ( $t$ ) of 1.2 mm. The width ( $b$ ) of the U-bracket varied depending on the size of the connected wall plate. The dimensions of U-brackets' leg considered were 50x35 mm for specimens without clearance ( $woc$ ) and 50x60 mm for the specimens with clearance ( $wc$ ) where 25 mm clearance was provided to the connection. On the other hand, the dimension for L-bracket were identical, the dimensions considered were 50x50 mm for the shorter leg and 50x180 for the longer leg as shown in Fig. 5.

In the first parametric study, the effect of clearance provided to the wall plate system was studied. The C10012 lipped C-channels and 50x35 mm U-brackets for the specimens without clearance ( $woc$ ) and 50x60 mm U-brackets for specimens with clearance ( $wc$ ) were tested. In the second parametric study, the effect of different sizes of lipped C-channel used to the wall plate system was studied. For this parametric study, 50x60 mm U-brackets were studied throughout the tests with different sizes of lipped C-channels (C07508, C07512 and C10012).

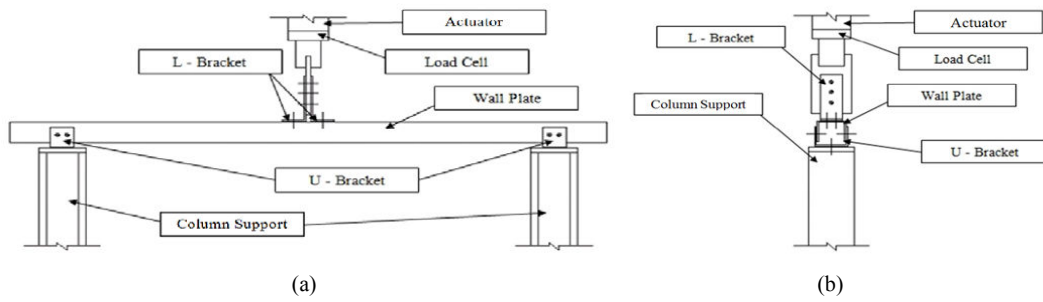

Fig. 3 (a) Front and (b) side view of the proposed test setup

TABLE I  
ACTUAL MEAN DIMENSIONS OF LIPPED C-CHANNEL USED IN THE EXPERIMENTS

Configuration	Channel Section	H (mm)	t (mm)	r (mm)	B <sub>L</sub> (mm)	d <sub>L</sub> (mm)	B <sub>R</sub> (mm)	d <sub>R</sub> (mm)	f <sub>y</sub> (MPa)	f <sub>u</sub> (MPa)
100/1.2/1.2/wc/a	C10012 a	95.35	1.33	1.33	47.05	20.00	47.40	18.10	585.00	587.28
100/1.2/1.2/wc/b	C10012 b	95.45	1.32	1.32	47.70	19.80	47.30	18.30	585.00	587.28
100/1.2/1.2/woc/a	C10012 a	95.50	1.31	1.31	47.20	20.75	47.90	18.80	585.00	587.28
100/1.2/1.2/woc/b	C10012 b	95.90	1.32	1.32	47.00	20.35	47.85	18.20	585.00	587.28
75/1.2/1.2/wc/a	C07512 a	75.50	1.29	1.29	39.30	15.53	39.23	15.56	585.00	587.28
75/1.2/1.2/wc/b	C07512 b	75.46	1.26	1.26	39.12	15.52	39.32	15.52	585.00	587.28
75/0.8/1.2/wc/a	C07508 a	75.73	0.81	0.81	39.82	14.50	41.73	15.50	566.50	568.98
75/0.8/1.2/wc/b	C07508 b	75.90	0.82	0.82	39.80	14.52	41.72	15.51	566.50	568.98

NOTE: Channel width/Channel thickness/Connectors thickness/Configurations with clearance (wo) or without clearance (woc) "a" indicates first test and "b" indicates second test

TABLE II  
ACTUAL DIMENSIONS OF CONNECTORS USED IN THE EXPERIMENTS

Configuration	U-bracket					L-bracket			
	a (mm)	b (mm)	c (mm)	d (mm)	t (mm)	x (mm)	y (mm)	z (mm)	t (mm)
100/1.2/1.2/wc/a	61.03	97.40	61.02	50.05	1.32	50.02	180.01	50.03	1.32
100/1.2/1.2/wc/b	61.02	97.40	61.02	50.03	1.33	50.03	180.02	50.03	1.33
100/1.2/1.2/woc/a	36.02	97.40	36.03	50.02	1.31	50.02	180.00	50.04	1.31
100/1.2/1.2/woc/b	36.01	97.40	36.02	50.01	1.32	50.03	180.02	50.02	1.32
75/1.2/1.2/wc/a	61.03	77.40	61.03	50.00	1.32	50.02	180.02	50.02	1.32
75/1.2/1.2/wc/b	61.02	77.40	61.05	50.00	1.32	50.04	180.03	50.01	1.32
75/0.8/1.2/wc/a	61.04	77.40	61.04	50.02	1.33	50.00	180.02	50.02	1.33
75/0.8/1.2/wc/b	61.05	77.40	61.05	50.03	1.33	50.03	180.02	50.03	1.33

Configuration	U-bracket					L-bracket			
	a (mm)	b (mm)	c (mm)	d (mm)	t (mm)	x (mm)	y (mm)	z (mm)	t (mm)
100/1.2/1.2/wc/a	61.02	97.40	61.03	50.02	1.32	50.02	180.03	50.02	1.32
100/1.2/1.2/wc/b	61.02	97.40	61.02	50.03	1.33	50.03	180.02	50.03	1.33
100/1.2/1.2/woc/a	36.02	97.40	36.02	50.03	1.31	50.02	180.03	50.02	1.31
100/1.2/1.2/woc/b	36.04	97.40	36.02	50.02	1.32	50.03	180.02	50.02	1.32
75/1.2/1.2/wc/a	61.03	77.40	61.02	50.02	1.32	50.02	180.02	50.02	1.32
75/1.2/1.2/wc/b	61.02	77.40	61.03	50.03	1.32	50.03	180.03	50.02	1.32
75/0.8/1.2/wc/a	61.02	77.40	61.02	50.02	1.33	50.03	180.03	50.02	1.33
75/0.8/1.2/wc/b	61.02	77.40	61.03	50.03	1.33	50.03	180.02	50.03	1.33

NOTE: Configuration with clearance (wc) nominal dimensions of the connecting plate's leg were 50x61 and configuration without clearance (woc) nominal dimensions of the connecting plate's leg were 50x36

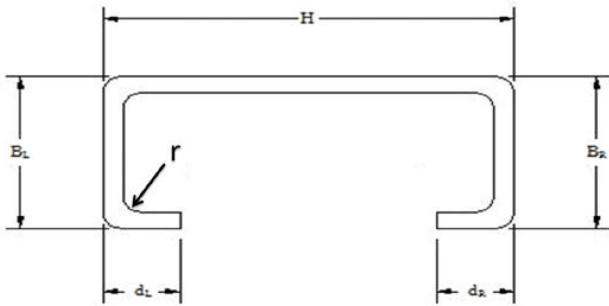

Fig. 4 Definitions for sectional dimensions

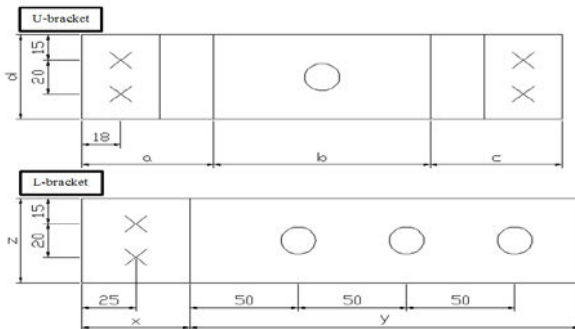

Fig. 5 Definitions and dimension for connecting plates

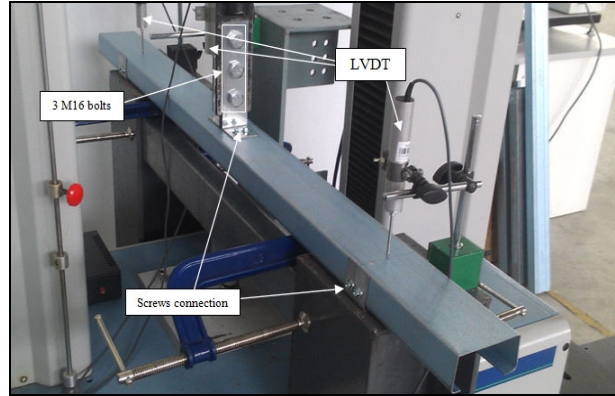

Fig. 6 Test setup for laboratory test on CFS wall plate system

## V. TEST RESULTS

The laboratory test results were summarised in Table III. Included in the table were the first and second modes of failure and the maximum load that could be applied for each configuration. Results show that specimens with and without clearance experienced the same mode of failure. When C100 section was used, failure began with the yielding of the connectors followed by distortional buckling of the wall plate. However, when C075 sections were used as wall plate, the system behaved differently. There was a large deformation in the wall plate and failure began in the distortional buckling of the wall plate followed by bearing of the connecting plates at the supports (U-bracket). The ultimate strength of the system also decreased dramatically when C075 sections were used. The test results are discussed in detail in the subsequent sections.

TABLE III  
OBSERVED FAILURE MODES AND THE MAXIMUM APPLIED FORCE

Configuration	First observed failure mode	Second observed failure mode	Maximum load (kN)
100/1.2/1.2/wc/a	Yielding on connectors (L&U-bracket)	Distortional buckling on wall plate	8.03
100/1.2/1.2/wc/b	Yielding on connectors (L&U-bracket)	Distortional buckling on wall plate	8.01
100/1.2/1.2/woc/a	Yielding on connectors (L&U-bracket)	Distortional buckling on wall plate	8.84
100/1.2/1.2/woc/b	Yielding on connectors (L&U-bracket)	Distortional buckling on wall plate	8.73
75/1.2/1.2/wc/a	Distortional buckling on wall plate	Bearing at connector (U-bracket only)	4.70
75/1.2/1.2/wc/b	Distortional buckling on wall plate	Bearing at connector (U-bracket only)	4.47
75/0.8/1.2/wc/a	Distortional buckling on wall plate	Bearing at connector (U-bracket only)	3.37
75/0.8/1.2/wc/b	Distortional buckling on wall plate	Bearing at connector (U-bracket only)	3.25

### A. Parametric Study 1: Comparison of Specimens With and Without Clearance

Tests were conducted on CFS wall plate system with and without clearance for comparison. Comparison was made between configurations namely 100/1.2/1.2/wc and 100/1.2/1.2/woc. Both of the specimens with (wc) and without (woc) clearance behaved similarly. Failure began with the yielding of the connectors followed by distortional buckling of the wall plate. When a load was applied, the legs of the connecting plates were pulled. The shorter leg of the L-brackets and the web of U-brackets moved upwards. At a load of 2.7 kN, yielding on U and L brackets occurs along the edge

of the bolt head. At around 4.5 kN, the connecting plates were fully stressed as shown in Fig. 7 (a) and distortional buckling began to develop in the channel. The connecting plates at the supports were pulled closer and screws connection at the supports began to tilt. Upon reaching the ultimate load, distortional buckling was fully developed at the mid span of the wall plate as shown in Fig. 7 (b).

The results obtained from the tests were plotted in a load displacement graph. From the graph as shown in Fig. 8, the specimens without clearance have a higher capacity than the specimens with clearance. The differences are influent by stiffness of the supports. For specimens without clearance, the

supports are stiffer and it prevents the connecting plates from moving horizontally. An additional force is required to pull both of the connecting plates closer. In contrast, the specimens with clearance have lower stiffness in their supports.

Therefore, only little force is required to pull both of the connecting plates closer and as a consequence the specimens with clearance have lower ultimate strength.



Fig. 7 (a) First observed failure mode and (b) second observed failure mode in the first parametric study

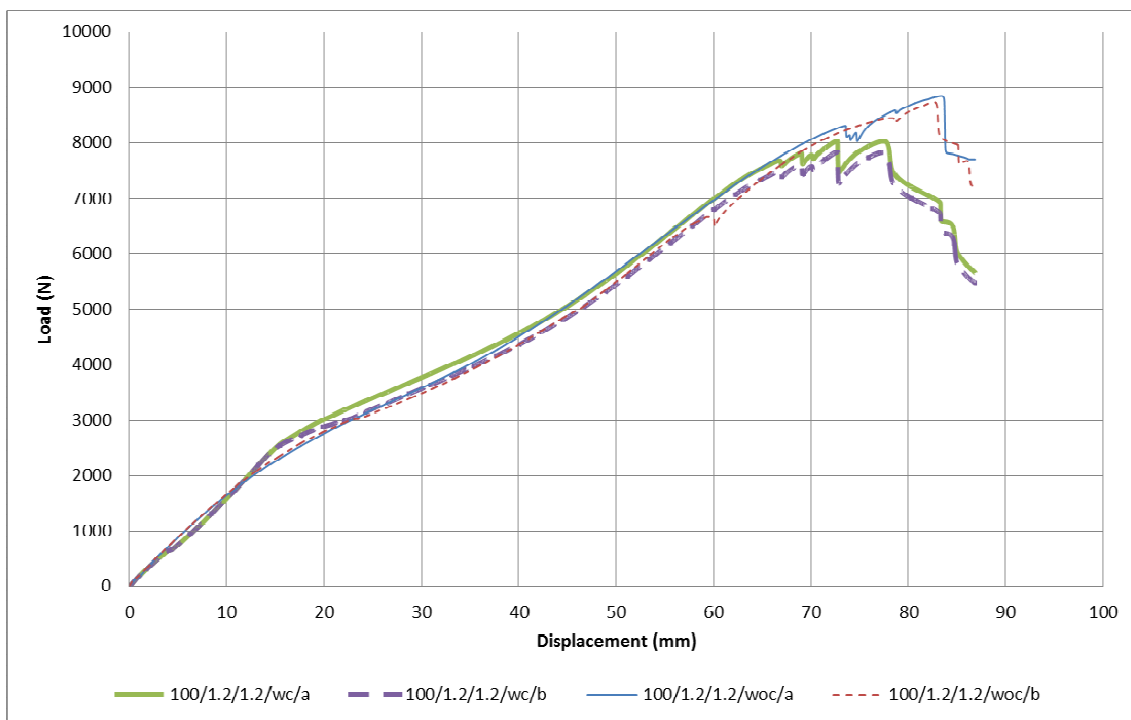

Fig. 8 Load displacement graph for wall plate system with and without clearance

#### *B. Parametric Study 2: Comparison of Specimens with Different Lipped C-channels*

Tests were conducted on CFS wall plate system with different lipped C-channels. The channels had different width and thicknesses. Comparison was made between configurations namely 100/1.2/1.2/wc, 75/1.2/1.2/wc and 75/0.8/1.2/wc. For 100/1.2/1.2/wc, the specimens behaved in a similar manner to the specimens in study 1. Failure began with the yielding of the connectors followed by distortional

buckling of the wall plate. However, when C075 sections were used as wall plate, the system behaved differently. There was a large deformation in the wall plate and failure began in the distortional buckling of the wall plate followed by bearing of the connecting plates at the supports (U-bracket).

It was observed that the C075 lipped C-channels started to bend and at the same time the legs of the U-brackets were pulled when load was applied to the specimen. The shorter leg of the L-brackets and the web of U-brackets moved upwards as shown in Fig. 9 (a). At a load of 2 kN, yielding in the channel

occurred and the U-brackets at the support were pulled closer (yielding on the U-brackets began) and bearing on the screws connections started. Upon reaching the ultimate load, distortional buckling was fully developed at the mid span of the wall plate and yielding of the U-brackets occurred as shown in Fig. 9 (b).

From the graph shown in Fig. 10, the result of the force that was obtained from configuration 100/1.2/1.2/wc was the

highest and the result obtained from the configuration 75/0.8/1.2/wc was the lowest. This was because the cross-sectional area for the wall plate contributed to the total capacity of the wall plate system. C10012 section had the largest cross-sectional area as compared to other wall plates. Thus, configuration 75/1.2/1.2/wc had lower capacity than 100/1.2/1.2/wc and configuration 75/0.8/1.2/wc had the lowest capacity compared to the rest of the configuration.

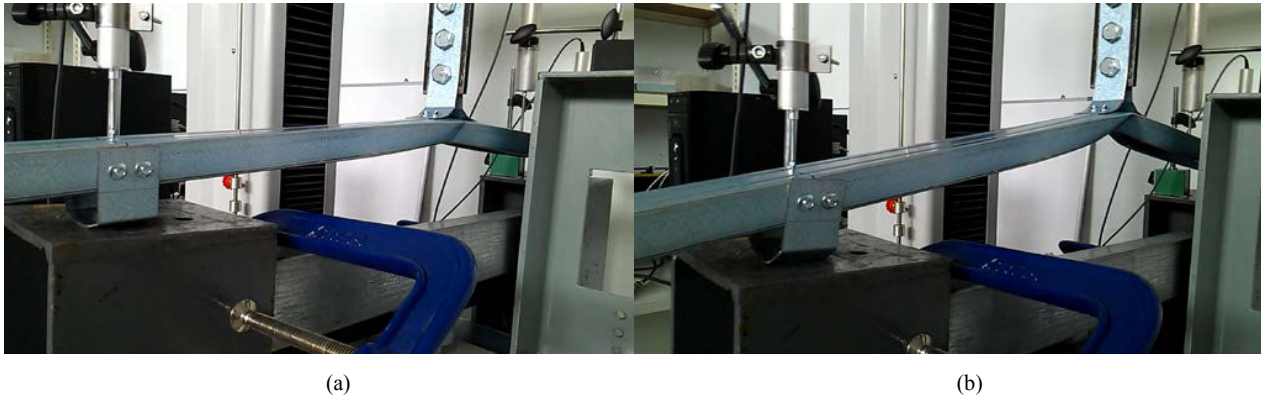

Fig. 9 (a) First observed failure mode and (b) second observed failure mode in the second parametric study

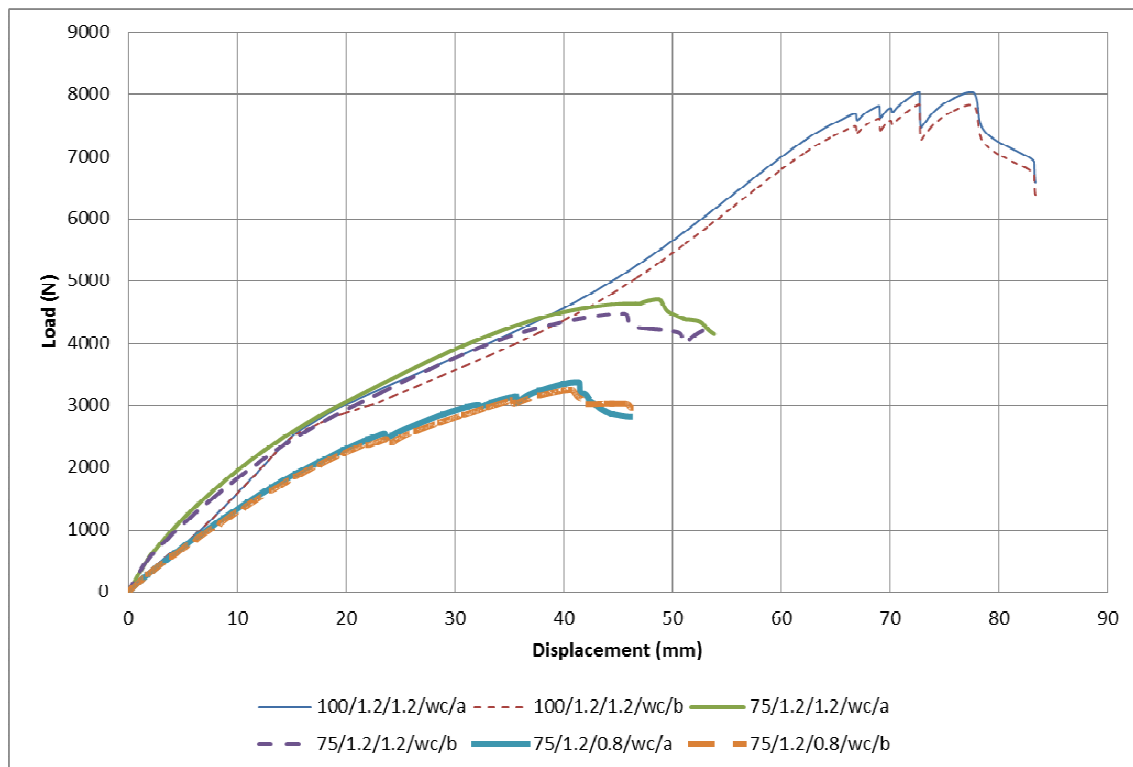

Fig. 10 Load displacement graph for wall plate system with different width and thicknesses of wall plate

## VI. CONCLUSION

When C100 sections were used as wall plates, failure began in the yielding on the connecting plates followed by the distortional buckling of the channel. The wall plate without

clearance had a higher capacity than the wall plate system with clearance. When C075 sections were used as wall plates, failure began in the distortional buckling of the wall plate followed by the bearing failure in the U-brackets. The larger

the lipped C-channels used, the higher the capacity of the wall plate system as a larger channel had a bigger cross-sectional area and stiffness.

#### REFERENCES

- [1] Kementerian Kewangan Malaysia, Pelaksanaan Industrialised Building System (IBS) dalam projek kerajaan, (S/K.KEW/PK/PP/1100/000000/10/31 Jld. 25 SK3 (11)), Kementerian Kewangan Malaysia, Malaysia, 2008.
- [2] H. Wang and Y. Zhang, "Experimental and numerical investigation on cold-formed steel C-section flexural members," *Journal of Constructional Steel Research*, vol. 65, pp. 1225–1235, 2009.
- [3] G. J. Hancock, *Cold-formed steel structures: design of cold-formed steel structures (to AS/NZS 4600:2005)*, 4<sup>th</sup> edn, Australian Steel Institute, Australia, 2007.
- [4] A. L. Y. Ng and C. C. Mei, "The behavior of cold-formed steel anchor plate subjected to pure axial tension force," 4<sup>th</sup> *International Conference on Steel & Composite Structures*, Sydney, Australia, July 21-23, 2010.
- [5] Jabatan Kerja Raya Malaysia, Makluman spesifikasi terkini JKR: Prefabricated cold formed steel roof trusses, (JKR 20601-0186-11), Jabatan Kerja Raya Malaysia, Kuala Lumpur, Malaysia, 2012.
- [6] Australian Standard, *Metallic materials: tensile testing at ambient temperature*, (AS 1391: 2007), Standards Australia, 2007.