

Experimental Analysis and Optimization of Process Parameters in Plasma Arc Cutting Machine of EN-45A Material Using Taguchi and ANOVA Method

Sahil Sharma, Mukesh Gupta, Raj Kumar, N. S Bindra

Abstract—This paper presents an experimental investigation on the optimization and the effect of the cutting parameters on Material Removal Rate (MRR) in Plasma Arc Cutting (PAC) of EN-45A Material using Taguchi L_{16} orthogonal array method. Four process variables viz. cutting speed, current, stand-off-distance and plasma gas pressure have been considered for this experimental work. Analysis of variance (ANOVA) has been performed to get the percentage contribution of each process parameter for the response variable i.e. MRR. Based on ANOVA, it has been observed that the cutting speed, current and the plasma gas pressure are the major influencing factors that affect the response variable. Confirmation test based on optimal setting shows the better agreement with the predicted values.

Keywords—Analysis of variance, Material removal rate, plasma arc cutting, Taguchi method.

I. INTRODUCTION

PLASMA cutting is one of the thermal cutting processes, which uses the extremely constricted ionizing stream of gas, known as plasma jet, to cut any onerous material [1]. This is the special type of cutting process which can be used not only to cut hard and conductive materials but also to cut the non-conductive materials using transferred and non-transferred modes respectively. Plasma is the fourth state of matter after solid, liquid and gas, which exhibits some properties as that of gas but is actually different from the gas. Plasma is a good conductor of electricity and it also responds to the electromagnetic field [2]. Plasma cutting process is not a new process but still in order to achieve better quality results, we have to understand the mechanism and physics behind this process.

II. PRINCIPLE OF PLASMA CUTTING

Plasma cutting is basically a thermal cutting process in which constricted arc is used for the cutting operation. In this process, an inert gas like helium, argon or sometime compressed air is driven out from nozzle at a very high speed and at the same time, arc formed between anode (work piece) and cathode (electrode), turns the gas into plasma jet. Due to this, the gas dissociates into arc and thus becomes ionized. For

example, polyatomic gas dissociates into the arc and becomes partially ionized [3]. Thus, plasma beam generated by this way has a very high temperature and high kinetic energy. It melts and even partially vaporizes the material and blows it away from the surface of the material, thus produces the kerf as shown in Fig. 1. The temperature range in this process is near about 20,000 °C to 30,000 °C [4].

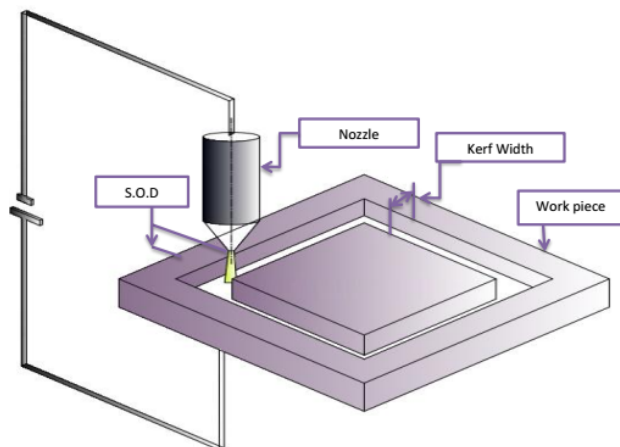

Fig. 1 Principle of PAC

III. LITERATURE SURVEY

Plasma cutting process is not a new process but the main challenge in the field of plasma is to increase the energy density so that hard materials can be cut by this process very easily and at a faster rate. For that, different researchers did a lot of work as given in Table I, not only to find out the various factors which affect the MRR and other cut quality variables but also to improve and optimize those cutting variables. From Table I, it is clear that cutting speed, current, stand-off-distance and plasma gas pressure are the most important process parameters which affect the quality cut characteristics in PAC process.

The objective of this paper is to find out the effect and optimization of various parameters like cutting speed, current, stand-off-distance (S.O.D) and plasma gas pressure on MRR in PAC of EN-45A material using Taguchi method. ANOVA is also used to find out the percentage contribution of each parameter on the response variable i.e. MRR.

Sahil Sharma is with the dept. of Mechanical Engineering, YMCA University of Science & Technology, Faridabad 121006 (e-mail: sahilvashist280@gmail.com)

TABLE I
KEY FINDINGS BY VARIOUS RESEARCHERS

Author	Key Findings
Bhuvnesh et al. [5] (2012)	The surface roughness (Ra) and MRR are inversely proportional to each other.
Das et al. [6] (2014)	Gas pressure is the most significant factor for the response variables i.e. MRR and S.R as compared to the arc current and torch height, when cutting EN 31 material with PAC process using GRA method.
Prajapati et al. [7]	Cutting speed and current are the most significant factors which affect the MRR, whereas plasma gas pressure and stand-off-distance are the minor influencing factors.
Prajapati et al. [8] (2015)	The MRR decreases with increase in cutting speed and gas pressure, whereas it increases with cutting current.
Singh and Akhai [9] (2015)	Cutting speed as compared to the other factors viz. kerf and stand-off-distance is the most influencing factor that affects the MRR. Higher the cutting speed more will be the MRR.
Das et al. [10] (2014)	The most influencing factor which affects the response variables i.e. MRR and S.R is the gas pressure followed by the cutting current using WPCA method.
Teja et al. [11] (2015)	Plate thickness and current are the important parameters which determine the Kerf width and surface roughness of component after cutting operation.
Maity and Bagal [12] (2014)	Torch height and feed rate are the main important parameters which determine the cut quality parameters such as Kerf width, chamfer, MRR and S.R.
Thilak et al. [13] (2016)	Current and gas pressure as compared to the speed and arc gap, are the parameters which determine the hardness, kerf width and machining time while cutting the 316L stainless steel material using PAC process.

TABLE II
CHEMICAL COMPOSITION OF EN-45A MATERIAL

Content	C	Si	Mn	S	P	Cr	W
Volume %	0.577	1.91	0.861	0.0494	0.0482	0.14	0.0150

TABLE III
MECHANICAL PROPERTIES OF MATERIAL

Material	EN-45A
Yield Tensile Strength	486.1 N/mm ²
Ultimate Tensile Strength	774.3 N/mm ²
Young Modulus, E	2.1 x 10 ⁵ N/mm ²
Poisson's Ratio	0.269
Hardness (HB)	274
Elongation	21.7 %
Density (ρ)	0.0000808 Kg/mm ³
Melting temperature	1430°C

IV. EXPERIMENTAL PROCEDURE

A. Base Material

For research, we selected a medium alloy carbon steel EN-45A material, which has a high degree of hardness, fatigue strength and compressive strength. It is extensively used in automobile sector especially in manufacturing of leaf spring, and also for machine building etc. The chemical composition of this material is given in Table II.

EN-45A material is known as Spring steel or Manganese-Silicon steel. The material EN-45A is widely used in the motor vehicle industry and has many other engineering applications. The typical application of the material EN-45A includes manufacturing of the conical springs, helical springs, spring plates and leaf spring. Mechanical properties of this material are given in Table III. This steel consists 1.91 silicon percentages which makes this material a very good scaling and

corrosion resistant as compared to the Mild steel. This steel has a high resistance, fatigue strength and toughness. It is hardened by the oil quenching process at 850-900 °C and then it is tempered at the 470-530 °C.

B. Experimental Set Up

The experiment has been performed on Hycut air Computer Numerical Control (CNC) plasma cutting machine. The compressed air has been used as the main cutting gas for the cutting operation. The fixed variables and their set values are given in Table IV. The square blocks of size 70 mm × 70 mm × 12 mm thickness have been cut from the plate in order to find out the MRR. The materials were allowed to cool at room temperature between the cuts.

TABLE IV
FIXED VARIABLES

Fixed Parameter	Set value
Material	EN-45A
Sample size	70 × 70
Thickness	12 mm
Nozzle diameter	10.5 mm (exit)
Plasma gas	Air

C. Design of Experiment

Design of experiment (DoE) is a technique of statistics which includes planning, conducting, analyzing and interpreting the experiments in order to understand the effect of various parameters on the process performance and also to determine the optimum variable values. For this experiment, Taguchi method was selected with four variables and each having four different levels as shown in Table V. MRR which is defined as the ratio of weight difference of the work piece before and after cutting operation to the product of density multiplied by the machining time (t_m) is expressed in cm³/s for this study. The weight difference is measured by the Precisa XT-1220 M electronic weighing machine having readability equals to 0.001gm.

TABLE V
LEVELS OF CUTTING PARAMETERS

Parameters	Level 1	Level 2	Level 3	Level 4
Cutting speed, (V)	280	300	320	340
Current, (I)	50	55	60	65
S.O.D, (S)	2	4	6	8
Gas Pressure, (P)	63	68	73	78

In Taguchi method, the orthogonal array develops the basis for the experimental analysis. The selection of orthogonal array (OA) is based on the total degree of freedom (DOF) of cutting process parameters. The DOF related with four parameters is equal to the 12 (Parameters*(no. of levels-1)). The OA is selected in such a manner that the DOF of OA should be greater than or equal to the DOF of process parameters. Therefore, L₁₆ OA having DOF equal to 15 has been selected for the present experiment. The layout of experiment and its corresponding result is given in Table VI.

TABLE VI
EXPERIMENTAL OBSERVED VALUES OF MRR AND S/N RATIOS

Exp. No.	V (mm/min)	I (ampere)	S (mm)	P (psi)	MRR (cm ³ /s)	S/N ratio
01	1	1	1	1	0.8701	-1.2086
02	1	2	2	2	0.8760	-1.1499
03	1	3	3	3	0.8940	-0.9732
04	1	4	4	4	0.9080	-0.8382
05	2	1	2	3	0.8830	-1.0807
06	2	2	1	4	0.9060	-0.8574
07	2	3	4	1	0.9110	-0.8096
08	2	4	3	2	0.8930	-0.9829
09	3	1	3	4	0.9150	-0.7716
10	3	2	4	3	0.9010	-0.9055
11	3	3	1	2	0.9070	-0.8479
12	3	4	2	1	0.9020	-0.8959
13	4	1	4	2	0.8990	-0.9248
14	4	2	3	1	0.9210	-0.7148
15	4	3	2	4	0.9370	-0.5652
16	4	4	1	3	0.9010	-0.9055
Average					0.9015	-0.902

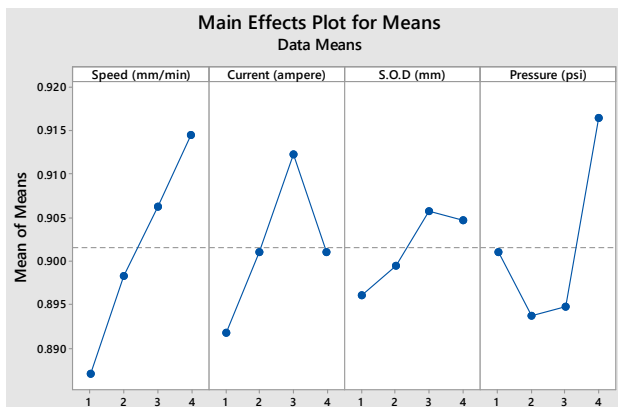

Fig. 2 Effect of various parameters on MRR

V. EFFECT OF CUTTING VARIABLES ON MRR

A. Effect of Cutting Speed

Cutting speed is one of the most important parameters in plasma cutting process, and it decides the quality of cut. From Fig. 2, it has been observed that MRR increases with the increase in cutting speed. Therefore, high cutting speed (within limits) is recommended for cutting operation in order to get the higher MRR. It must be noted that high speed should be within certain limits because if the cutting-speed will go beyond the limits, then there will be a problem of arc stability which will cause decrease in the MRR.

B. Effect of Current

Cutting current plays a significant role in cutting operation. Too low or too high current cause quality cut problems. From Fig. 2, it has been observed that the MRR first increases with increase in current and after attaining the maximum value it starts decreasing sharply from current 60 to 65 A. The reason for the decrease in MRR may be due to the fact that as the current increases beyond the limit there is a chance of

turbulence in the flow due to which arc cannot remain perpendicular, resulting in high cut quality problem (surface roughness) and we know that surface roughness and MRR are inversely proportional to each other [5], therefore, MRR is decreasing with increasing current from 60 to 65A.

C. Effect of S.O.D

S.O.D., also known as the arc gap, is defined as the distance between tip of nozzle and the work piece. The shape of arc is totally dependent upon the arc gap. Larger the arc gap more will be the deflection of the arc from the processing area and hence poor will be the quality cut. Fig. 2 shows the effect of arc gap on MRR. From this figure, it has been concluded that MRR increases with increase in S.O.D from 2 to 6 mm S.O.D, after that MRR starts to decrease from 6 to 8 mm S.O.D. The reason for this decreasing MRR is due to the fact that, as the arc gap increases beyond a limit, then the arc takes the shape of reversed candle flame than cylindrical shape [14], resulting in the poorer quality cut.

D. Effect of Plasma Gas Pressure

According to Jeffus [15], any gas or mixture of gases can be used for the plasma cutting. Plasma gas pressure also plays a very important role in cutting process. From Fig. 2, it has been concluded that MRR first decreases with increase in gas pressure from 63 to 68 psi but after 68 psi gas pressure the material removal rate starts increasing. It may be noted that there is a sharp increment in the MRR from the 73 to 78 psi. This may be occurring due to the fact that higher plasma gas pressure leads to increase in the mean arc voltage and its fluctuations, due to this more heat is transferred into the component [10], resulting in higher MRR.

VI. OPTIMIZATION OF PLASMA CUTTING PROCESS PARAMETERS

After finding out the effect of various parameters on MRR, next step is to find out the percentage contribution of each parameter and also to optimize the value of those parameters. ANOVA method has been used to find out the % contribution of each parameter. ANOVA table (Table VII) clearly reveals that cutting speed, current and plasma gas pressure are the most significant factors (P value < 0.05) and the % contributions of these parameters are also represented in Fig. 3.

TABLE VII
ANOVA FOR MRR

P. P	DOF	SS	MS	F	P	C (%)
V	3	0.001647	0.000549	29.01	0.010*	39.74
I	3	0.000843	0.000281	14.85	0.026*	20.28
S	3	0.000250	0.000083	4.41	0.127	6.23
P	3	0.001323	0.000441	23.32	0.014*	32.27
Residual Error	3	0.000057	0.000019			1.48
Total	15	0.004120				100

*Significant at 95% confidence

Note: P.P- process parameters, SS- sum of squares, MS- mean of squares, C (%) - contribution %

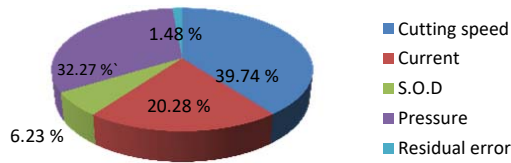

Fig. 3 % contribution of various parameters

The response table, Table VIII, provides the main effects on MRR. Fig. 4 shows the S/N ratio plots for the MRR. For this experiment, higher-the-better S/N ratio has been used. From the response table and S/N ratios, we can conclude the optimum parameter combination for MRR is $V_4 I_3 S_3 P_4$.

- Cutting speed = 340 mm/min.
- Current = 60 A
- S.O.D = 6 mm
- Gas pressure = 78 psi

TABLE VIII
RESPONSE TABLE FOR S/N RATIO

Level	Cutting speed	Current	S.O.D	Pressure
1	-1.0425	-0.9964	-0.9549	-0.9072
2	-0.9327	-0.9069	-0.9229	-0.9764
3	-0.8552	-0.7990	-0.8607	-0.9663
4	-0.7776	-0.9057	-0.8696	-0.7581
Delta	0.2649	0.1975	0.0942	0.2183
Rank	1	3	4	2

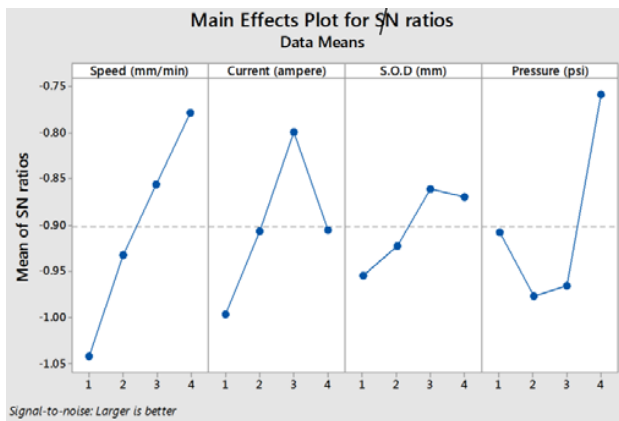

Fig. 4 Main effect plots for S/N ratios

VII. OPTIMAL VALUE OF MRR AND CONFORMANCE TEST

In order to predict the optimal value of the performance characteristics i.e. MRR, only significant parameters of the process are included which are found by the ANOVA method. The optimal values are found using (1) and (2):

$$\eta_p = \eta_a + \sum_{i=1}^n (\eta_i - \eta_a) \quad (1)$$

where: η_p is the optimum value of the S/N ratio; η_a is the total mean of multi response S/N ratio; η_i is the mean of multi response S/N ratio at the optimum value (from Table VIII), and n is the number of control factors that significantly affects the MRR. Table IX shows the value of η_a and η_i obtained from

Tables VI and VIII, respectively.

TABLE IX
VALUES OF MRR S/N RATIO

$(\eta)_a$	$(\eta)_v$	$(\eta)_i$	$(\eta)_s$	$(\eta)_p$
-0.902	-0.7776	-0.7990	-0.8607	-0.7581

The value of the MRR corresponding to

$$\eta_p = \sqrt[10]{\frac{1}{- \eta_p / 10}} \quad (2)$$

A. Confirmation Test

After the optimal level of process variables has been found out, a verification test needs to be conducted in order to check the accuracy of the analysis, done by ANOVA method. For the validation of this result, two confirmation experiments were performed at the optimum parameters settings for MRR. Table X summarizes the results obtained from the predicted value using (2) as well as the confirmatory experiments. Validation experiments confirmed the predicted value of MRR at 95 % confidence level.

TABLE X
COMPARISON BETWEEN PREDICTED AND CONFIRMATORY RESULTS

P.C	O.C.O.C.P	P.V	C.M.V.	% Error
M.R.R	$V_4 I_3 S_3 P_4$	0.9452 cm ² /s	0.9834 cm ² /s	4.04

Note: P.C- Performance characteristics, O.C.O.C.P- Optimum combination of cutting parameters, P.V- Predicted Value, C.M.V- Confirmatory Mean value.

VIII. CONCLUSIONS

The aim of this paper was to investigate the effect of machining parameters on MRR and to obtain the optimal conditions for maximizing the response variable, i.e. MRR in PAC of EN45A steel using Taguchi OA with ANOVA method. The optimal combination of the cutting process parameters is obtained as $V_4 I_3 S_3 P_4$ (highest level of cutting speed and gas pressure and middle level of current and S.O.D). Based on ANOVA, the most effective parameters in descending order are: Cutting speed, gas pressure, current and S.O.D. The S.O.D is the least effective factor within a specified test range. To check the validity of the analysis, two confirmation tests have been carried out. The comparison between predicted value and the confirmation test result value shows an improvement of 4.04% in the MRR, which indicates that the experiments in this study possess excellent repetitiveness and has a great potential for the future references.

REFERENCES

- [1] Bidajwala R. C., Trivedi M. A., Rao T. S., Gajera H. M., "Parametric optimization on Plasma arc cutting machine for AISI 1018", International Journal of Advance Engineering and Research Development, 2348-4470, 2015.
- [2] [http://www.boegas.co.nz/facts about plasma technology](http://www.boegas.co.nz/facts%20about%20plasma%20technology), 20/10/2016
- [3] Dubbel (1994) "Handbook of mechanical engineering", springer verlag London limited, Inc;17-18, 1994.
- [4] ChamarthiS., Reddy N. S., Elipey M. K., Reddy D.V. R., "Investigation

- Analysis of Plasma arc cutting Parameters on the Unevenness surface of Hardox-400 material*", International Conference on design and manufacturing, 854 – 861, 2013.
- [5] Bhuvanesh R., Norizaman M.H., Manan M.S. A., "Surface Roughness and MRR Effect on Manual Plasma Arc Cutting Machining", International Journal of Mechanical, Aerospace, Industrial, Mechatronic and Manufacturing Engineering, Volume 6, No:2, 2012.
- [6] Das M. K., Kumar K., Barman T. K., Sahoo P., "Optimization of process parameters in Plasma arc cutting of EN 31 steel based on MRR and Multiple roughness characteristics using Grey Relational analysis", International Conference on Advances in Manufacturing Engineering (AMME), 1550-1559, 2014.
- [7] <http://mechanical.srpec.org.in/files/Project/2013/17.pdf>, 22/10/2016
- [8] Prajapati K. N., Sathavara H.R., Soni D.K., "A review on plasma arc cutting", International Journal of Advance Research in Engineering, Science & Technology (IJAREST), Volume 2, Issue 6, 2015.
- [9] Singh G. and Akhai S., "Experimental study and Optimization of MRR in CNC Plasma arc cutting", International Journal of Engineering Research and Applications, Volume 5, Issue 6, pp. 96-99, 2015.
- [10] Das M. K., Kumar K., Barman T. K., Sahoo P., "Optimization of MRR and surface roughness in PAC of EN 31 steel using weighted principle component analysis", 2nd International Conference on Innovation in Automation and Mechatronics Engineering (ICIAME 2014), 211-218, 2014.
- [11] Teja S. S., Karthik G., Sampath S., Shaj M., "Experimental Investigations to Study the Impact of Machining Parameters on Mild Steel Using Plasma Arc Cutting", International Journal of Engineering Research and Applications, Volume 5, Issue, ISSN: 2248-9622, 2015.
- [12] Maity K. P., Bagal D. K., "Effect of process parameters on cut quality of stainless steel of plasma arc cutting using hybrid approach", International Journal of Advance Manufacturing Technology, 161-175, 2014.
- [13] Thilak. M, Cyril G., Boopalan N., Gogul. N, Ganesh B. A.R., "Optimization of Machining Process Parameters in Plasma Arc Machining", International Journal of Innovative Research in Science, Engineering and Technology, Volume 5, Special Issue 8, ISSN(Online) : 2319-875, 2016.
- [14] Salonitis K. and Vatousianos S., "Experimental Investigation of the sssPlasma Arc Cutting Process", 45th CIRP Conference on Manufacturing Systems 2012, 287-292, 2012.
- [15] Jeffus Larry, "Welding Principles and Applications: Sixth Edition:", Inc; p. 182-203, 2003.