

Exergy Analysis of a Solar Humidification-Dehumidification Desalination Unit

Mohammed A. Elhaj and Jamal S. Yassin

Abstract—This paper presents the exergy analysis of a desalination unit using humidification-dehumidification process. Here, this unit is considered as a thermal system with three main components, which are the heating unit by using a solar collector, the evaporator or the humidifier, and the condenser or the dehumidifier. In these components the exergy is a measure of the quality or grade of energy and it can be destroyed in them. According to the second law of thermodynamics this destroyed part is due to irreversibilities which must be determined to obtain the exergetic efficiency of the system.

In the current paper a computer program has been developed using visual basic to determine the exergy destruction and the exergetic efficiencies of the components of the desalination unit at variable operation conditions such as feed water temperature, outlet air temperature, air to feed water mass ratio and salinity, in addition to cooling water mass flow rate and inlet temperature, as well as quantity of solar irradiance.

The results obtained indicate that the exergy efficiency of the humidifier increases by increasing the mass ratio and decreasing the outlet air temperature. In the other hand the exergy efficiency of the condenser increases with the increase of this ratio and also with the increase of the outlet air temperature.

Keywords—Exergy analysis, desalination, solar, humidifier, condenser.

I. INTRODUCTION

DUE to insisting need for desalination as an alternative for fresh water crisis at the mean time and in future, and due to privileged technical and thermal characteristics of the humidification dehumidification process compared with other techniques, and due to the promised role of the solar energy as a renewable source, this study has been to simulate, model and optimize the solar HD desalination technique. The importance of this method comes out due to the following advantages [1]:

- Low specific process heat consumption of 100-140 kWh thermal per meter cube of fresh water.
- Low temperature process heat can be supplied by solar collectors, waste heat or other sources of low temperature heat, (e.g. geothermal).
- Raw water of any salinity can be used (brackish, sea, even brine of other processes).
- No chemical pre-treatment needed.

Mohammed A. Elhaj is Dean of the Faculty of Engineering, University of Misurata, Misurata, Libya (phone: +218-913105704; e-mail: elhaj1965@yahoo.com).

Jamal S. Yassin is with the Mechanical Engineering Department, University of Misurata, Misurata, Libya (e-mail: jsyassin59@yahoo.com).

- Low auxiliary energy demand (pumps) can be provided by PV cells.
- Product water is distillate (best quality product water).
- Modular set up - Capacities of up to 5m³ per day are considerable.
- Simple and robust construction, easy maintenance.
- No corrosion because all components in contact with brine are made of plastic materials.

In the current study a mathematical model for the solar HD desalination process has been developed for the all components of the system, which is composed of two main units, the heating unit and the distillation unit. From this model the performance parameters are specified which include the operational, design and environmental conditions. The operational parameters include the inlet and outlet temperatures of the feeding water, air stream, and cooling water, while design parameters include the size of the evaporator and condenser as well as the type and size of the solar collector, which could be flat plate or parabolic trough. The environmental parameters include the solar insolation, the ambient temperature and pressure, and the wind speed in the certain zone.

II. CONCEPT OF EXERGY

The first law of thermodynamics introduces the concept of energy conservation, which states that energy entering a thermal system with fuel, electricity, flowing streams of matter, and so on is conserved and cannot be destroyed. In general, energy balances provide no information on the quality or grades of energy crossing the thermal system boundary and no information about internal losses. By contrast, the second law of thermodynamics introduces the useful concept of exergy in the analysis of thermal systems.

Exergy is a measure of the quality or grade of energy and it can be destroyed in the thermal system. The second law states that part of the exergy entering a thermal system with fuel, electricity, flowing streams of matter, and so on is destroyed within the system due to irreversibilities. The second law of thermodynamics uses an exergy balance for the analysis and the design of thermal systems [2].

Exergy not only can be destroyed by irreversibilities but also can be transferred to a system or from a system, as in losses accompanying heat transfers to the surroundings. Improved resource utilization can be realized by reducing exergy destruction within a system and/or losses. An objective in exergy analysis is to identify sites where exergy destructions and losses occur and rank order them for

significance. This allows attention to be centered on the aspects of system operation that offer the greatest opportunities for improvement [3].

The exergy rate balance for a control volume can be written in the following general form:

$$\frac{dE_{cv}}{dt} = \sum_j \left(1 - \frac{T_o}{T_j}\right) \dot{Q}_j - \left(\dot{W}_{cv} - P_o \frac{dV_{cv}}{dt}\right) + \sum_i \dot{m}_i e_{fi} - \sum_e \dot{m}_e e_{fe} - \dot{E}_d \quad (1)$$

The first term in this equation represents the time rate of change of the exergy of the control volume. The term \dot{Q}_j represents the time rate of heat transfer at the location on the boundary where the instantaneous temperature is T_j . The accompanying exergy transfer rate is given by $(1 - T_o/T_j)\dot{Q}_j$. The term \dot{W}_{cv} represents the time rate of energy transfer rate by work other than flow work. The accompanying exergy transfer rate is given by $(\dot{W}_{cv} - P_o dV_{cv}/dt)$, where dV_{cv}/dt is the time rate of change of volume. The term $\dot{m}_i e_{fi}$ accounts for the time rate of exergy transfer accompanying mass flow and flow work at inlet. Similarly, $\dot{m}_e e_{fe}$ accounts for the time rate of exergy transfer accompanying mass flow and flow work at exit. Finally, the term \dot{E}_d accounts for the time rate of exergy destruction due to irreversibilities within the control volume.

For steady state and adiabatic process without work as in the humidifier or dehumidifier, the last equation can be reduced as following:

$$\dot{E}_d = \sum_i \dot{m}_i e_{fi} - \sum_e \dot{m}_e e_{fe} \quad (2)$$

The flow exergies appearing in this equation can be determined from the following equation, each at its location, after neglecting the values of kinetic and potential energies because they are very small, thus

$$e = (h - h_o) - T_o (s - s_o) \quad (3)$$

III. EXERGY ANALYSIS OF THE HUMIDIFIER

According to (2) the exergy destruction of the humidifier can be written as following, using the nominations in Fig. 1.

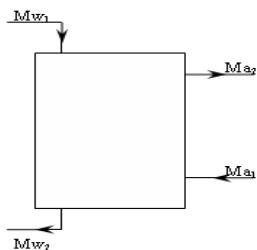

Fig. 1 Working fluids directions in the humidifier

$$\dot{E}_{d,h} = \dot{m}_{w1} e_{w1} + \dot{m}_{a1} e_{a1} - \dot{m}_{w2} e_{w2} - \dot{m}_{a2} e_{a2} \quad (4)$$

where

$$\dot{m}_{a2} = \dot{m}_a (1 + w_1) + \dot{m}_{fw} \quad (5)$$

$$\dot{m}_{w2} = \dot{m}_{w1} - \dot{m}_{fw} \quad (6)$$

IV. EXERGY ANALYSIS OF THE CONDENSER

The exergy destruction of the condenser, from Fig. 2 can be written as following:

$$\dot{E}_{d,c} = \dot{m}_{a2} e_{a2} + \dot{m}_{cw} e_{cw,i} - \dot{m}_{a1} e_{a1} - \dot{m}_{cw} e_{cw,o} - \dot{m}_{fw} e_{fw} \quad (7)$$

The exergy of fresh water given in this equation can be determined from the following [4]:

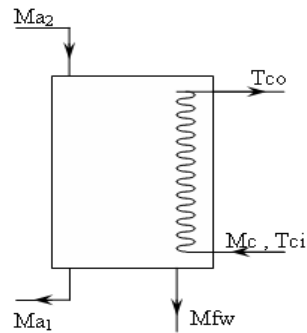

Fig. 2 Working fluids directions in the condenser

$$e_{fw}(T) = h_f(T) - h_g(T_o) - T_o s_f(T) + T_o s_g(T_o) + [P - P_{sat}(T)] v_f(T) - R_v T_o \ln \phi_o \quad (8)$$

when the liquid water stream is in thermal equilibrium with the ambient, $T=T_o$ [recall the relation $h_{fg}(T) = T s_{fg}(T)$], the first four terms add up to zero. In the remaining terms, the first one is very small compared with the second, so it can be neglected, keeping the last term, thus

$$e_{fw} = -R_v T_o \ln \phi_o \quad (9)$$

where ϕ_o is the relative humidity of saturated air at the standard temperature T_o , and is equal to 0.6.

V. EXERGETIC EFFICIENCY

Three definitions of exergetic efficiencies for steady state processes are found in the literature. These are the conventional or simple exergetic efficiency, the rational exergetic efficiency and the utilizable exergy coefficient [5].

The conventional definition is the ratio of the total outgoing exergy flow to the total incoming exergy flow, thus

$$\eta = \frac{\dot{E}_{out}}{\dot{E}_{in}} \tag{10}$$

The rational exergetic efficiency is defined by Kotas as a ratio of the desired exergy output to the exergy used or consumed.

$$\eta = \frac{\dot{E}_{desired,output}}{\dot{E}_{used}} = 1 - \frac{\dot{E}_d}{\dot{E}_{used}} \tag{11}$$

$\dot{E}_{desired,output}$ is the sum of all exergy transfers from the system, which must be regarded as constituting the desired output, plus any by-product, which is produced by the system. The desired output is determined by examining the function of the system. \dot{E}_{used} is the required exergy consumed for the process to be performed.

The rational efficiency can be applied to any system, except to purely dissipative systems, because no desired product can be defined in this case.

The utilizable exergy coefficient has been introduced by Brodyansky et al., and it is an improvement on the traditional exergetic efficiency, because it subtracts the untransformed components from the incoming and outgoing streams.

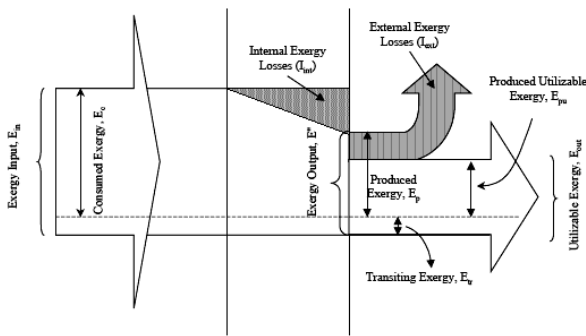

Fig. 3 Graphical presentation of overall exergy balance

According to the graphical presentation of overall exergy balance shown in Fig. 3, this coefficient is given by

$$\eta = \frac{\dot{E}_{out} - \dot{E}_{tr}}{\dot{E}_{in} - \dot{E}_{tr}} = \frac{\dot{E}_{pu}}{\dot{E}_c} \tag{12}$$

where \dot{E}_{tr} is the transiting exergy rate, \dot{E}_{pu} is the produced utilizable exergy rate and \dot{E}_c is the consumed exergy rate.

According to the second definition, which is more appropriate in the current study, the exergetic efficiencies of the humidifier and condenser can be expressed as follows:

$$\eta_{e,h} = 1 - \frac{\dot{E}_{d,h}}{\dot{m}_{w1}e_{w1} - \dot{m}_{w2}e_{w2}} \tag{13}$$

$$\eta_{e,c} = 1 - \frac{\dot{E}_{d,c}}{\dot{m}_{a2}e_{a2} - \dot{m}_{a1}e_{a1}} \tag{14}$$

VI. RESULTS AND DISCUSSION

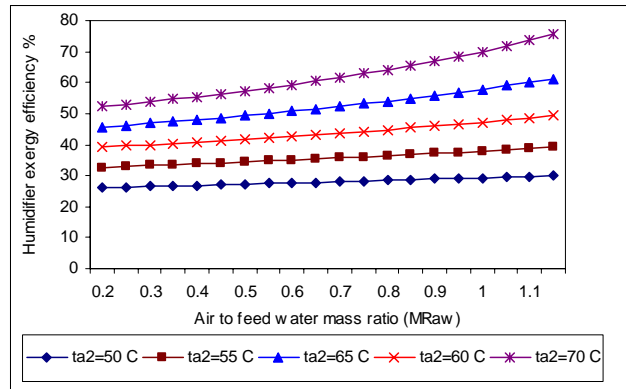

Fig. 4 Humidifier exergy efficiency versus mass ratio and air temperature

The humidifier exergy efficiency is calculated here as a ratio of the desired exergy output to the input exergy. The output exergy is related with the exergy destruction, in which it is the difference between the input exergy and the destruction. According to this definition, it is shown in Fig. 4, that there is no noticeable change in the value of the humidifier exergy efficiency with the air to feed water mass ratio at low air temperature, while at higher temperatures, more than 60°C, this efficiency increases. Also at a certain mass ratio we notice that this efficiency increases with the temperature. This is due to the decrease in exergy destruction at higher temperatures as well as higher mass ratio.

The condenser exergy destruction and efficiency are inversely proportional, here we notice as the mass ratio and the air exit temperature goes up, the loss of energy to the ambient increases, this means more exergy destruction, as shown in Fig. 5, consequently the condenser exergetic efficiency goes down, as shown in Fig. 6.

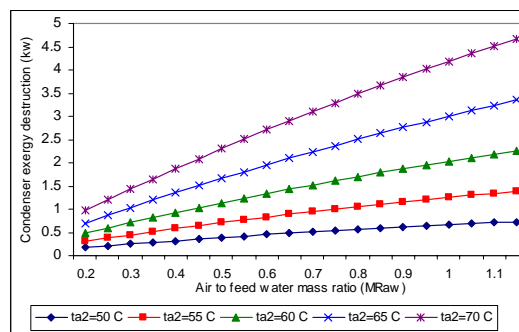

Fig. 5 Condenser exergy destruction versus mass ratio and air exit temperature

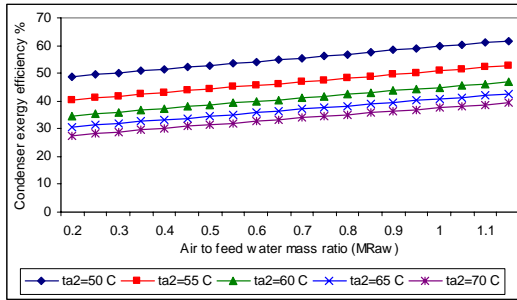

Fig. 6 Condenser exergetic efficiency versus mass ratio and air exit temperature

While the amount of feed water does not influence on the humidifier exergy efficiency, is shown in Fig. 7. This is because by increasing the amount of feed water at a certain mass ratio the amount of air increases by the same percentage, and since these two parameters are ratios, so they are independent of feed water rate at constant value of mass ratio.

Although the exergy destruction increases with the feed water rate, as shown in Fig. 8, there is no increase of the humidifier exergy efficiency; this is because by increasing the feed water rate the input exergy of the humidifier increases too by the same percentage, keeping the efficiency independent of this variable.

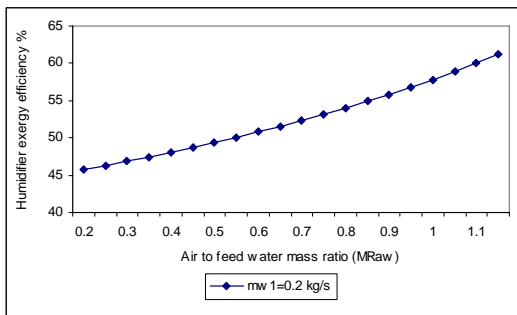

Fig. 7 Humidifier exergy efficiency versus mass ratio and feed water rate

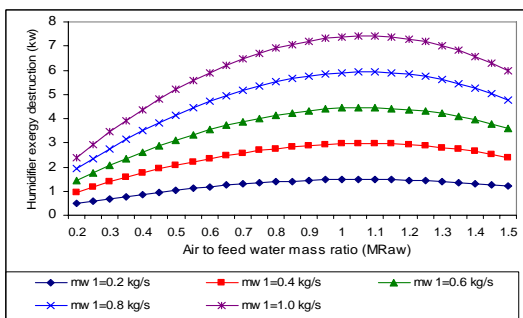

Fig. 8 Humidifier exergy destruction versus mass ratio and feed water rate

By increasing the outlet temperature of the cooling water due to the increase of cooling water rate, the exergy

destruction of the condenser to the atmosphere increases as shown in Fig. 9, consequently the condenser exergetic efficiency decreases at a certain mass ratio as shown in Fig. 10.

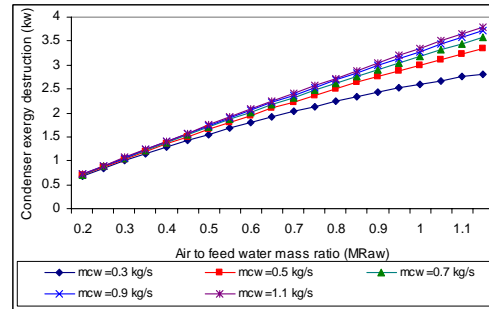

Fig. 9 Condenser exergy destruction versus mass ratio and cooling water rate

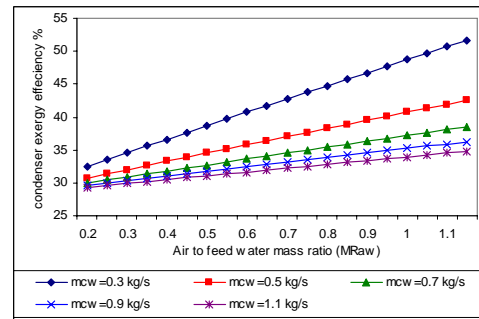

Fig. 10 Condenser exergy efficiency versus mass ratio and cooling water rate

For a certain length of the humidifier and fixed values of air inlet and outlet temperatures, as the feeding water temperature increases there is no improvement in the fresh water productivity or recovery ratio, and the influence appears on the exergy destruction, and consequently on the humidifier exergetic efficiency. In which the exergy destruction increases with the feeding water and then the exergetic efficiency decreases as shown in Figs. 11 & 12, respectively.

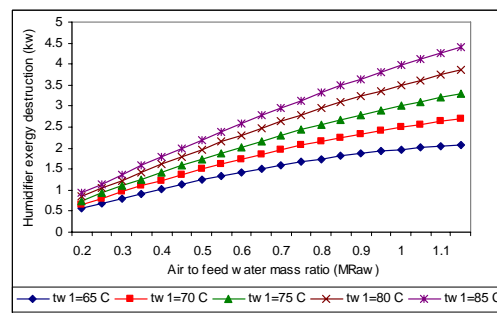

Fig. 11 Humidifier exergy destruction versus mass ratio and feed water temperature

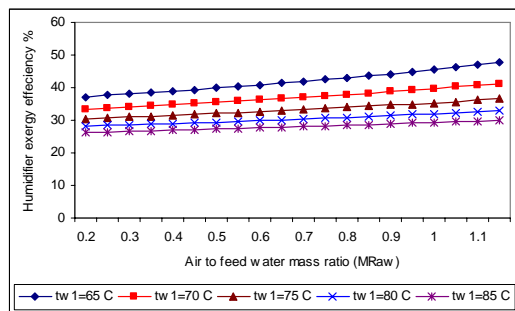

Fig. 12 Humidifier exergy efficiency versus mass ratio and feed water temperature

VI. CONCLUSIONS

A numerical study was carried out to investigate the exergy analysis and performance prediction of solar desalination by using humidification-dehumidification process. The desalination system consists of a solar heater unit. This last unit has cylindrical shape and composed of the humidifier, which is inside the unit, and surrounded by the condenser or the dehumidifier.

The operational parameters which are carried out here are those who show the most crucial rules in governing the performance of the desalination unit, such as feed water to air mass ratios, temperatures, cooling water mass rates and salinity of feed water.

Due to variety of input parameters that could influence on the general performance of the desalination unit a computer software has been developed in this case with many pages to analyze and model the desalination system. From the outputs obtained at these input variables we deduce the following:

1. The air to feed water mass ratio has shown a great influence on the performance of the desalination unit. Here, the exergy efficiency of both humidifier and dehumidifier getting improved by increasing this ratio.
2. The air exit temperature influences on the exergy destruction which goes up by this parameter in the condenser, consequently the condenser exergy efficiency goes down.
3. The other important parameter which has shown influence on the exergy is the feed water mass flow rate. Here, at a certain mass ratio by increasing the feed water mass rate the air mass rate increases too, giving higher humidifier exergy.
4. The influence of feed water inlet temperature has been studied from thermodynamic point of view and from optimization point of view. In the first case it has been taken with variable air to feed water mass ratio, and from 65 to 85°C, while in the second case it is taken as variable with different values of feed water mass flow rate. In both cases there as noticeable influence of this parameter. Here, the humidifier exergy efficiency goes up with the increase of this temperature.
5. The mass flow rate of the cooling water plays an important role in heat transfer within the condenser, in

which it absorbs the latent heat of the vapor, and at the same time gets preheated. Here, we notice by increasing the value the condenser exergy destruction increases, consequently the condenser exergy efficiency decreases.

6. One of the advantages of the HD units that it could be used with low heat energy source, and since this study is carried out by considering solar energy source only, another study could be done by taking the waste heat of an industrial firm in the analysis, to make a comparison between the two sources.

REFERENCES

- [1] H. Muller-Holst & W. Scholkepf, "Multi effect humidification seawater desalination using solar energy or waste heat- various implementation of a new technology", Bavarian Center for applied Energy Research, Munchen, Germany/324-STOH10.
- [2] F. A. Van Vught, Thermodynamics and Sustainable development, The use of exergy analysis and the reduction of irreversibility, R. L. Cornelissen, 1997, The Netherlands.
- [3] Michael J. Moran & Howard N. Shapiro, Fundamentals of Engineering Thermodynamics, John Wily & Sons, Inc., USA, 2004.
- [4] Adrian Bejan, Advanced Engineering Thermodynamics, John Wily & Sons, Inc., Singapore, 1988.
- [5] Masanori Shukuya & Abdelaziz Hammache, Introduction to the Concept of Exergy- for a better understanding of Low-Temperature-Heating & High- Temperature-Cooling Systems, VTT Technical Research Center of Finland, Finland, 2002.