

Enhancing capabilities of Texture Extraction for Color Image Retrieval

Pranam Janney, Sridhar G, Sridhar V.

Abstract—Content-Based Image Retrieval has been a major area of research in recent years. Efficient image retrieval with high precision would require an approach which combines usage of both the color and texture features of the image. In this paper we propose a method for enhancing the capabilities of texture based feature extraction and further demonstrate the use of these enhanced texture features in Texture-Based Color Image Retrieval.

Keywords—Image retrieval, texture feature extraction, color extraction

I. INTRODUCTION

ADVENT of internet has created a information super highway through which a vast amount of data is available to the end user. Exponential development in the field of image acquisition (e.g. digital cameras, etc) has made way for creation of digital libraries and multimedia databases, thus efficient search algorithms are need of the hour.

Image retrieval was previously based on annotating images using keywords describing the image which could then be searched using keywords. It was also difficult to annotate the rich content of an image using set keywords. This technique was time consuming and it limits the search criteria to a limited keywords. It is practically impossible to annotate images from a huge digital multimedia library. Moreover an uninformed user would find it difficult to provide the exact keywords as query to the database. This led to the realization, that image retrieval based on the image content was the more efficient. Thus Content-Based Image Retrieval databases based (CBIR) was developed. The Content-Based Image Retrieval [1] is aimed at efficient retrieval of relevant images from large

on automatically derived image features. Image features are the visual contents of an image such as color, shape, texture and spatial layout. In a typical CBIR the features of the images in the database are extracted and indexed accordingly. The image features of the query image are also extracted; the system determines the similarity/distances between the query image features and features from the database. Based on the best similarity/distance relevant images are retrieved from the database.

Query by Image Content (QBIC) system [2] allowed the user to select the relative importance of color, texture, and shape. The Virage system [3] allowed queries to be built by combining color, composition, texture, and structure. PATSEEK [12] based their design on Edge Orientation and Autocorrelogram (EOAC) [13] and Canny Edge detector [10]. Moments [4], Fourier descriptors [5, 6], chain codes [7, 8], edge direction histogram (EDH) using the Canny edge operator [9], [10] and Wavelets [11] have been used previously to describe image features. Gabor features have been experimentally shown to be most accurate to derive image feature vectors. Kingsbury [14], has used dual tree complex wavelet transforms to derive Gabor like features and has also shown that his complex wavelets are computationally more fast and efficient when compared to Gabor. All the above techniques are used to extract features relating to texture/shape features of an image. In order to extract color features, researchers have used color histograms and color distributions [15].

In this paper we have enhanced the capabilities of a texture feature extraction process to retrieve color images from image database.

II. IMAGE RETRIEVAL

There are numerous image retrieval algorithms [2, 3, 11] which use texture/shape extraction to retrieve images from database. These techniques work basically on grayscale images. Thus to retrieve color images researchers have used a color extraction process in addition to one of the texture/shape extraction process [15]. Texture extraction process could be used to retrieve color images [16]. However the problem arises from the fact that while using texture extraction process the system would not have any idea about the color composition of

Manuscript received March 31, 2005.

Pranam J. is with the Applied Research Group, Satyam Computer Services Limited, SID Block, Indian Institute of Science(IISc), Bangalore, India -560 012. (e-mail: Pranam_Janney@satyam.com).

Sridhar G. is with the Applied Research Group, Satyam Computer Services Limited, SID Block, Indian Institute of Science(IISc), Bangalore, India -560 012. (phone: +91-80-22231696; fax: +91- 80 -2227 1882; e-mail: Sridhar_Gangadharpalli@satyam.com).

Sridhar V. is with the Applied Research Group, Satyam Computer Services Limited, SID Block, Indian Institute of Science(IISc), Bangalore, India -560 012. (e-mail: Sridhar@satyam.com).

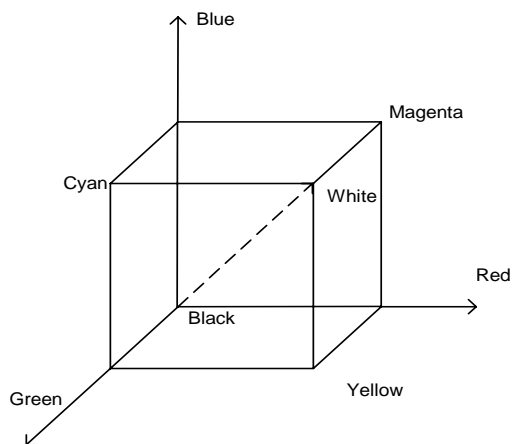

Fig.1 RGB space

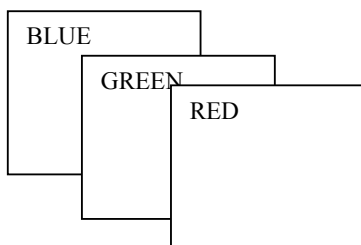

Fig.2 Three layers of a color image

the image. Using a texture extraction process alone to retrieve color images, would result in badly ranked recalls (e.g. best match for the query in terms of color composition may be placed as the lowest ranked image). The main purpose of image retrieval is to retrieve a set of images matching the query and the best match always should be ranked highest otherwise it defeats the whole purpose of image retrieval.

As seen from Fig. 2, color image consists of three layers i.e. Red, Green and Blue (RGB). The color composition could be represented in a RGB space, Fig. 1. The diagonal running through the space is the grayscale area. From the RGB space we can see that any color is a combination of red, green and blue elements. A basic color image could be described as three layered image with each layer as red, green and blue. When we consider a particular area of a color image, it could have different color combinations with respect to other areas of the image. An area with yellow would have a combination of red and green color elements only. Similarly an area with magenta would have combination of red and blue elements only. Thus if you consider an image of an object with yellow color, then the object is best described in red and green layers, not in blue layer. Hence, certain features are unique and distinct to each color layer for a particular image, depending on the color composition. We have harnessed on this theory to enhance the

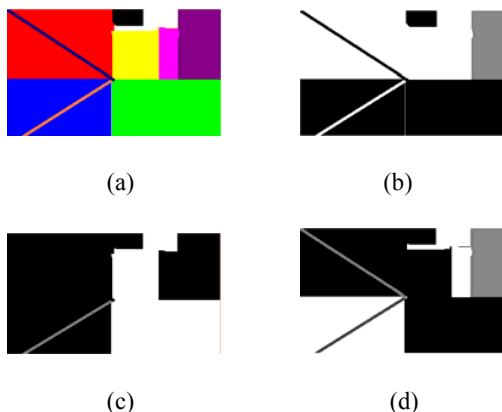

Fig.3 (a) Color Image; Different layers of the color image: (a) Red layer, (b) Green layer, (c) Blue layer images. (This figure should be preferably viewed in color print)

capabilities of a texture extraction process to retrieve color

Main objective of a texture/shape extraction process is to extract the prominent feature of an image. Thus if a query image has prominent features only in red layer and green layer, we could conclude that the image is some sort of combination of red and green elements, not blue. To get a better understanding of the process let us consider a color image as shown in Fig. 3. We can see that certain texture/shape features which appear in the red layer does not appear with the same intensity in the green or blue layers and vice versa is also true. Therefore by extracting feature vectors from each layer separately and matching the same with the database feature vectors we would get the best match features in red layer, green layer and blue layer respectively. Hence, if the feature vectors of each layer of the query have matched with feature vectors of each layer of a particular image in the database; we could conclude that the query image has a similar RGB structure compared the image from database or in other words suggesting that the query image color composition has matched with a color composition of an image in database. This would provide us with better ranking and effective retrieval of color images.

III. PROCEDURE

Recently developed complex wavelet transform (CWT) by Kingsbury [14] has been most efficient and fast in deriving Gabor like features from an image. In [16], it has been shown that CWT is efficient and computationally faster in retrieving texture images than any of the contemporary works. We have used CWT to transform the image into wavelet coefficients. We measure the mean and standard deviation of the magnitude of the transformed coefficients in each scale, each sub band to derive the feature vectors [16]. To calculate the distance between feature vectors we have used a newly developed Bayesian distance metric [16]. Bayesian distance metric has better performance characteristics than Euclidean distances [16].

We feed each layer of the RGB image separately to texture

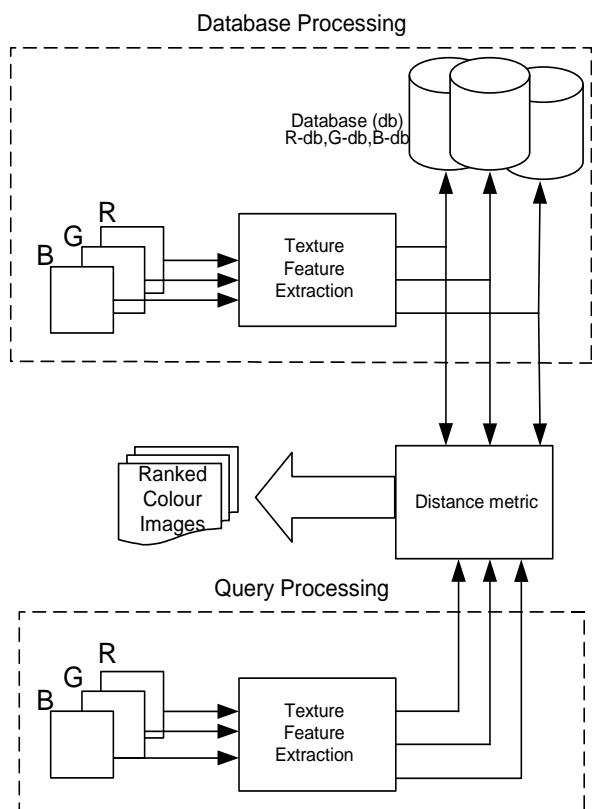

Fig.4 Overview of the entire system

extraction process and store the feature vectors corresponding to each layer in the feature vector database. We perform the same process on the query image and then calculate the distance metric for each respective feature vectors from respective layers. Based on each layer we get three different rankings, a simple average is calculated to derive the final ranking for the retrieved images. An overview of the entire system is shown in Fig. 4.

IV. TESTS AND RESULTS

Columbia University Image Library (COIL-100) [17] was used for our tests. The database was created using 100 objects photographed at 72 different angles. In total the database consists of 7200 images. We also used another database consisting of 1000 images with each image consisting of numerous objects. The images were mainly natural scenes, natural scenes with animals, beaches, beaches with boats, beaches with people, single and a group of African tribal, Medieval ruins, animals from Jurassic era, colorful salads, flowers etc.

Tests were performed with different types of queries:

- Grayscale query image consisting of single object
- Grayscale query image consisting of multiple objects
- Color query image consisting of single objects
- Color query image consisting of multiple objects

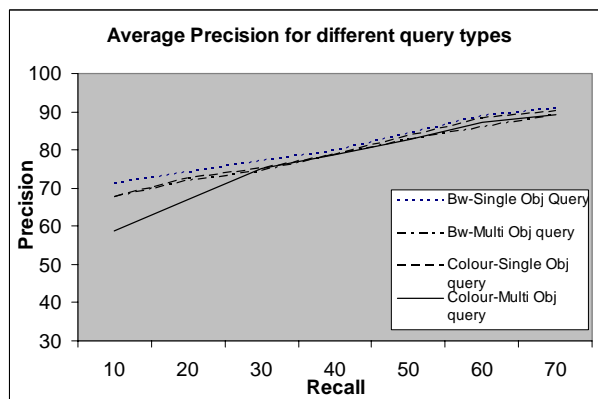

(a)

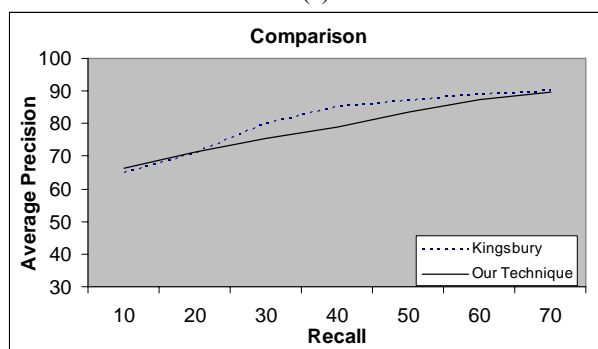

(b)

Fig.5 Tests results; (a) System performance for different types of queries, (b) Overall system performance in comparison with [16].

Recall and precision was used as performance evaluators for these tests. Precision was based on the type of image. For grayscale image query, precision depended upon retrieval of images consisting of single/multiple object(s) similar to single/multiple object(s) present in query image irrespective of color. For color image query, precision depended upon retrieval of images consisting of single/multiple object(s) similar to single/multiple object(s) in query image with color as another important criterion. We have also obtained results using Kingsbury [16] on grayscale images. Quantative performance results are shown in Fig. 5(a) and (b). From fig 5(b), the performance of our system to retrieve color images is as good as [16] to retrieve grayscale images. We have been able to enhance the capability of texture extraction process of [16] to retrieve color images effectively.

The ranking of the images was seen to improve. Different types of queries and first ten images retrieved are provided in the Appendix to gauge the qualitative performance. Color image query would retrieve relevant images in color itself. But a grayscale query would retrieve relevant grayscale images along with relevant color images.

We segmented the input image into smaller images and then performed the feature extraction process. We intended to arrive at a better ranking since we would have more feature

vectors per image. But the experimental results did not support this theory.

V. CONCLUSIONS AND FUTURE WORK

We have been successful in enhancing the scope of a texture extraction process to retrieve color images independently. In the future we hope to concentrate on optimizing the number of feature vectors to attain high precision.

APPENDIX

This section should be preferably viewed in color print. In Fig. 6,7,8 and 9; top-most image (first row) is the query image and the rest are retrieved images; the first ranked retrieved image is the leftmost (second row); Fig. 6 has tenth ranked is the rightmost (third row).



Fig.6 Query image is colored and consists of single object



Fig.7 Query image is grayscale consisting of single object



Fig.8 Query image is colored consisting of multiple objects



Fig.9 Query image is grayscale consisting of multiple objects

REFERENCES

- [1] Kato, T., "Database architecture for content based image retrieval in Image storage and Retrieval Systems" (Jambardino A and Niblack W eds), *Proc SPIE* 2185, pp 112-123, 1992.
- [2] Flickner, M. et al., "Query by Image and Video content: the QBIC system", *IEEE Computer*, vol 28, pp23-32, 1995.
- [3] Bach, J.R., et al., "The virage image search engine: an open framework for image management", *Proc. SPIE: Storage and retrieval for Still Image and Video Databases IV*, vol 2670, pp 76-87, 1996.
- [4] Hu, M.K., "Visual pattern recognition by moments invariants", *IRE Transactions on Information Theory*, IT-8, pp. 179-187, 1962.
- [5] Gonzalez R.C. and Wintps P., *Digital Image Processing*, Addison-Wesley Reading, MA, 1992.
- [6] Person, E. and Fu, K. S., "Shape discrimination using Fourier descriptors", *IEEE Transactions on Pattern Analysis and Machine Intelligence*, vol 8, pp 388-397, 1986
- [7] Freeman, H., "On the encoding of arbitrary geometric configurations", *IRE Trans. On Electronic Computers*, vol EC-10, pp 260-268, 1961
- [8] Zhang, D. and Lu, G., "Review of shape representation and description techniques", *Pattern Recognition*, 37(1), pp 1-19, 2004
- [9] Jain, A.K. and Vailaya, A., "Image Retrieval using Color and Shape", *Pattern Recognition*, vol 36, pp 1233 - 1244, August 1996.
- [10] Canny, J., "Computational approach to edge detection", *IEEE trans. Pattern Analysis and Machine Intelligence*, PAMI -8, pp 679-698, 1986.
- [11] Charles, E. J. et al. "Fast Multiresolution Image Querying", *Appeared in Proc SIGGRAPH*, August 1995
- [12] Avinash, T. et al., "PATSEEK: Content Based Image Retrieval System for Patent Database", *International Conference on Electronic Business*, 2004.
- [13] Mahmoudi, F. et al., "Image Retrieval based on shape similarity by edge orientation autocorrelogram", *Pattern recognition*, vol 36, pp1725-1736, 2003.
- [14] Kingsbury, N.G., "The Dual Tree Complex Wavelet Transform: a new efficient tool for image restoration and enhancement", *Proc. European Signal Processing Conf.*, pp319-322, Spetempber 1998.
- [15] Tian, Q. et al., "Content-Based Image Retrieval Using Wavelet-based Salient Points", *Appeared in Proc. SPIE Storage and Retrieval for Media Databases*, January 2001.
- [16] Peter, R. and Kingsbury, N., "Complex Wavelets Features for Fast Texture Image retrieval", *Proc IEEE Int. Conf. on Image Processing*, Kobe, Oct 25-28, 1999.
- [17] "Columbia object image library (COIL-100)", Department of Computer Science, Columbia University, www.cs.columbia.edu/CAVE/research/softlib/coil-100.html