

Energy Consumption in Forward Osmosis Desalination Compared to other Desalination Techniques

Ali Shoeb Moon, Moonyong Lee

Abstract—The draw solute separation process in Forward Osmosis desalination was simulated in Aspen Plus chemical process modeling software, to estimate the energy consumption and compare it with other desalination processes, mainly the Reverse Osmosis process which is currently most prevalent. The electrolytic chemistry for the system was retrieved using the Elec – NRTL property method in the Aspen Plus database. Electrical equivalent of energy required in the Forward Osmosis desalination technique was estimated and compared with the prevalent desalination techniques.

Keywords—Desalination, Energy, Forward Osmosis, Separation

I. INTRODUCTION

WATER is essential to all known forms of life. Saline Water Oceans hold 97% of the surface water, glaciers and polar ice caps 2.4% and the other land surface water bodies such as rivers and lakes 0.6%. Although the earth has plenty of water, clean and potable water is becoming increasingly scarce. Its only 0.6% of the total water available in the form of rivers lakes and aquifers, which can be considered as fresh water i.e. the water containing low enough concentrations of dissolved salts to be considered safe for drinking and agriculture [1]. Presently, over one-third of the world's population lives in water-stressed countries and by 2025, this figure is predicted to rise to nearly two third. Sea water and brackish water desalination technologies can be of great respite to fight the menace of ever increasing demand of water due to rapid population growth, industrialization, contamination of available fresh water resources and climate change [2].

Earlier large scale desalination plants were based on thermal desalination, namely Multi Stage Flash Distillation (MSF) and Multi Effect Distillation (MED) where sea water is heated and the evaporated water is condensed to produce fresh water. But since the advent of Reverse Osmosis (RO) technology, where sea water is pressurized through a semi-permeable membrane which lets the water pass through it and retains salt, the vast majority of plants constructed in the recent decades are based on the same. As RO has been proved to be the most energy efficient process for desalination till now, therefore any new technology for water desalination has to be compared mainly with the RO in terms of energy efficiency [2].

Ali Shoeb Moon is with Yeungnam University, Gyeongsan 712749, South Korea.

Moonyong Lee is with Yeungnam University, Gyeongsan 712749, South Korea (phone: 82-53-810-3241; fax: 82-53-811-3262; e-mail: mynlee@ynu.ac.kr).

It was stated by McCutcheon, McGinnis, Elimelech [3] that a new desalination technology, Forward Osmosis (FO) can reduce the cost of water desalination further as compared to that of RO. Forward Osmosis just like RO, is a membrane process but here, natural osmotic pressure gradient rather than hydraulic pressure is made use of to create the driving force for water to permeate through the membrane. A 'Draw' solution that has a significantly higher osmotic pressure than the saline feed water is used at the other side of the membrane. Draw solution composed of ammonium salts formed from the mixture of Ammonia and Carbon dioxide gases was found to be most effective in terms of economy, osmotic pressure, easiness of removal and reuse [3]. It was further investigated by McGinnis and Elimelech [4] that the major advantages of the Forward Osmosis process include high feed water recovery, brine discharge minimization and relatively low energy requirements and cost. The schematic diagram of Forward Osmosis Desalination is shown in Fig. 1 which has been taken from [4]. This paper aims to analyze theoretically, the energy requirement for Forward Osmosis desalination process and compare that with Reverse Osmosis and other prevalent desalination techniques.

II. DRAW SOLUTE SEPARATION

It is assumed that the main energy intensive stage in FO process is the separation of Draw solute from the pure water, after it permeates through the semi-permeable membrane. A simple multi stage distillation column was considered in this study for the separation of Draw solute. The approach is to strip off the solute from the solution in the form of gases, Ammonia(NH₃) and Carbon Dioxide(CO₂) as the Top product, based on the fact that the equilibrium in the system between ionic and gaseous species(NH₄⁺ <-> NH₃; HCO₃⁻ <-> CO₃⁻ <-> CO₂) is shifted greatly towards the gaseous species at temperatures more than 70°C.

III. PROCESS MODELING

The separation process was modeled on Aspen Plus database. In Aspen Plus, all unit operation models can handle electrolytic system and it is possible to model a system containing sour water solutions with dissolved NH₃, CO₂, as the database provides specialized thermodynamic models and built in data to represent the non ideal behavior of liquid phase components. Elec-NRTL property method was used in this case and the solution chemistry for the system could easily be retrieved.

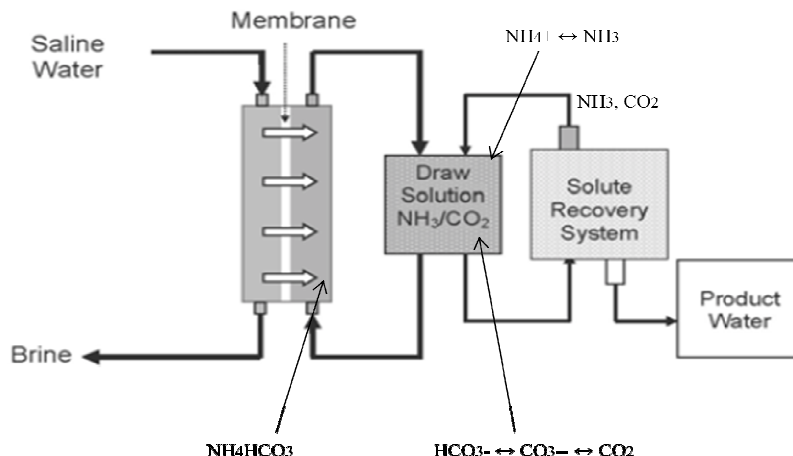

Fig. 1 Forward Osmosis Desalination Process

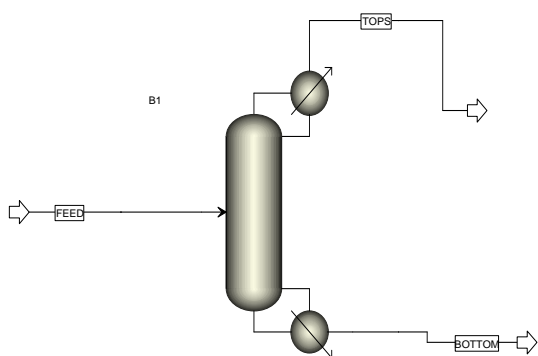

Fig. 2 Draw Solute Stripper Modeled on Aspen Plus

It was assumed that the draw solution entering the separation stage as feed has a concentration of Ammonium Bicarbonate between (0.5 – 1.5) M and the temperature of the feed is 20°C at atmospheric pressure. For the base case, distillate to feed ratio was specified as 0.122 and the number of stages as 11 including the reboiler. Entry of feed was specified above stage 1 and the reboiler pressure as 1atmospheres. Drinking water recovered at the bottom was specified to contain less than 5 ppm of Ammonia.

IV. EQUIVALENT WORK FOR DRAW SOLUTE SEPARATION

Thermal energy used for the Draw solution separation in Forward Osmosis process is deduced to an electrical energy equivalent for the purpose of effective comparison with the Reverse Osmosis process, in terms of energy requirements. It is assumed that that the steam used to supply thermal energy to the separation process is extracted from a steam turbine. The enthalpy of the steam at the point where it would normally enter the turbine condenser is subtracted from the enthalpy of the steam at the point where it is directed to the separation process. This difference in enthalpy is multiplied by the efficiency of the turbine (assumed to be 95%). Also the condenser temperature is assumed to be 35°C. The equation can be written as [4]:

$$Weq(kWh/m3) = [(H_{steam\ used} - H_{steam\ at\ condenser}) * E_{turbine} * 1000 * 0.00027] / GOR + Wel \tag{1}$$

Where, GOR stands for Gained Output Ratio, i.e. kg of water produced for each kg of steam used. And for the case of Forward Osmosis process, it can be obtained as [4]:

$$GOR = H_{vap\ steam} (kJ/kg) / Energy\ for\ FO (MJ/m3) \tag{2}$$

TABLE I
ENERGY REQUIREMENTS FOR DRAW SOLUTE SEPARATION IN FORWARD OSMOSIS DESALINATION

Draw Solution Concentration (mol/ L)	Pressure at Reboiler (atm.)	Temperature at Reboiler (°C)	Equivalent Heat Requirements (kWh/m3)	Total Equivalent Work (kWh/m3)
1	1	99.99	7.20	7.40
1	0.7	90.28	5.69	5.89
1	0.5	81.64	4.55	4.75
1	0.3	69.37	3.11	3.31

TABLE II
COMPARISON OF ESTIMATED ENERGY REQUIREMENT FOR FO DESALINATION TO PREVALENT DESALINATION TECHNIQUES

Desalination Technique	Equivalent Energy Requirement (kWh/m ³)
Forward Osmosis	3-8
Reverse Osmosis	4-6
Multi Effect Distillation (MED)	15-58
Multi Stage Flash Distillation (MSF)	21-58

Well, is the additional electrical energy requirements to pump the fluids within the separation system assumed to be around 0.20 kWh/m³ for the studied case. The factor 1000 is actually the density of water in kg/m³ to obtain the value per m³ of water. And 0.00027 is the conversion factor to convert the work obtained to the unit kWh from kJ. The calculations for total equivalent work required for draw solution separation in Forward Osmosis desalination process at different reboiler pressures and 1 M Draw solution concentration as a reference, are summarized in TABLE I.

V. COMPARISON WITH OTHER DESALINATION TECHNIQUES

The estimated value of electrical equivalent of energy consumed in the Forward osmosis desalination techniques is compared with the prevalent techniques in TABLE II. The energy requirement values for the other desalination techniques apart from the Forward Osmosis are quoted from [5]. It is clearly evident that the thermal energy required in the Forward osmosis desalination technique is much less than that required for evaporation based thermal desalination processes, Multi Effect distillation and Multi Stage Flash distillation. Moreover, electrical equivalent of the thermal energy required in FO desalination is in the range comparable to the Reverse Osmosis technology, which is considered to be the most energy efficient process for desalination purposes.

VI. CONCLUSIONS

From theoretical point of view it seems that Forward Osmosis process has the potential to reach up to the levels of the RO process or even better than that in terms of energy efficiency, especially when RO process has almost reached the theoretical thermodynamic limit in terms of energy consumption [5]. But more research is needed in the field of FO, especially some practical experimentation to prove its mettle against the ongoing and most prevalent RO process. Also, recycling of the draw solute to form the Draw solution should be taken into account in a better way through further practical study as in the present study it was assumed that major energy consuming step in Forward Osmosis desalination is only the Draw solute separation. Moreover, it would then be possible to clearly check the percent recovery of drinking water depending on the salinity of the inlet sea water and therefore to put forward more concrete results for comparison.

Once it is confirmed through practical observations that FO consumes equivalent or less energy than the RO process, the next step could be to try and optimize the process for example, with some heat integration schemes for the separation part and/or improving the quality of the membranes, to approach the thermodynamic limit. In a nutshell, it's too early to say that the Forward Osmosis desalination technique is good enough to wipe off completely the prevalent ones, primarily the RO desalination.

ACKNOWLEDGMENT

This work was supported by the Human Resources Development Program of Korea Institute of Energy Technology Evaluation and Planning (KETEP) grant (No. 20104010100580) funded by the Korean Ministry of Knowledge Economy.

REFERENCES

- [1] L. Wagner, Water Desalination – Tap into the Liquid Gold. Research report, Mora Associates, Dec 2007.
- [2] M. Elimelech, W.A. Phillip, the Future of Seawater Desalination: Energy, Technology and the Environment. Science, 5/8/2011, Vol. 333.
- [3] J.R. McCutcheon, R. L McGinnis, M. Elimelech, A novel ammonia-carbon dioxide forward osmosis desalination process. Desalination 174 (2005) 1- 11.
- [4] R.L. McGinnis, M. Elimelech, Energy Requirements of Ammonia-Carbon Dioxide Forward Osmosis Desalination. Desalination 207 (2007) 370-382.
- [5] R. Semiat, Energy issues in Desalination Processes. Environmental Science and Technology. Vol. 42, No.22, 2008.