

Effects of Water Content on Dielectric Properties of Mineral Transformer Oil

Suwarno, M. Helmi Prakoso

Abstract—Mineral oil is commonly used for high voltage transformer insulation. The insulation quality of mineral oil is affecting the operation process of high voltage transformer. There are many contaminations which could decrease the insulation quality of mineral oil. One of them is water. This research talks about the effect of water content on dielectric properties, physic properties, and partial discharge pattern on mineral oil. Samples were varied with 10 varieties of water content value. And then all samples would be tested to measure the dielectric properties, physic properties, and partial discharge pattern. The result of this research showed that an increment of water content value would decrease the insulation quality of mineral oil.

Keywords—Dielectric properties, high voltage transformer, mineral oil, water content.

I. INTRODUCTION

THE increasing capacity of electrical power generation requires a good electrical power system. High voltage transformer is very important in an electric power system. In general, high voltage transformers need liquid insulation as a coolant and as dielectric to withstand high electric field in composite with paper insulation [1]. Since long time ago, mineral oil is being used in the high voltage transformer. It is common that transformer oil contains an amount of water. However, it is limitation that the water content may affect the performances of the transformer oil. Therefore, investigation on the effects of water content on the dielectric properties of mineral transformer oils is very important. This paper presents the experimental results on the effects of water contents in dielectric properties such as breakdown voltage, losses factor, resistivity and color of mineral transformer oil.

II. EXPERIMENT

A. Sample

Sample used in this experiment is mineral oil which is widely used in high voltage transformers. The samples have different water contents. The water contents of the samples are shown in Table I. The saturated water content of mineral oil is determined according to [2]. The relative water content was calculated as the ratio between water content in ppm and the saturated water content of mineral oil. The level of water content was adjusted to meet the requirement. For small reduction the water can be slightly removed by heating method. The sample was put into a Schott Duran bottle and

then heated using oven for 24 hours with 120° C temperature. This method was used as a way to perform early conditioning in some experiments relating to the research of dielectric properties on mineral oil [3]. For further reduction of water content silica gel was used to absorb water from the samples [4]. This method is efficient enough and cost-effective.

TABLE I
SAMPLES AND THEIR WATER CONTENTS

Sample	Water Content (ppm)	Relative Water Content (%)
M01	12,00	16
M02	18,48	25
M03	28,00	38
M04	34,00	46
M05	41,30	56
M06	55,38	75
M07	61,14	83
M08	65,97	90
M09	70,57	96
M10	75,90	103

The appearance of the samples is shown in Fig. 1.



Fig. 1 The appearance of samples

B. Measurement

1. Dielectric Dissipation, Relative Permittivity, and D.C Resistivity Measurement

These measurements are conducted according to IEC Standard 60247 “Insulating Liquids – Measurement of Relative Permittivity, Dielectric Dissipation Factor (Tan δ), and D.C Resistivity” [5].

2. Water Content Measurement

Water content measurement refers to Karl Fischer method with ASTM D-1533 Standard [6]. This measurement used Karl Fischer KF875 as shown in Fig. 2.

3. Breakdown Voltage Measurement

Breakdown Voltage measurement was conducted using Megger OTS 80 AF/2 according to IEC Standard 60156 [7].

Suwarno, M. Helmi Prakoso are with School of Electrical Engineering and Informatics, Institut Teknologi Bandung, Indonesia, (e-mail: suwarno@ieec.org).

AC voltage was used at rise rate of 2 kV/s and applied to a bispherical electrode system as shown in Fig. 3.



Fig. 2 Kinematic Viscosity Bath



Fig. 3 Bispherical electrode system for measurement of breakdown voltage

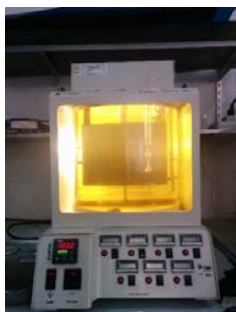

Fig. 4 Kinematic Viscosity Bath

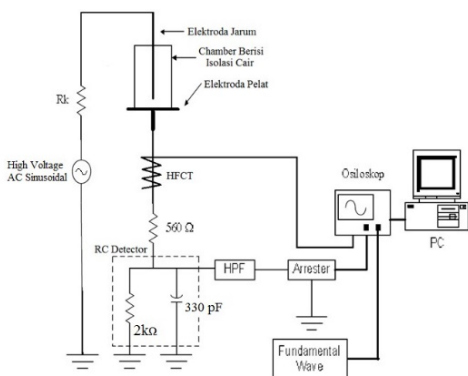

Fig. 5 Schematic circuit for PD measurement

4. Viscosity Measurement

Viscosity measurement was conducted using a Kinematic Viscosity Bath as shown in Fig. 4. The method of this measurement refers to ASTM Standard D-445[8].

5. Color Scale Measurement

Color scale measurement was done by a method that refers to ASTM Standard D-1500 [9]. Equipment that used for this measurement is Livobond PFX 195.

6. Partial Discharge Measurement

This measurement was done by using a PD measurement system as shown in Fig. 5 according to IEC Standard 60270 [10]. The digital data from oscilloscope were transferred to a personal computer for further analysis.

Needle-plane electrode with 3 mm distance between electrode was used. Needle electrode was made from steel by Ogura Jewellery with length of 5cm and diameter of 1mm. The tip part of electrode has 30° angle and 3µm radius. This electrode configuration was included inside a chamber of 1 L Schott Duran bottle within 450 ml sample of mineral oil.

III. EXPERIMENTAL RESULTS AND ANALYSIS

A. Breakdown Voltage

Fig. 6 shows the dependence of breakdown voltage on the water content. The figure clearly indicates that under dry condition (low than 20%) the breakdown voltage is very high as about 80 kV. In this condition water particles have a form as monomer and have a high dipole moment. When the relative water moisture is getting higher, the dipole moment is going down and the mobility of electron is getting high. This leads to the decrease of the dielectric strength of mineral oil. The result is that the breakdown voltage drastically reduced in the range of 20-50% of relative water content.

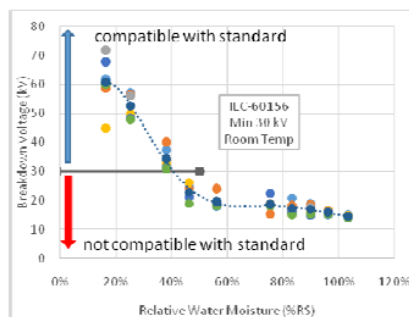

Fig. 6 Dependence of breakdown voltage on the water content

When the relative water content is above 50%, the breakdown voltage is about 18 kV which is almost constant although the water content increased significantly.

According to IEC 60156 the minimum breakdown voltage at room temperature is 30 kV. From Fig. 6 it can be seen that sample M01, M02 and M03 are compatible with the standard since their breakdown voltage are higher than 30 kV. The rest samples are not compatible with the standard.

B. Dielectric Dissipation Factor

Fig. 7 shows the dependence of dissipation factor on the water content. The graph clearly indicates that water content strongly affects the dissipation factor. The increase of the dissipation factor is almost linear with the increase of water

content. These results are similar with [11]. Dielectric dissipation factor illustrates dielectric losses in AC voltage. The higher value of $\tan \delta$ describes the decreasing insulation quality of mineral oil.

C. Relative Permittivity Measurement

Fig. 8 shows the dependence of relative permittivity on water content. The results indicate that the relative permittivity is about 2.3 and slightly increases with water content which reasonably similar with [12].

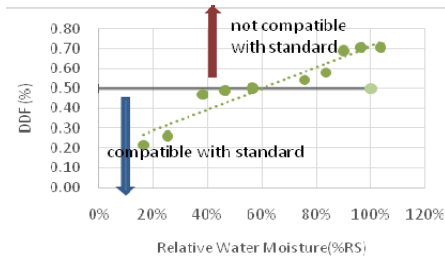

Fig. 7 Dependence of Dissipation Factor on Water content

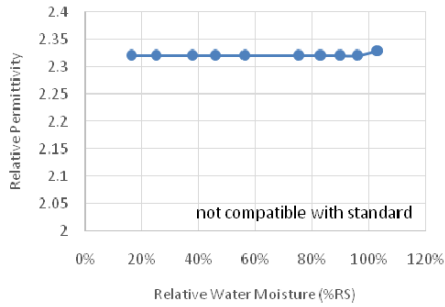

Fig. 8 Dependence of Relative Permittivity on Water content

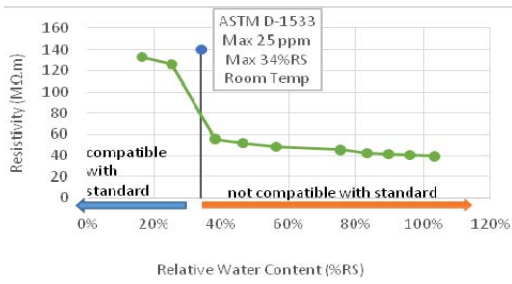

Fig. 9 Dependence of resistivity on water content

D. Resistivity Measurement

Fig. 9 shows the dependence of resistivity on the water content. The graph indicates that water content significantly reduces the oil resistivity especially at water content of more than 20 %. The resistivity of sample M01 with water content of 16 % was about 140 MΩ.m. This value drastically drops to about 60 MΩ.m when the water content increased to 38 % (sample M03). At water content of more than 40 %, the resistivity gradually reduced with the water content.

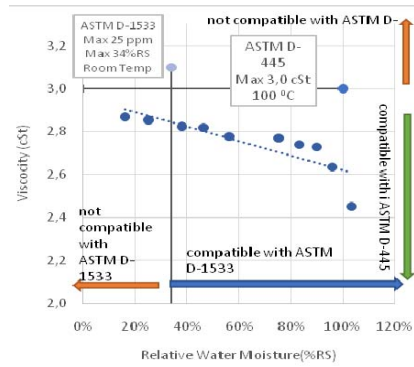

Fig. 10 Dependence of viscosity on water content

E. Viscosity Measurement

Fig. 10 shows the dependence of viscosity on the water content. The graph clearly shows that viscosity slightly reduced with the increase of water content.

F. Color Scale Measurement

Fig. 11 shows the dependence of oil color on the water content. It is seen that the oil color almost independent on the water content. All samples have color of 0.5 less than 1.0 which is compatible with ASTM D-1500.

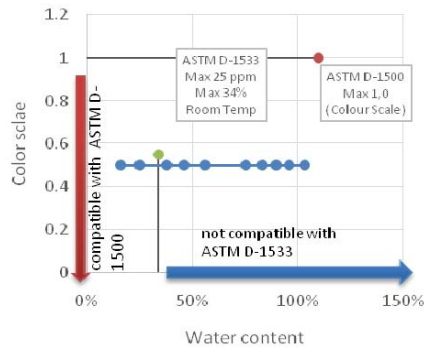

Fig. 11 Dependence of Color Scales on water content

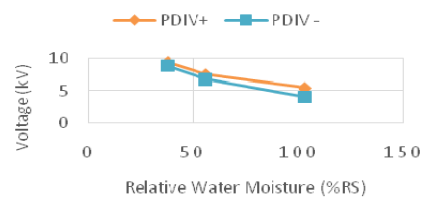

Fig. 12 Effect of Relative Water Moisture on PDIV

1. Partial Discharge Inception Voltage (PDIV)

PDIV is a minimum voltage required for a PD to occur. Fig. 12 shows positive and negative PDIV as function of water content. The experimental results show that PDIV significantly reduced with the water content. The negative PDIV is lower than positive PDIV. The negative and positive PDIVs of sample M03 are 8.9 kV and 9.4 kV and the PD pulses at the inception stage are shown in Fig. 13.

2. Partial Discharge Pattern

Fig. 14 shows $\phi - q - n$ PD patterns of sample M03, M05 and M10 at applied voltage of 11 kV.

The experimental results clearly show that PD intensity increase significantly with the increase of water content in oil. All PD patterns are similar with [13]-[15].

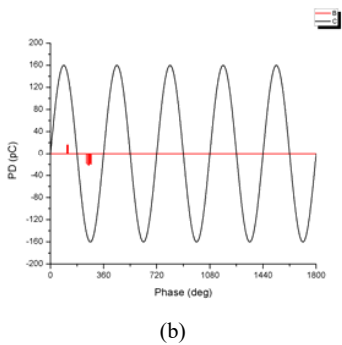
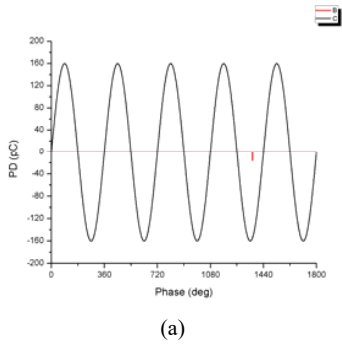

Fig. 13 (a) Negative and (b) positive PDIVs of sample M03

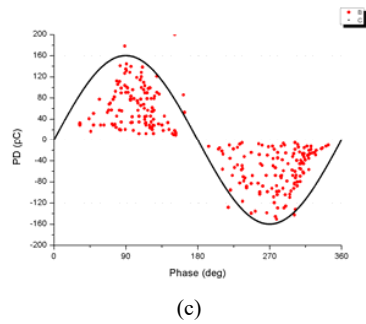
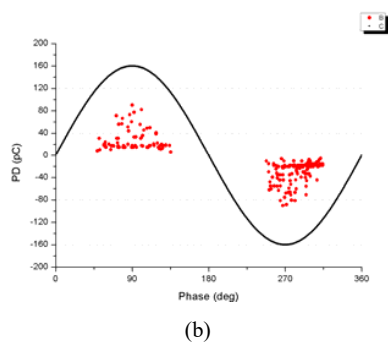
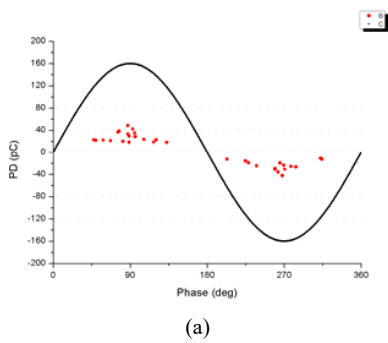

Fig. 14 $\phi - q - n$ PD patterns of Sample (a) M03 (b) M05 and (c) M10 at applied voltage of 11 kV

Fig. 15 shows the PD pulse sequences of the PD patterns presented in Fig. 14. The figure clearly indicates that PD in all samples is distributed at around the peak of applied voltage. The PD pulse number in each half cycle increased with the water content.

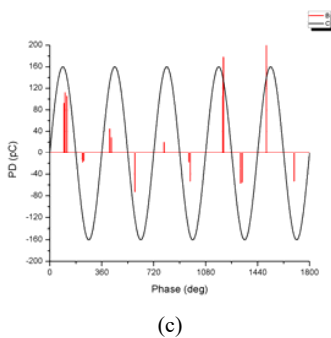
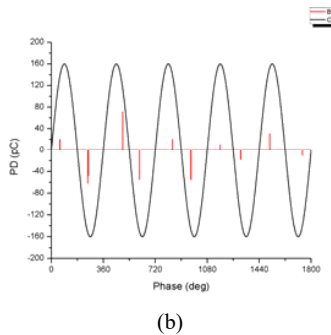
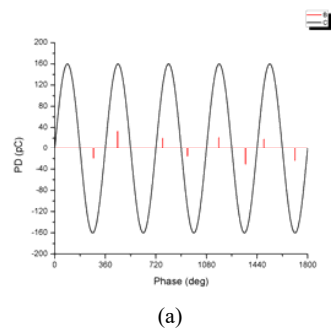

Fig. 15 PD pulse sequences of Sample (a) M03 (b) M05 and (c) M10 at applied voltage of 11 kV

The increase of electric field made the electron kinetic energy released from the needle tip to increase. The energetic electron will lead to the PD with higher repetition and magnitude.

3. Total Charge, Average Charge, and Numbers of Partial Discharge Characteristic

Table II shows the PD number, PD average charge and total PD charge at applied voltage of 10 and 11 kV within 50 cycles.

The table clearly indicates that water content strongly affects the PD activity in all samples. Water is a conductive particle. The raising value of water content in mineral oil would enlarge the possibility of partial discharge case. Partial discharge would also release higher energy because of the impact from water content treatment. Energy is proportional with charge ($E \sim q^2$), so PD charge would get higher when the energy is high.

The table also clearly shows that the increase of applied voltage from 10 kV to 11 kV greatly intensify the PD activity. The phenomena can be explained by the fact that the increase of applied voltage greatly intensifies the electric field (E) around the needle electrode which can be estimated by Mason equation [16], [17].

$$E = \frac{2V}{r \ln \left[\frac{4d}{r} \right]} \quad (1)$$

where E is electric field (kV/mm), V is the applied voltage (kV), d is the electrode separation (mm) and r is the tip radius of needle electrode (mm).

The calculated electric fields in the current experimental condition are shown in Table III.

TABLE II
PD NUMBER, AVERAGE AND TOTAL CHARGE

Sample	# PD	10 kV		11 kV		
		Q_{av} (pC)	Q_t (pC)	# PD	Q_{av} (pC)	Q_t (pC)
M03	16	11.94	191.1	32	26.95	862.5
M05	133	17.76	2362.3	223	28.67	6394.3
M10	274	29.41	8059.7	291	61.23	17817.94

TABLE III
CALCULATED ELECTRIC FIELD

d (mm)	r (mm)	Voltage (kV)	Electrical Field (kV/mm)
3	0,003	10	803,7891
3	0,003	11	884,168

IV. CONCLUSIONS

From the experimental results several conclusions can be drawn as the following. Relative water content above 20% would weaken the dielectric strength of mineral oil significantly and there would be a reduction of voltage breakdown value drastically. Samples with relative water content value above 50% would have the breakdown voltage

value which was tend to maintain in lower level. The water content strongly reduced the resistivity and at the same time promoted the dielectric dissipation factor. The change of water content only slightly influences the relative permittivity. The change of water content value was changing the viscosity value but all the samples still remain inside the standard level. The oil color only slightly affected by the water content. On the other hand the water content greatly promoted the intensity of partial discharges. PD inception voltage reduced significantly by the water content. PD repetition rate as well as PD magnitude is greatly affected by the water content in oil.

REFERENCES

- [1] Wang, S.-Q., Zhang, G.-J., Mu, H.-B., Suwarno, Tanaka, Y., Takada, T., Effects of paper-aged state on space charge characteristics in oil-impregnated paper insulation, IEEE Transactions on Dielectrics and Electrical Insulation, Vol. 19, No. 6, 2012, pp. 1871-1878.
- [2] Y. Du, A.V. Marnishev, Moisture Solubility for Different Condition Transformer Oil (water content). IEEE Transaction on Dielectric and Electrical Insulation, Vol. 8 No.5 October, 2001.
- [3] M. Koch, The Breakdown Voltage of Insulation Oil under the Influence of Humidity, Acidity, Particles and Pressure, Wroclaw, Poland: APTADM Conference, 2007.
- [4] I.A.R. Gray, Guide for The Purification of Insulating Oil, Transformer Chemistry Service.
- [5] IEC, Insulating Liquids-Measurement of Relative Permittivity, Dielectric Dissipation Factor and D.C. Resistivity, IEC, Standard Report 60247, 2004.
- [6] ASTM, Standard Test Method for Water in Insulating Liquids by Coulometric Karl Fischer Titration, ASTM, Standard ReportD1533, 2012.
- [7] IEC, Insulating Liquids-Determination of the Breakdown Voltage at Power Frequency-Test Method, IEC, Standard Report60156, 2008.
- [8] ASTM, Standard Test Method for Kinematic Viscosity of Transparent and Opaque Liquids (and Calculation of Dynamic Viscosity), ASTM, Standard Report D445, 2014.
- [9] ASTM, Standard Test Method for ASTM Color of Petroleum Products (ASTM Color Scale), ASTM, Standard ReportD1500, 2012.
- [10] IEC 60270, "High Voltage Test Techniques - Partial Discharge Measurements". IEC Standard Report 60270, 2000.
- [11] P. Tranka, V. Mentlik, The effect of moisture content on electrical insulating liquids, Pilsen, Czech Republic: University of West Bohemia, 2014.
- [12] Fofana, The electrical and dielectrical behaviour of mixed insulation liquids for transformers, Germany, University of Hannover, 1999.
- [13] Suwarno, F. Sipahutar, The Implementation of Needle-Plane Electrode Configuration and Test Method for Partial Discharge Inception Voltage Characteristic Measurement of Mineral Oil, International Journal on Electrical Engineering and Informatics, Vol. 5. 2013.
- [14] Suwarno, A model of streamer discharges in insulating liquid and computer simulation, Research Journal of Applied Physics, Vol. 4, No. 4, 2009, pp. 134-141.
- [15] Suwarno, Phase resolved measurement and simulation of partial discharges in solid and liquid insulating materials, Proceedings of the International Symposium on Electrical Insulating Materials, Niigata, Japan, 2014, pp. 46-49.
- [16] Mason, J. H., Deterioration and Breakdown Voltage of Dielectric Resulting from Internal Discharge, Proc. IEE, Vol.98, Part 1 (1951) pp 44-59.
- [17] Mason, J. H., Breakdown of Solid Dielectric in Divergent Fields, IEE Monograph127 M, 102 C, (1955) pp. 254-263.