

Effect of Tube Materials and Special Coating on Coke Deposition in the Steam Cracking of Hydrocarbons

A. Niaei, D. Salari, N. Daneshvar, A. Chamandeh, and R. Nabavi

Abstract—The steam cracking reactions are always accompanied with the formation of coke which deposits on the walls of the tubular reactors. The investigation has attempted to control catalytic coking by the applying aluminum, zinc and ceramic coating like aluminum-magnesium by thermal spray and pack cementation method. Rate of coke formation during steam cracking of naphtha has been investigated both for uncoated stainless steel (with different alloys) and metal coating constructed with thermal Spray and pack cementation method with metal powders of Aluminum, Aluminum-Magnesium, zinc, silicon, nickel and chromium. The results of the study show that passivating the surface of SS321 with a coating of Aluminum and Aluminum-Magnesium can significantly reduce the rate of coke deposition during naphtha pyrolysis. SEM and EDAX techniques (Philips XL Series) were used to examine the coke deposits formed by the metal-hydrocarbon reactions. Our objective was to separate the different stages by identifying the characteristic morphologies.

Keywords—Steam Cracking, Pyrolysis, Coke deposition, thermal spray, Pack Cementation.

I. INTRODUCTION

THE coils in pyrolysis furnaces used to produce ethylene, propylene and other valuable hydrocarbons are subjected to high temperatures and very hostile operating conditions. Nickel and iron present on the metal surface are believed to catalyze the production of coke and especially filamentous coke, through the formation of metal carbides [1]. Coke formation in naphtha cracking reactors decreased the product yields, heat transfer and reactor life. Although the time and money for decoking operations are increased Metallurgists have known for years that a highly efficient engineering material would result if the high temperature corrosion resistance of aluminum could be combined with the mechanical advantages of steel. Unfortunately, the adding aluminum to the steel melt as an alloying element is difficult. Also, the addition of more than eight atomic percent aluminum to a bulk alloy creates a brittle material at room

temperature, which is difficult to use as a structural component. Then much research is based on surface coating to solve these problems [2-4]. Much research on the formation of coke catalyzed by surfaces is based on attempts to solve these problems. Significantly effort has been expended to identify ways to passivate metal surface under high temperature pyrolysis conditions. The formation of metal oxide layers on alloy is reported to passivate the surface and reduce coking. Studding coke deposition in the pyrolysis of naphtha is designed and assembled by the authors. Effect of run time and temperature on morphology of coke formation in different metal surfaces was studied on the system. Chemical vapor deposition to coating chromium and nickel is used.

II. EXPERIMENTAL

A. Thermal Cracking Set Up

The experimental were conducted in a jet-stirred 321 stainless steel which had provision for measuring the kinetics of cracking as well as coking in a system designed are shown in Fig. 1. For measuring the coke deposition, the coupons were suspended into the reactor by means of a stainless steel wire.

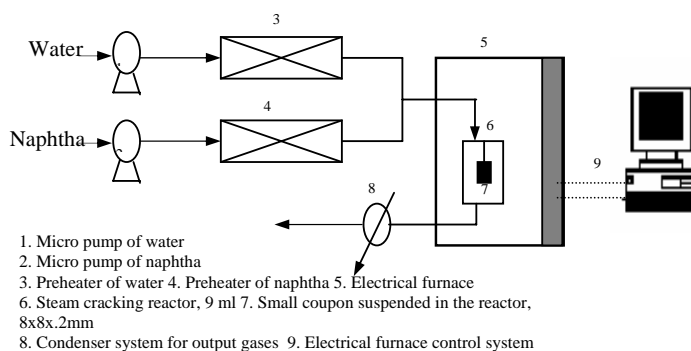

Fig. 1 Laboratory system for study of steam cracking and coke deposition

B. Packed Sementation and Thermal Spray Method for Coating

The pack mixture was used in a laboratory system contains metal powder, an inert filler such as alumina and halide

Manuscript received July 31, 2007.

A. Niaei is with the Department of Chemical Eng & Applied Chemistry, University of Tabriz, Tabriz, Iran (+983393076; fax: +984113340191; e-mail: niaei@yahoo.com).

D. Salari is with the Department of Chemical Eng & Applied Chemistry, University of Tabriz, Tabriz, Iran (e-mail: ddsalari@gmail.com).

activator such as ammonium chloride (Fig. 2). This method was used for coating of nickel and silicon. For coating the SS321 plate with zinc, aluminum and aluminum-magnesium powders, thermal spray method was used in a laboratory system.

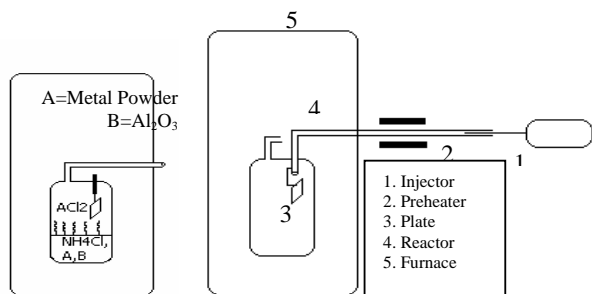

Laboratory system for metal coating with the pack cementation (left) and thermal spray (right) method

III. RESULTS AND DISCUSSION

A. Coke Formation Studies

Several metal surfaces were used in varying run time and the rate of coke formation was investigated. Amount of coke formation on nickel coated and SS321 coupons were very high. But chromium coated SS321 not only has noncatalytic effect but also passivate catalytic activity of iron and nickel. The rate of coke formation on silicon SS321 coated coupons during the first hours decreases the catalytic activity of metal wall and other coking mechanisms. The catalyzing intensity of coke deposition decreases in the order nickel > SS321 > Chromium > silicon. The rate of coke formation increased with temperature for nickel and chromium coating. But in silicon coating rate of coking in high temperature reduced significantly. On the aluminized SS321 coupons the rate of coke formation during the first hours not only decreases the catalytic activity of metal wall but also decrease the other coking mechanisms. It seems alumina was constructed protects reaction involving iron and nickel. Furthermore, in the first hours operation the coking rate decreased significantly but with aluminum-magnesium coupons coated, the rate of coke formation were essentially constant entire the operation. Results obtained from zinc plates coated confirm that decoking is taking place during pyrolysis so that increasing temperature, rate of decoking is speedier than rate of coking.

B. References Morphology Studies

Morphology of coke formation on silicon-coated coupons was studied in varying run times and temperatures. A first finding is that the morphology of the coke deposition was similar together in varying run times (0.5, 1.5, 2.5 hr) and second finding is that mechanism of coke formation is noncatalytic and no filamentous was consisted on silicon coating (Fig. 3) whereas on nickel and iron thick filamentous was formed (Fig. 4).

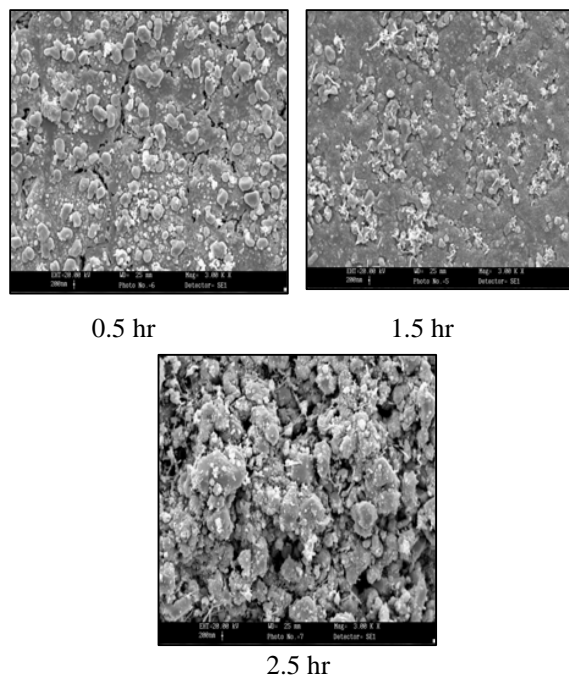

Fig. 3 SEM photomicrograph of coke deposited on silicon coating (Si) in varying times

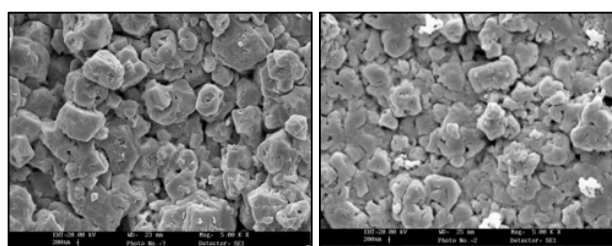

Fig. 4 SEM photomicrograph of coke on Ni (left) and iron plate (right)

With adding magnesium to aluminum micrograph of aluminum coating completely was changed (Fig. 5) and rate of coke formation was decreased appreciable. It seems a ceramic-like spinel is constructed. This ceramic-spinel structure increases the surface hardness so that resisted to coking and carbonization.

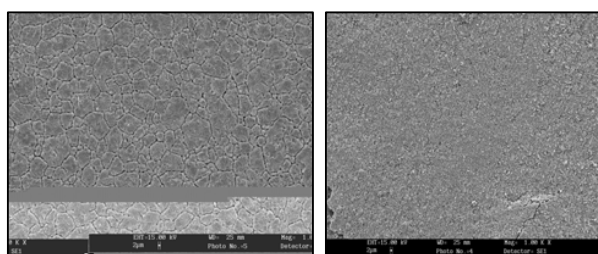

Fig. 5 SEM photomicrograph of aluminum coating on SS321 (left) and aluminum-magnesium coating on SS321 (right)

Morphology of the coke deposition on aluminized SS321 and aluminum-magnesium coated coupons often was similar together. As depicted in Figs. 6 and 7, the predominant structure of coke observed on the surfaces tended to be a film of tar or globular coke deposit and important point is that when temperature is increased filamentous coke is appeared on surface coating.

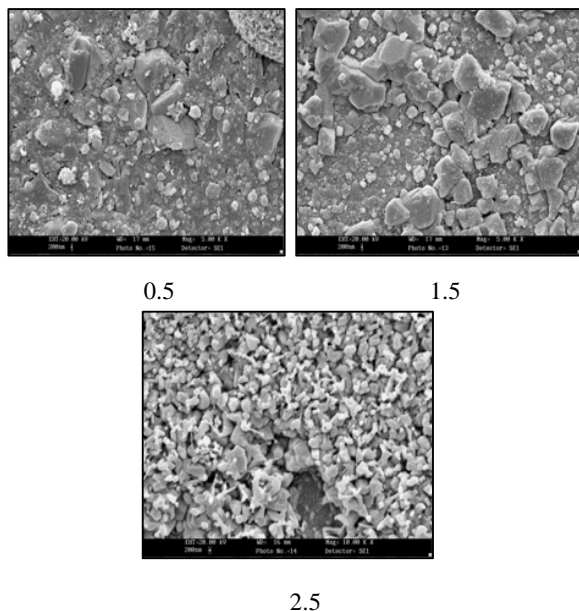

Fig. 6 SEM photomicrograph of coke deposition on aluminum coating as a function of run time (h)

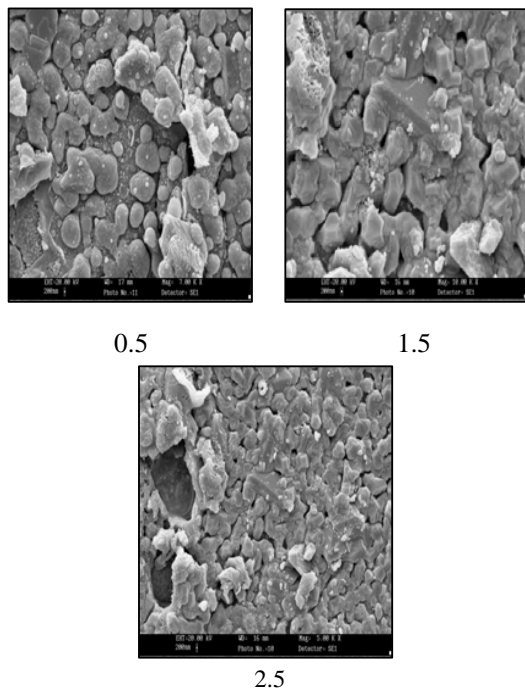

Fig. 7 SEM photomicrograph of coke deposition on aluminum-magnesium coating as a function of run time

IV. CONCLUSION

Pack cementation method was used for coating of nickel, silicon and chromium on S321. Thermal spray method was used for making an aluminum, aluminum-magnesium and zinc coating on S321. The investigations show that the rate of coke deposition during naphtha pyrolysis can be significantly reduced by passivating the SS321 surface with a coating of aluminum and aluminum-magnesium, nickel, silicon, chromium and zinc, so that an aluminum-magnesium surface is resisted to coking in high temperature. The results obtained from zinc-coated show decoking carry out during thermal cracking, so that with increasing run time and temperature rate of decoking was speedier than the rate of coking. Comparison of scanning electron microscope (SEM) of coke deposited on the metal surfaces is detected that after passivating these micrographs are similar together and when temperature is increased, mechanism of coke deposition changed and filamentous coke is appeared on coated surface.

REFERENCES

- [1] L. F. Albright, and B. L. Crynes, Tan, L. F., "Thermal Cracking", Encyclopedia of Physical Science and Technology, Ed. New York: McGraw-Hill, 2002, Vol.16, pp.613.
- [2] L.F. Albright, W. A. Gill, "Aluminized Ethylene Furnace tubes Extend Operation Life", *Oil & Gas J.* 47-50. 1987
- [3] K. Wynny, A. Bayer, "Diffusion Coated Ethylene Furnace tubes", U.S. Patent, 5873951. 1999.
- [4] K. Wynny, A. Bayer, "Surface Alloy System Conversion For High Temperature Application", U.S. Patent, 657388B1. 2003.

A. Niaei was born in 1963. He received his B.Sc. degree (1989) in Chemical Engineering from Esfahan University of Technology, M.Sc. degree (1989) in Chemical Engineering from Tarbiat Modares University, Tehran, Iran. From 1992 to 1997 he was a member of the academic staff in University of Tabriz. In 1997 he joined the Olefin Research Group (ORG) at University of Tarbiat Modares and he received his Ph.D. working on coke inhibitors in hydrocarbons thermal cracking in 2002. He is currently a staff member at the Department of Applied Chemistry & Chemical Engineering in University of Tabriz. His research interests include thermal cracking of hydrocarbons, modeling, simulation and optimization of thermal cracking process and catalytic reaction engineering.