

Dynamic Performance Analysis of Distribution/ Sub-Transmission Networks with High Penetration of PV Generation

Cristian F.T. Montenegro, Luís F. N. Lourenço, Maurício B. C. Salles, Renato M. Monaro

Abstract—More PV systems have been connected to the electrical network each year. As the number of PV systems increases, some issues affecting grid operations have been identified. This paper studied the impacts related to changes in solar irradiance on a distribution/sub-transmission network, considering variations due to moving clouds and daily cycles. Using MATLAB/Simulink software, a solar farm of 30 MWp was built and then implemented to a test network. From simulations, it has been determined that irradiance changes can have a significant impact on the grid by causing voltage fluctuations outside the allowable thresholds. This work discussed some local control strategies and grid reinforcements to mitigate the negative effects of the irradiance changes on the grid.

Keywords—Utility-scale PV systems, reactive power control, solar irradiance, voltage fluctuation.

I. INTRODUCTION

THE global cumulative capacity of photovoltaic (PV) generation has increased exponentially in the last ten years, reaching 178 GW in 2014 [1]. In the following years, the number of PV systems will continue to increase and PV cumulative capacity will likely exceed 400 GW worldwide by 2020 with China, Germany, USA and Japan as major markets [2].

In Brazil, the growth of PVs has not followed the international trend. By October 2015, PV systems contributed to only 0.02% of the total electric generation in the country [3]. However, the electricity market operator (CCEE) announced thirty-one new solar farms with an overall capacity of 889 MWp by 2017. These projects will be mainly located in the states of Bahia (14 projects) and São Paulo (9 projects). Moreover, twenty-nine of them will have a capacity of 30 MWp [4].

The increasing number of PV systems connected to the electrical network has caused impacts on grid operations. According to [5], when PV generation exceeds the local load of a distribution network, reverse-power-flows occur toward upstream voltage levels resulting in voltage rises. Moreover, uncertainty and variability of PV power can affect the operation of the grid regarding voltage regulation. These issues are related to changes in solar irradiance due to daily cycles and meteorological phenomena, such as moving clouds

C.F.T. Montenegro, L.F.N. Lourenço, M.B.C. Salles and R.M. Monaro are with the Department of Electric Energy and Automation of the Polytechnic School of the University of Sao Paulo, SP, Brazil (phone: +5511 3091 5533; e-mails: cristiantomo@usp.br, lfnlourenco@usp.br, mausalles@usp.br, monaro@usp.br).

[6]. Research presented in [6] shows the effect of irradiance changes on a real-life network with a rooftop PV system. It finds that moving clouds can cause voltage fluctuations outside the allowable thresholds depending on the network loading. In utility-scale PV systems, as projected in Brazil, solar production is concentrated in a limited geographic region. Thus, it is very likely to lose a considerable amount of PV power by cloud coverage, potentially affecting the operation of the grid.

Mitigating voltage fluctuations due to PV generation is studied in [7], it proposes control strategies that allow PV systems to inject or absorb reactive power using PV inverters. This can help to reduce voltage variations caused by changes in solar irradiance levels.

This paper analyzes the effect of solar irradiance changes on the operation of a distribution/sub-transmission network with a utility-scale PV system. It has been modeled a solar farm with a capacity of 30 MWp in accordance with the discussed projects that are underway in Brazil. Alternatives to mitigate the negative effects on voltage regulation have been investigated. They are related with reactive power compensation by the PV system and grid reinforcements.

This work is structured as follows: Section II includes a 30 MWp solar farm model, corresponding to one of the 29 new projects under construction in Brazil and presents the test network; Section III presents the disturbances in power output that may occur due to variations in solar irradiance levels and control strategies considered in this paper; Section IV presents the results and their discussion and, finally, Section V presents the conclusions.

II. TEST SYSTEM

A. Solar Farm

The solar farm modeled in this work is composed of twenty identical PV systems of 1.5 MWp connected in parallel. The model (Fig. 1) is based on [8] and contains a PV generator, voltage source converter (VSC), current based control with a DC voltage loop, maximum power point tracker (MPPT) and a phase-locked loop (PLL). Each system is connected to a 12.47 kV grid at the point of common coupling (PCC) through a RL filter and a wye-delta transformer. The value of 1.5 MWp was chosen according to inverter stations available in the market.

PV system parameters have been summarized in Table I.

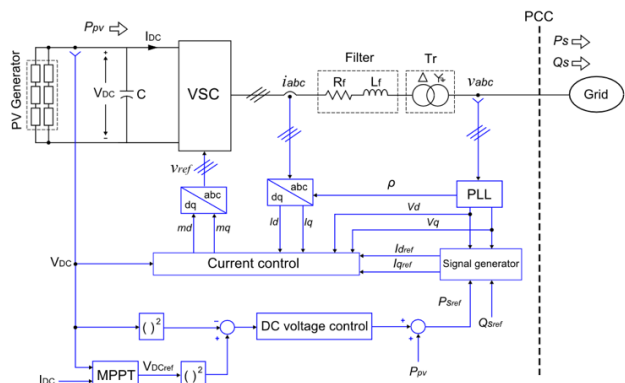

Fig. 1 PV system layout

TABLE I
PV SYSTEM PARAMETERS

Parameter	Value	Parameter	Value
PV module type	KD205GX-LP	MPPT sampling	1000 Hz
# of PV modules	62 × 144	MPPT ΔV_{ref}	13 V
VSC type	PWM, average model	PLL [Kp, Ki, Kd]	[180, 3200, 1]
C	6000 μ F	I controller Ki	1
R_f	1 m Ω	I controller Kp	0.0814
L_f	40.7 μ H	V controller α_1	-0.75
T_r voltage ratio	12.47/0.48 kV	V controller α_2	-909
T_r rating	1.5 MVA	V controller α_3	2309
T_r leakage inductance	0.1 pu		

B. Test Network

The solar farm is connected at bus 6 of a 33 kV distribution network through a 33/12.47 kV wye-wye transformer (Fig. 2). The distribution network is powered by a sub-transmission system of 132 kV and short circuit level of 1500 MVA via two transformers of 132/33 kV connected in delta-wye.

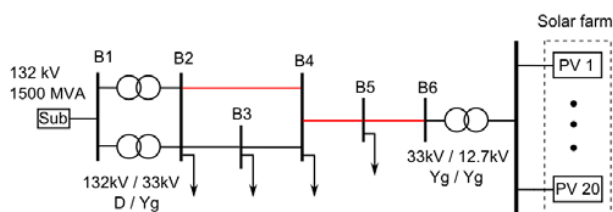

Fig. 2 Diagram of the test network

III. METHODOLOGY

A. Changes in Solar Irradiance

A typical curve of daily solar irradiance is shown in Fig. 3; it is possible to identify the disturbances studied in this work. First, daily cycle variations match a parabolic shape with maximum at noon and zero values at night. Second, moving clouds cause random variations distorting the shape of the curve. This work studies the effect of these disturbances separately.

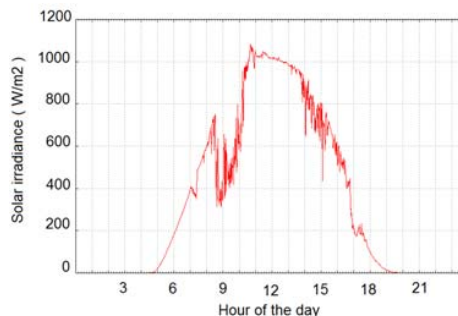

Fig. 3 Typical daily solar irradiance curve [9]

B. Voltage Control Strategies

Three techniques to mitigate voltage fluctuations caused by irradiance changes proposed in [7] have been investigated:

- Grid reinforcements of red lines shown in Fig. 2.
- Constant 0.95 (lagging) power factor operation.
- Dynamic compensation of reactive power following the strategy illustrated in Fig. 4.

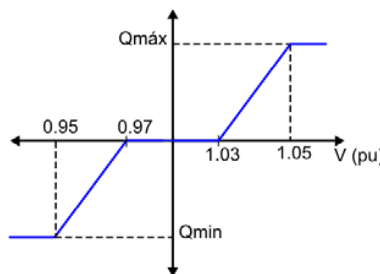

Fig. 4 Dynamic compensation of reactive power strategy [7]

IV. RESULTS AND ANALYSIS

A. Effect of the Daily Cycle

Fig. 5 (a) shows the typical behavior of solar irradiance in a sunny day. Data was collected in a US location with a sample period of one hour [10]. Solar irradiance reaches its peak at noon (945 W/m²) and remains zero during night hours. This curve was used to analyze the effect of the daily cycle of solar irradiance on the grid.

Fig. 5 (b) illustrates the active power injected by the solar farm operating at unity power factor during a daily cycle. The total load of the distribution network has been assumed constant and equal to 15 MW. By comparing Figs. 5 (a) and (b), it is observed that PV power follows the shape of solar irradiance. Moreover, PV generation exceeds the load between 10 and 17 hours which leads to the appearance of reverse power flows. This is confirmed in Fig. 5 (c) where it is shown that active power in the bus 2 is negative in this period, indicating a change in the direction of the power flow. PV generation also affects the voltage at the PCC, increasing its magnitude to 1.1 p.u. at noon as seen in Fig. 5 (d).

The impact of reverse power flows on voltage regulation has been analyzed with five loading scenarios (Fig. 6). In each case, the ratio between PV peak power and the total load of the distribution network varies, from 0.29 to 3. Reverse power

flows occur when this ratio is higher than 1. Fig. 6 shows the maximum voltages in the buses of the distribution network during a daily cycle. It illustrates that higher voltage levels occur in scenarios with reverse power flows. In these cases, maximum voltage values exceed the common limit of 1.05 pu in at least two buses.

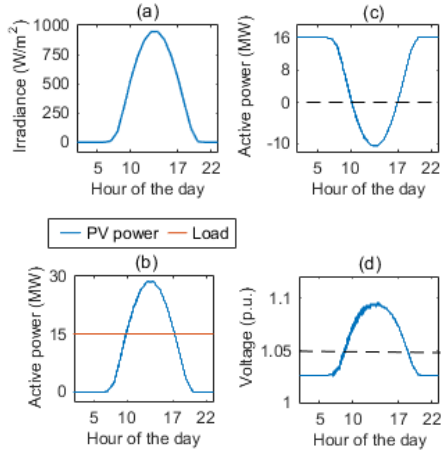

Fig. 5 Daily irradiation cycle and its consequences to the network. (a) Daily irradiance cycle. (b) Power generated by the solar farm. (c) Active power in bus 2. (d) Voltage measured in bus 6

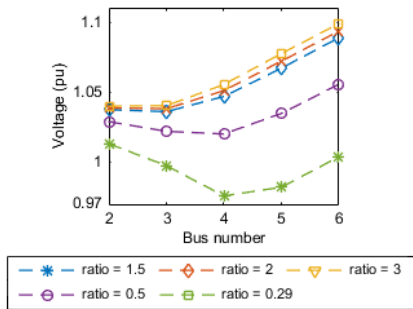

Fig. 6 Maximum bus voltage over a daily cycle

To attenuate reverse power flows consequences to voltage regulation, all voltage control strategies presented in Section III.B were implemented when the ratio between PV generation and load is equal to 2. The results are in Fig. 7. Fig. 7 shows the improvement in voltage regulation when each of the control strategies proposed in Section III.B is implemented. Compared to unity power factor operation, all strategies are able to reduce voltage levels over the buses with significant differences between them. The less effective strategy is grid reinforcements, which has significant effect only over buses 5 and 6, and it is also the strategy with higher cost. Dynamic reactive power injection based on Fig. 4 presents effective results on all buses, keeping the whole network with voltage levels under 1.05 p.u. Finally, constant power factor as 0.95 strategy shows the best improvement in voltage regulation because it achieves the highest levels of voltage reduction. However, operating the solar farm with 0.95 constant power

factor is not necessary. To prove this, Fig. 8 shows the maximum voltage level of each bus varying the ratio between PV generation and load from 0.29 to 3 under the daily cycle of Fig. 5 (a) for all PV groups and 0.95 constant power factor. When the ratio is 0.29, the voltage levels in buses 4, 5 and 6 drops below the 0.95 p.u. limit. Given the variability of PV generation, situations like this might happen during the day, so constant power factor operation is not the most reliable strategy to keep voltage regulation within the allowable thresholds.

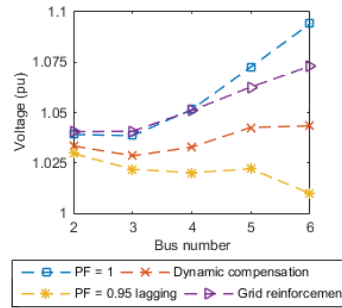

Fig. 7 Maximum bus voltage over a daily cycle including voltage control

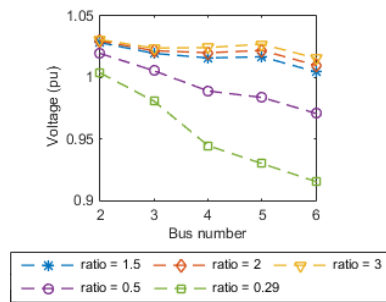

Fig. 8 Maximum bus voltage over a daily cycle (0.95 power factor)

B. Effect of Uniform Moving Clouds

To simulate the effect of uniform moving clouds, all PV groups of the solar farm were submitted to the profile exhibited in Fig. 9 (a). This profile represents a random behavior of solar irradiance that disturbs the PV system for 60 seconds. The generated power in this period is shown in Fig. 9 (b) and follows the solar irradiance shape from Fig. 9 (a) as the solar farm is equipped with a MPPT control that keeps the solar farm at its optimum operating point.

Fig. 9 (c) shows the voltage levels in bus 6 over the moving clouds disturbance period for two load conditions. In lighter colors is shown the obtained voltage levels over unit power factor operation and in darker colors, the obtained voltage levels through dynamic compensation of reactive power strategy shown in Fig. 4. It also shows that bus 6 voltage levels, for both load cases and control strategies, followed the solar irradiance shape and that dynamic reactive power has a better effect on voltage regulation than unit power factor operation, keeping the voltage levels close to the allowable

thresholds. Finally, Fig. 9 (d) shows the injected reactive power for both load cases.

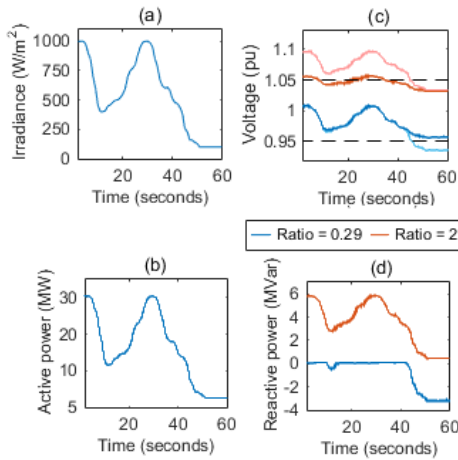

Fig. 9 Effect of moving clouds on voltage regulation. (a) Solar irradiance profile. (b) Active power injected by the solar farm. (c) Bus 6 voltage levels for two load conditions. (d) Reactive power on bus 6 for two load conditions

C. Effect of Non-Uniform Moving Clouds

In Section IV (B), all the PV groups of the solar farm were submitted to the same solar irradiance profile. In this section, all PV groups are submitted to the same pattern shifted in time, simulating a cloud in movement that affects all PV groups but not simultaneously. The mentioned patterns are shown in Fig. 10.

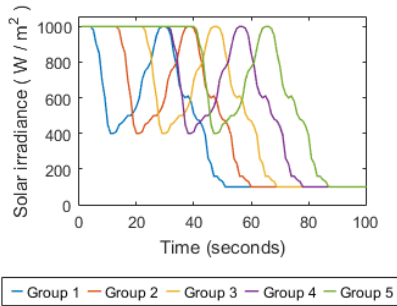

Fig. 10 Moving cloud irradiance profile

To demonstrate the impact of moving clouds in the system if none of the additional control strategies detailed in Section III B are implemented, the pattern exhibited in Fig. 10 was applied to three different ratios between PV peak power and the total load of the distribution network were analyzed as shown in Fig. 11. It can be noted from Fig. 11 that for all ratio scenarios bus 6 voltage levels exceed the allowable thresholds.

Detailing the analysis for a 3.5 ratio between PV peak generation and peak load, voltage levels over buses 4, 5 and 6 were observed. The result are in Fig. 12 shows that in steady state buses 5 and 6 voltage levels are below 0.95 p.u..

The results demonstrate that there is a need of a control strategy to keep voltage levels between the allowable

thresholds. The simulations from Figs. 11 and 12 were repeated with dynamic reactive power control strategy implemented. The results are in Figs. 13 and. 14.

The analysis of the results from Figs. 13 and 14 shows the improvement in voltage regulation when the dynamic reactive power injection is implemented. For a 3.5 ratio scenario, voltage levels are between the 0.95 p.u. and 1.05p.u. for the whole cloud disturbance period.

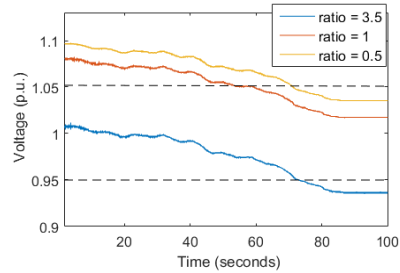

Fig. 11 Bus 6 voltage levels for three ratio scenarios

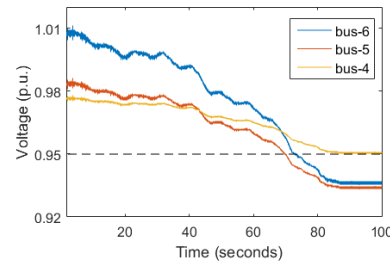

Fig. 12 Voltage level over three system buses for a 3.5 ratio

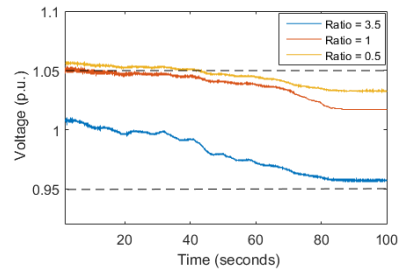

Fig. 13 Bus 6 voltage levels for three ratio scenarios with dynamic reactive power injection

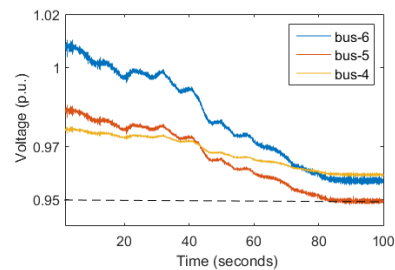

Fig. 14 Voltage level over three system buses for a 3.5 ratio with dynamic reactive power injection

V. CONCLUSION

This paper has investigated the impact of solar irradiance changes on a distribution/sub-transmission network with a 30 MWp solar farm. It analyzed the effect of moving clouds and daily cycles on voltage regulation. Major findings are summarized as:

- Changes in solar irradiance can have a significant impact on the grid by causing voltage fluctuations outside the allowable thresholds.
- Automatic compensation of the reactive power at the point of common coupling improves voltage regulation during irradiance changes. The PV system can supply this compensation using the capability of its inverters to generate or absorb reactive power. This is achieved with the implementation of local controls that operate according to bus voltage levels.
- Proposed grid reinforcements have less effect on voltage regulation during irradiance changes than the one achieved by local controls.

REFERENCES

- [1] Solar Power Europe, "Global market outlook for solar power 2015 - 2019," European Photovoltaic Industry Association, Bruxelles, Tech. Rep., 2015. (Online). Available: <http://www.solarpowereurope.org/>
- [2] P. Frankl, S. Nowak. "Technology Roadmap: Solar Photovoltaic Energy: OECD/IEA", 2010.
- [3] ANEEL (Agência Nacional de Energia Elétrica – in Portuguese), "Capacidade de Geração do Brasil", 2015.
- [4] CCEE (Câmara de Comercialização de Energia Elétrica – in Portuguese), "6º Leilão de Energia de Reserva", 2014.
- [5] von Appen, Jan, et al. "Time in the sun: the challenge of high PV penetration in the German electric grid" *Power and Energy Magazine, IEEE* 11.2 (2013): 55-64.
- [6] Yan, Rui Feng, Stephanie Roediger, and Tapan Kumar Saha. "Impact of photovoltaic power fluctuations by moving clouds on network voltage: A case study of an urban network." Universities Power Engineering Conference (AUPEC), 2011 21st Australasian. IEEE, 2011.
- [7] Tan, Yun Tiam. "Impact on the power system of a large penetration of photovoltaic generation." 2007 IEEE Power Engineering Society General Meeting. 2007.
- [8] Yazdani, Amirnaser, et al. "Modeling guidelines and a benchmark for power system simulation studies of three-phase single-stage photovoltaic systems" *Power Delivery, IEEE Transactions on* 26.2 (2011): 1247-1264.
- [9] NREL, National Renewable Energy Laboratory. MIDC Research Stations. Available online <http://www.nrel.gov/midc/research/>, accessed 2015/04/10.
- [10] Solar anywhere Irradiance and weather data, available online <http://www.solaranywhere.com>, accessed 2015/01/20.