

Dual Mode Navigation for Two-Wheeled Robot

N.M Abdul Ghani, L.K. Haur, T.P.Yon, F Naim

Abstract—This project relates to a two-wheeled self balancing robot for transferring loads on different locations along a path. This robot specifically functions as a dual mode navigation to navigate efficiently along a desired path. First, as a plurality of distance sensors mounted at both sides of the body for collecting information on tilt angle of the body and second, as a plurality of speed sensors mounted at the bottom of the body for collecting information of the velocity of the body in relative to the ground. A microcontroller for processing information collected from the sensors and configured to set the path and to balance the body automatically while a processor operatively coupled to the microcontroller and configured to compute change of the tilt and velocity of the body. A direct current motor operatively coupled to the microcontroller for controlling the wheels and characterized in that a remote control is operatively coupled to the microcontroller to operate the robot in dual navigation modes.

Keywords—Two-Wheeled Balancing Robot, Dual Mode Navigation, Remote Control, Desired Path.

I. INTRODUCTION

An inverted pendulum model can be described as a pendulum which has its mass above its pivot point. Thus, with the uniqueness and unstable nature of the system, it requires good control systems which capable to control itself in upright position dynamically balanced. Indeed, various types of controllers have been greatly implemented by the robotics researchers around the world currently such as Pole-placement, Linear Quadratic Regulator (LQR), Proportional-Integral-Derivative (PID), Fuzzy Logic and so forth.

In this project, this two-wheeled robot that equipped with self-balancing platform in order to keep balance while navigated on flat terrain is being developed. However, the navigation function is expanded with wireless PS2 controller due to its faster response and stable transmission. The receiver that plugged to the PSC28A PS2 I/O converter would receive the signal from the PS2 controller. From here, the microcontroller of the Brain Board which connected to the converter will collect the signal data, so that appropriate instruction will be sent to the Balance Board for further

N.M Abdul Ghani is with the Electrical & Electronics Engineering Faculty, Universiti Malaysia Pahang, 26600 Pekan Pahang (phone +609-4242110; e-mail: normaniha@ump.edu.my)

L.K Haur is with the Electrical & Electronics Engineering Faculty, Universiti Malaysia Pahang, 26600 Pekan Pahang (e-mail: jasonlkh_87@hotmail.com)

T.P.Yon is with the Electrical & Electronics Engineering Faculty, Universiti Malaysia Pahang, 26600 Pekan Pahang (e-mail: pokemon_tpy@hotmail.com)

F Naim is with the Electrical & Electronics Engineering Faculty, Universiti Malaysia Pahang, 26600 Pekan Pahang (e-mail: faradilan@ump.edu.my)

navigation with desired speed and direction. Instead, the speed of the platform is acquired by the BEMP motor velocity sensor. The entire control algorithm that computed in C programming will react against various of velocity and tilt angle which detected by the ground sensors of GP2D120 infrared sensor of the two-wheeled mobile robot.

II. LITERATURE REVIEW

The researchers from the Industrial Electronics Laboratory at the Swiss Federal Institute of Technology, Lausanne, Switzerland had successfully implemented a scaled down prototype of a Digital Signal Processor controlled two-wheeled vehicle based on inverted pendulum model with weights attached to the system to simulate a human driver, namely JOE. In brief, the control system used to achieve the stability of the system is based on two state-space controllers, utilizing sensory information from a gyroscope and two incremental encoders mounted on each dc motor [1].

And yet another two-wheeled balancing robot similar to JOE developed by David P. Anderson which makes use of commercially available inertial sensor and the position information from the motor encoder to balance the system, called nBot. The mobile robot would remain balanced as the system could able to drive the two wheels in the direction that the upper part of the robot is falling. Four terms used to define the motion and position of the system which then summed and fed back to the platform as a motor voltage that is proportional to torque in order to balance and drive the robot [2]:

- i. The tilt angle
- ii. Its first derivative, the angle velocity
- iii. The platform position
- iv. Its first derivative, the platform velocity

Apart from that, Steven Hassenplug who had successfully built a two-wheeled robot called Legway using the LEGO Mindstorms robotics kit. However, two Electro-optical Proximity Detector sensors which based on the Infrared Proximity Detector circuit were used in order to provide the tilt angle of the robot to the controller which programmed in BrickOS, so that a constant distance to the ground can be maintained [3].

In the paper by Peter Miller on building a two-wheeled balancing robot stated that some important elements in designing a stabilize two-wheeled robot system such as inertial sensors, shaft encoders, control algorithm and microcontroller as the brain of the robot to complete computations and process data by executing instruction or programming [4]. However, fuzzy logic controller is implemented in order to ensure the stability of the system.

Finally, the MATLAB is chosen as the simulation platform to work for stability and locomotion analysis throughout the system designed.

Similarly, Zatil Hanan from Universiti Teknologi Malaysia who taken the research project on position control of two-wheeled inverted pendulum mobile robot described that the mobile robot would balance on its own body and always place on the center of gravity as both the values of two analog reading GP2D120 IR distance sensor produce the same value. Instead, the GP2D12 is chosen to work as the input for the path control algorithm [5].

Moreover, under the research in [6] of modeling and control of a balancing robot using digital state space approach defined that the modeling is the crucial process of identifying the principal physical dynamic effects to be considered in analyzing a system, whereby the differential and algebraic equations are written based on the conservation laws and property laws of the relevant discipline, and then reduced them to a convenient differential equation model. The dynamic performance of a balancing robot depends greatly on the efficiency of the control algorithms and the dynamic model of the system. Despite, some assumptions and limitations had been mentioned to make the modeling of the mobile robot a reality which stated as below:

- i. Motor inductance is neglected and the current through the winding is not considered in the equation of the motion of the motor
- ii. The wheels of the robot will always stay in contact with the ground
- iii. There is no slip at the wheels
- iv. Cornering forces are negligible

The two-wheeled balancing robot requires a control algorithm in order to achieve the stability of dynamics of the system. Basically, it can be divided into two major types of control system: linear and non linear control system. The linear control system consists of proportional-integral-derivative (PID), linear quadratic regulator (LQR) and pole-placement. On the other hand, fuzzy logic and nonholonomic are categorized as non linear control systems.

Ong Yin Chee and Mohamad Shukri b. Zainal Abidin from Universiti Teknologi Malaysia who had undertake the research on design and development of two wheeled autonomous balancing robot .The information on current position and tilt angle of the robot are acquired from the distance measuring sensors (Sharp GP2D12) mounted on an aluminum strip placed at the front and back of the robot. Hence, the analog voltage output from the sensor will converted into digital value via A/D converter of microcontroller then inputs it into PID control algorithm to determine the speed and direction of the motors. Finally, the robot could stand it upright in stable condition and able to be navigated by RC remote control. In brief, these sensors are used to detect the current position and tilting angle of the mobile robot [7].

Rich Chi Ooi who undergoes research on balancing a two-wheeled autonomous robot described on how the PID

controller working for the trajectory control. The PID controller is useful as it will ensure that the position errors between the wheels are minimized, so that the robot will move in a straight path. However, the PID controller used a set of tuning rules which is based on the Ziegler-Nichols method. The encoder reading difference is passed through the PID loop to obtain the required feedback to be added to the motor controller [8].

III. METHODOLOGY

The aim of this project is to apply dual mode navigation function on the robot via the application of wireless PS2 controller and auto navigation mode. In brief, the analog GP2D120 infrared distance sensors work as feedback input for the control algorithm illustrated in Fig 1 which responsible to achieve the stability of the entire system shown in Fig. 2 As such, the control algorithm programmed in the Brain Board will send a signal to the Balance Board for further action once changes on tilt angle and velocity are detected.

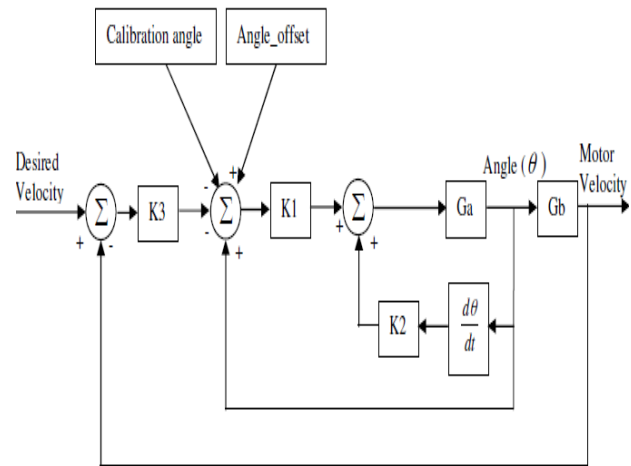

Fig. 1 Digital Cascade Control Loop for Robot

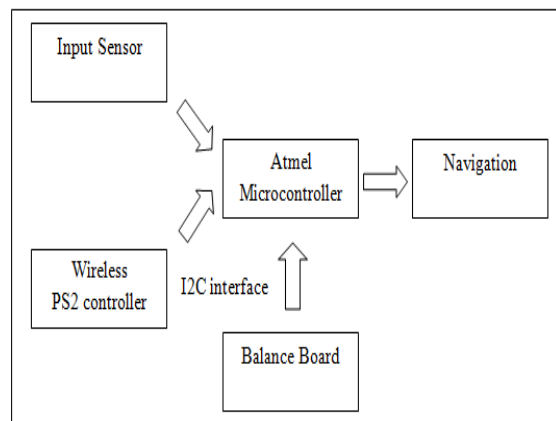

Fig. 2 Block Diagram of Robot System

An external system of microcontroller in the Brain Board will be connected to the Balance Board expansion connector in order to control the Balance Board and to receive sensory

information from the Balance Board. However, the data is exchanged over the I2C bus. The BPC equipped in the Balance Board would act as an I2C slave. In order to communicate with it, a separate microcontroller on the other hand would act as an I2C master. The microcontroller will initiate I2C by reading commands to receive data, and I2C will then write commands to transmit data to the BPC. While writing data, the master should always write 10 bytes and it always read 18 bytes while reading data.



Fig. 3 Robot's Front View

A. Balancing System

The GP2D120 infrared distance sensors work as the dual ground sensor are utilized in the robot to acquire the necessary data of tilt angle and angular velocity crucially required to drive the two DC motors in a manner that keep the center of gravity above the wheels all the times. The Balance Board executes the standard Digital Cascaded Control Loop algorithm which built into Balance Processor Chip to keep the robot balance. The control loop runs at a frequency of approximately 40.2 Hz or delay of 0.025 s.

The control algorithm plays an important role in keeping the two-wheeled robot dynamically stable and able to stand upright on flat terrain. Since the robot worked under mode 0 and 1, therefore the gains of K1, K2 and K3 can only be read and modification is not allowed. The K3 gain is responsible to the varied of the velocity of the mobile robot. Meanwhile, the K1 and K2 gains will responsible to the changes of the tilt angle. The output angle will be measured and compared to the desired angle, Calibration angle. By then, appropriate Angle_offset or error will be added to ensure that the output angle similar to the calibration angle.

In a nutshell, the BPC will function to detect the changes of velocity via Back-Electromotive Force (BEMP). The error between the desired velocity and the measured output velocity will be calculated by the BPC. By considering the tilt angle that feedback from the infrared distance sensors, the mobile

robot will accelerate in the direction that the upper part falling shown in the Fig. 3 In this condition, the two-wheeled robot will remain stable as both the values of two infrared distance sensors are the same

B. Navigation System

The navigation system of the two-wheeled robot is performed by the wireless PS2 controller as shown in the Fig. 4. However, the major problems dealing with this application may include of difficulties to obtain the suitable connector socket for PS2 which is unique and difficult to source as well as require well understanding in the protocol to communicate with it. Apart from that, the process of implementing the PS2 controller protocol to acquire the status (digital and analog) of each button and analog joystick are troublesome and time consuming.



Fig. 4 Wireless PS2 Controller with Receiver

An addition circuit of PS2 I/O converter, PSC28A shown in the Fig. 5 is introduced to help to solve the problems mentioned above. More importantly, it offers a standard connector socket for PS2 controller to plug-in and we can opt to interfacing with or without the microcontroller. Briefly to say that it provides fast and simple way to use the joystick as the input of each button would be converted directly into an output and yet its design is compact, reliable and low cost.

Instead, PSC28A does not only convert the buttons and joystick information on PS2 controller into open collector output with 14 open collector output for 14 buttons, four PWM output for four joystick axis and eight open collector output for 8 joystick directions. Instead, there are also two inputs to control the vibrator motor on the wireless PS2 controller. However, the product specifications and limitations for PSC28A are shown in Table I.

TABLE I
ABSOLUTE MAXIMUM RATING FOR Psc28A

Parameter	Min	Typical	Max	Unit
Input voltage	7	12	15	V
PWR Out	-	Input voltage – 0.7	-	V
Current consumption	-	100	300	mA

The designing of position control or navigation system for the two-wheeled balancing robot using wireless PS2 controller is presented in Table 2. In brief, there are four status for the

IV. RESULT AND DISCUSSION

In this section, the result and observation on the robot in terms of auto and wireless modes will be discussed. Instead, this project is divided into two stages: testing stage and implementation stage which will be explained as well.

A. Auto Navigation Mode

The system is considered stable as both the two analog GP2D120 infrared distance sensors having the same values. As for that, the values from each distance sensor will be subtracted with each other. Once the subtracted value obtain is not zero, therefore the mobile robot will oscillate in a small angle performed by the Balance Board by sending signal to the DC gear motor to move in direction that the upper part body of robot is falling. The process will be repeated in order to achieve zero subtracted value, so that the mobile robot would always balance and capable to stand upright on the flat terrain. The result for path navigation in auto mode is as shown in Fig. 8.

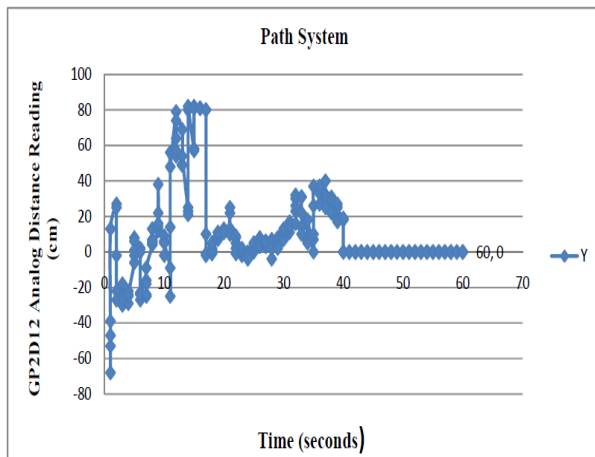

Fig. 8 GP2D120 Distance Reading for Path Navigation

B. Wireless Mode

The wireless PS2 controller which is considered an improved RF device with 2.4 GHz of transmission works greatly within the distance of four meters. However, the mobile robot would always try to balance itself first before performing the navigation instruction. The four buttons of the wireless PS2 controller that will be used for this project are Up, Down, Left and Right buttons. However, these pins of the PSC28A will be connected to the PORT A of PA4, PA5, PA6 and PA7 of the ATMEGA32 microcontroller via connect them to the Digital/Analog inputs of the Brain Board. However, bear in mind that both the PSC28A and Brain Board must be shared a common grounding. Below are the steps to communicate between the two-wheeled balancing robot and the wireless PS2 controller:

i. Before the two-wheeled mobile robot is started to navigate, calibration procedure must be carried out in order it will be stable when the power supply is on. It is done by

putting it on a flat terrain for a few seconds and calibrate under balancing mode.

ii. The PSC28A device is turned on and the Rx LED of the wireless PS2 receiver will start blinking indicates it started to search for the PS2 controller. While the power of the wireless PS2 controller is being turned on, the Rx LED of the receiver will become static indicates the PSC28A device is communicating with the wireless PS2 controller.

iii. Followed by turn on the power supply of the two-wheeled balancing robot. Switch the mode from balancing mode into explore mode for navigation purposes.

iv. The mobile robot can be wirelessly navigated through the wireless PS2 controller by pressing the Up, Down, Left and Right button.

V. CONCLUSION

In a conclusion, this project has been successfully applying dual mode navigation system over the two-wheeled mobile robot with having the capabilities to balance itself on the flat terrain. In brief, problems should be detected in the earlier stage, so that the interfacing between software and hardware would become much easy to implement. Indeed, the two-wheeled robot responds greatly on the wireless PS2 controller's button pressed. As such, this project can be furthered modified with utilizing vibrator motor and GP2D12 infrared distance sensor to notify the user not to move forward as obstacles are detected.

ACKNOWLEDGMENT

The authors gratefully acknowledged the contributions of S.W Nawawi and Z. Hannan for work on the original version of this document.

REFERENCES

- [1] Grasser, F., D'Arrigo, S., Colombi, and Rufer, A. Joe: A mobile Inverted Pendulum. Proceedings of the 2002 IEEE Trans. Electronics. Vol.49, no 1. February. Lausanne, Switzerland: IEEE, 2002. 107-104
- [2] nBot Balancing Robot. Available at: <http://www.geology.smu.edu/~dpa-www/robo/nbot/>
- [3] 17ndJAN2003, steve's LegwayURL <http://www.teamhassenplug.org/robots/legway/>
- [4] Miller Peter (2008), "Building a Two Wheeled Balancing Robot", University of Southern Queensland, Faculty of Engineering and Surveying. Retrieved Nov 18, 2009. Available at: <http://eprints.usq.edu.au/6168/>
- [5] Zatil Hanan Binti Ahmad Lutpi (2009). Position Control of Two Wheeled Inverted Pendulum. Universiti Teknologi Malaysia: Thesis B. Electrical Engineering (Control & Instrumentation)
- [6] Herdawatie binti Abdul Kadir (Nov 2005). Modelling and Control of a Balancing Robot using Digital State Space Approach, Master Thesis, Universiti Teknologi Malaysia
- [7] Ong, Yin Chee; Abidin, M.S.B (2006). "Design and Development of Two Wheeled Autonomous Balancing Robot", Center for Artificial Intell. & Robotic (CAIRO), University Technology Malaysia, Kuala Lumpur. 4th Student Conference on Research and Development (SCORED 2006), Shah Alam, Selangor, MALAYSIA, 27-28 June, 2006.
- [8] Ooi, Rich Chi (2003). "Balancing a Two-Wheeled Autonomous Robot". University of Western Australia. Thesis B. Mechatronics Engineering.