

Double Flux Orientation Control for a Doubly Fed Induction Machine

A. Ourici

Abstract—Doubly fed induction machines DFIM are used mainly for wind energy conversion in MW power plants. This paper presents a new strategy of field oriented control, it is based on the principle of a double flux orientation of stator and rotor at the same time. Therefore, the orthogonality created between the two oriented fluxes, which must be strictly observed, leads to generate a linear and decoupled control with an optimal torque. The obtained simulation results show the feasibility and the effectiveness of the suggested method.

Keywords—Doubly fed induction machine, double flux orientation control, vector control, PWM inverter.

I. INTRODUCTION

IN order to meet power needs, taking into account economical and environmental factors, wind energy conversion is gradually gaining interest as a suitable source of renewable energy. The electromagnetic conversion is usually achieved by induction machines or synchronous and permanent magnet generators. Squirrel cage induction generators are widely used because of their lower cost, reliability, construction and simplicity of maintenance [1]. But when it is directly connected to a power network, which imposes the frequency, the speed must be set to a constant value by a mechanical device on the wind turbine. Then, for a high value of wind speed, the totality of the theoretical power can not be extracted. To overcome this problem, a converter, which must be dimensioned for the totality of the power exchanged, can be placed between the stator and the network. In order to enable variable speed operations with a lower rated power converter. The DFIM has some distinct advantages compared to the conventional squirrel-cage machine. The DFIM can be controlled from the stator or rotor by various possible combinations. The disadvantage of two used converters for stator and rotor supplying can be compensated by the best control performances of the powered systems [2]. Indeed, the input-commands are done by means of four precise degrees of control freedom relatively to the squirrel cage induction machine where its control appears quite simpler. The flux orientation strategy can transform the non linear and coupled DFIM-mathematical model to a linear model leading to one attractive solution as well as under generating or motoring operations [3–4].

Because both stator and rotor currents in doubly fed induction machine are measurable, flux vectors can be calculated easily. We present in this paper a field orientation control for both stator and rotor fluxes. It results that the stator flux oriented in

q-axis becomes the active power input command from which the developed torque will be controlled, while the rotor flux assumes the reactive power input command acting the magnetizing machine system.

II. DESCRIPTION AND MODELLING OF DFIM

The proposed system is shown on figure 1, it is constituted by two pulse width modulation inverters supplying separately the stator and the rotor of the machine [5].

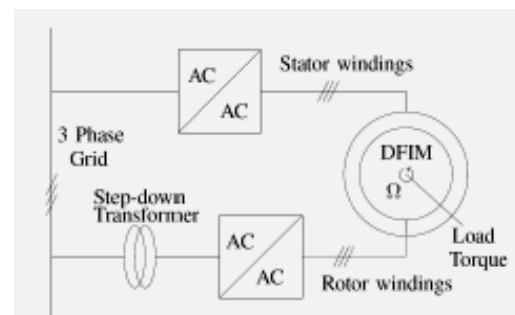

Fig. 1 DFIM supplied by two PWM inverters

We choose three levels PWM for both stator and rotor inverters, it is constituted of three arms, every one has four switches formed by a transistor and a diode as shown in fig. 2.

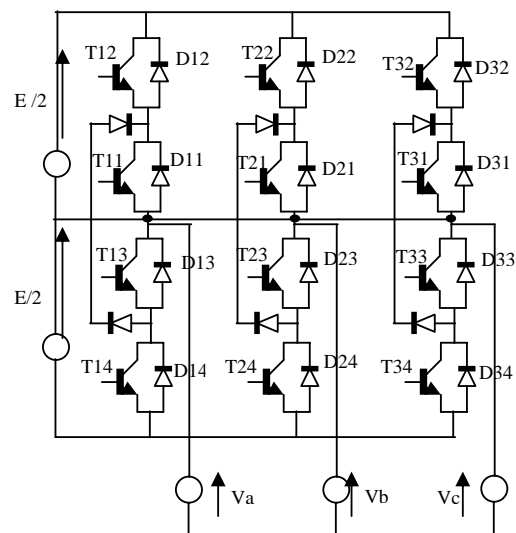

Fig. 2 General diagram of a three level PWM inverter.

The simple voltages are obtained starting from the following conditions:

A. Ourici is now with electrical engineering institute of Badji Mokhtar University of annaba Algeria; a_ourici@hotmail.com

If $(V_{ref} = V_p)$ and $(V_{ref} > 0)$

$$\Rightarrow V_K = +E/2$$

If $(V_{ref} = V_p)$ and $(V_{ref} < 0)$

$$\Rightarrow V_K = -E/2$$

If $V_{ref} = V_p \Rightarrow V_K = 0$

With

V_{ref} : reference voltage standard;

V_p : carrying;

V_K : potential of the node K.

$$\begin{cases} \psi_{ds} = L_s I_{ds} = M I_{dr} \\ \psi_{qs} = L_s I_{qs} + M I_{qr} \\ \psi_{dr} = L_r I_{dr} + M I_{ds} \\ \psi_{qr} = L_r I_{qr} + M I_{qs} \end{cases} \quad (3)$$

Mechanic equation is given by:

$$C_{em} = Cr + J \frac{d\Omega}{dt} + f\Omega \quad (4)$$

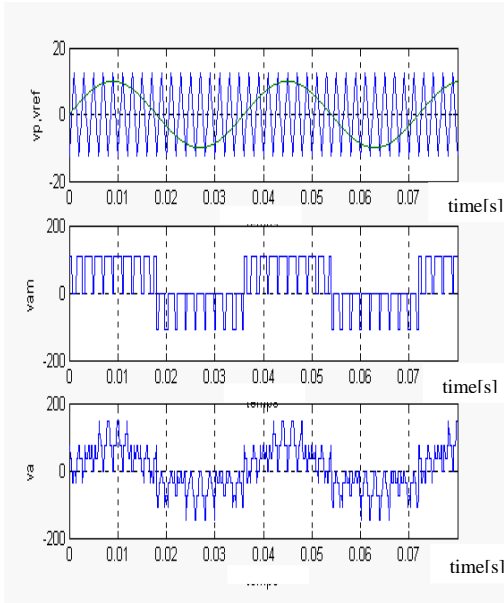

Fig. 3 Carrying voltage, simple voltage and phase voltage.

Stator and rotor voltages of the machine after Park transformation are given by [6]:

$$\begin{cases} V_{ds} = R_s I_{ds} + \frac{d}{dt} \psi_{ds} - \frac{d\theta_s}{dt} \psi_{qs} \\ V_{qs} = R_s I_{qs} + \frac{d}{dt} \psi_{qs} + \frac{d\theta_s}{dt} \psi_{ds} \end{cases} \quad (1)$$

$$\begin{cases} V_{dr} = R_r I_{dr} + \frac{d}{dt} \psi_{dr} - \frac{d\theta_r}{dt} \psi_{qr} \\ V_{qr} = R_r I_{qr} + \frac{d}{dt} \psi_{qr} + \frac{d\theta_r}{dt} \psi_{dr} \end{cases} \quad (2)$$

Stator and rotor fluxes are given by:

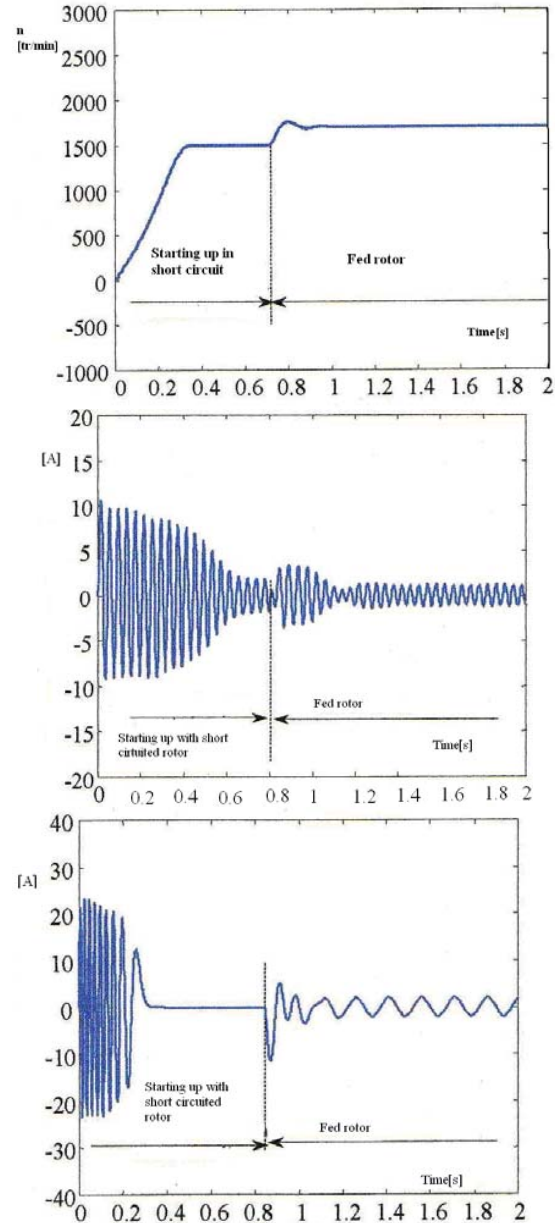

Fig. 4 Speed, stator current and rotor current during starting up of the machine.

II . DOUBLE FLUX ORIENTATION STRATEGY

This strategy consists to turn rotor flux towards d-axis, and stator flux towards q-axis. Conventionally, the d-axis remains reserved to magnetizing axis and q -axis to torque axis.

$$\begin{aligned} \psi_{sq} &= \psi_s , \\ \psi_{rd} &= \psi_r , \\ \psi_{sd} &= \psi_{rq} = 0 . \end{aligned}$$

Then the developed torque can be written like this

$$C_{em} = Dc\psi_s\psi_r , Dc = pM/\sigma L_s L_r$$

Vectoriel diagrams before and after flux orientation are shown as follows [7]

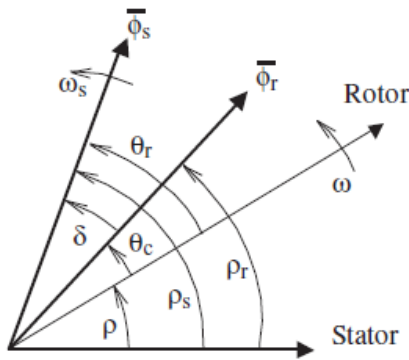

Fig .5 DFIM flux relative armature position

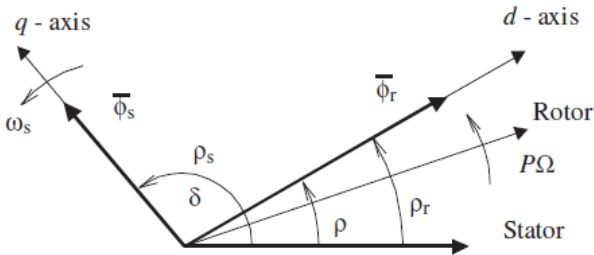

Fig .6 DFIM vectorial diagram after orientation

III. RESULTS ANALYSIS

Fig. 3 shows the carrying voltage, simple voltage and phase voltage of the three levels inverters used. Figure 4 presents speed, stator current and rotor current in the starting up of the machine ,until 0.8s the machine starts with rotor in short circuit, after the rotor is fed by the inverter. In figure 5 we can see speed, electromagnetic torque and stator and rotor fluxes after flux orientation. It can be said that this strategy in addition of its simplicity, shows good results.

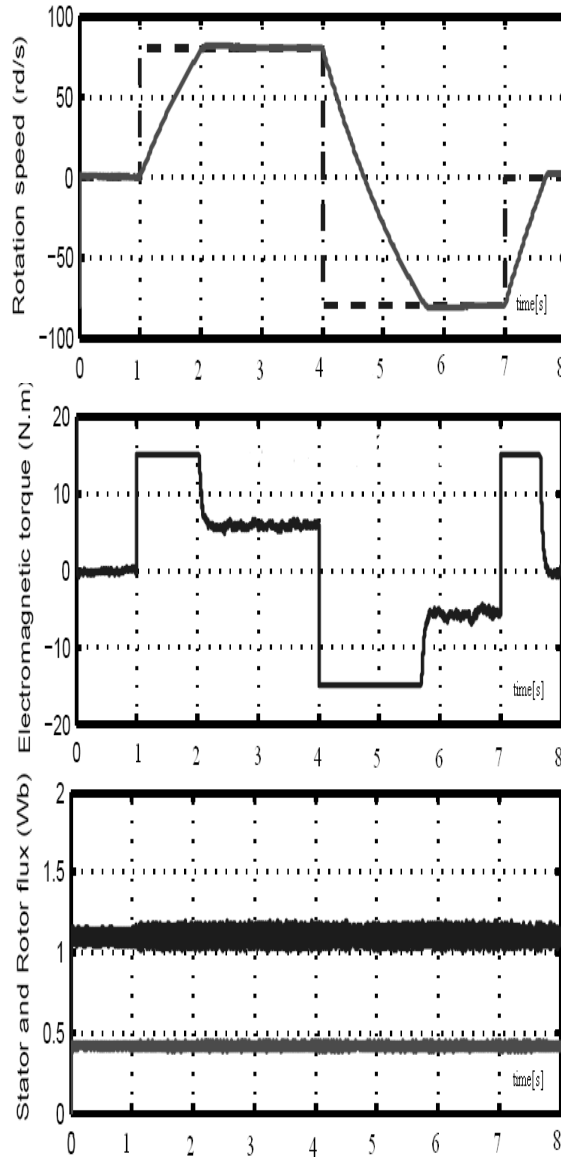

Fig .5 Speed, electromagnetic torque and stator and rotor fluxes

IV. CONCLUSION

We present in this paper a simulation of a doubly fed induction machine fed with two pulse width modulation inverters , based on d-q modeling. Access to the stator and rotor windings is one of the advantages of the wound rotor induction machine compared to the conventional squirrel-cage machine, consequently the doubly fed induction machine offer the several possible combinations for its control. A double flux orientation was presented , Since the fluxes are used like control variables, the machine fluxes must be maintained at acceptable level especially during the transient regimes. This strategy of control permits to give an optimal developed torque.

REFERENCES

- [1] S. Heier, "Grid integration of wind energy conversion systems.", John Wiley & Sons Ltd, England, 1998.
- [2] Debiprasad Panda, Benedict, E. L., Venkatara- Manan, G., Lipo, T. A. : A novel control strategy for the rotor side control of a doubly-fed induction machine, IEEE (2001), 1695–1702.
- [3] Vicatos, M. S., Tegopoulos, J. A. : A doubly-fed induction machine differential drive model for automobiles, IEEE Transactions on Energy Conversion, 18 No. 2 (2003), 225–230.
- [4] Peresada, S., Tilli, A., Tonielli, A. : Indirect stator flux-oriented output feedback control of a doubly fed induction machine, IEEE Trans. On Control Systems Technology 11, (2003), 875–888.
- [5] F. Bonnet, P E Vidal and M Pietrzak-David, "Direct control of doubly fed induction machine", Bulletin of the polish academy of sciences, Technical sciences , Vol 54, N°3, 2006.
- [6] Paul Etienne VIDAL, "Commande non linéaire d'une machine asynchrone à double alimentation", Thesis of doctorate, Toulouse France, December 2004.
- [7] S. Drid, M. Tadjine, M.S. Nait Said, "Nonlinear feedback control and torque optimisation of a doubly fed induction motor", Journal of electrical engineering, vol 56, N° 3-4, pp 57-63, 2005.

A. Ourici was born in Annaba, Algeria, in 1973, she obtains a mathematic Baccalaureate in 1990 after she obtains the engineer degree in 1995, the M.S degree in 1998, and PhD in electrical engineering in 2007, Her major field of research is modeling and simulation of AC machines.