

# Development of Transmission Line Sleeve Inspection Robot

Jae-Kyung Lee, Nam-Joon Jung, Byung-Hak Cho

**Abstract**—The line sleeves on power transmission line connects two conductors while the transmission line is constructing. However, the line sleeves sometimes cause transmission line break down, because the line sleeves are deteriorated and decayed by acid rain. When the transmission line is broken, the economical loss is huge. Therefore the line sleeves on power transmission lines should be inspected periodically to prevent power failure. In this paper, Korea Electric Power Research Institute reviewed several robots to inspect line status and proposes a robot to inspect line sleeve by measuring magnetic field on line sleeve. The developed inspection tool can reliable to move along transmission line and overcome several obstacles on transmission line. The developed system is also applied on power transmission line and verified the efficiency of the robot.

**Keywords**—Transmission line inspection, line sleeve, transmission line inspection robot, line sleeve inspection

## I. INTRODUCTION

LINE sleeves, which are usually used to connect LACSR(Aluminum Conductor Steel Reinforced) cables when the lines were constructing, are consist of Aluminum sleeve, which connect the conductor parts, and steel sleeve, which used to uphold tension on cables.

However, the connected transmission line frequently breaks down due to sleeve deterioration and corrosion, and accordingly wire replacement cost is expected to increase continuously. However, inspecting line sleeves to detect faulty and deteriorated line sleeve on operating transmission line always exist working safety concerning. Moreover, the existing inspection equipment has large error and poor accuracy to determine whether a line sleeve is healthy.

Recently, because of wildfires due to worldwide climate change and acid rain due to air polluted, sleeve deterioration is highly accelerated. The line sleeve rapidly deteriorates once the initial symptoms happen, however, the initial symptoms are not able to detect with infrared thermal camera on ground or air. Therefore, needs for developing line sleeve inspection equipment development is getting increase.

Compare with the importance of line sleeve, current sleeve inspection technology is too crude. Some foreign power companies drill a hole to inspect line sleeve. To inspect

Joon-Young Park is with Korea Electric Power Research Institute, Munjiro 65, Yuseong-gu, Daejeon, 305-380, Korea (phone: 82-42-865- 5373; fax: 82-42-865-5202; e-mail: asura@kepco.co.kr).

Jae-Kyung Lee is with Korea Electric Power Research Institute, Munjiro 65, Yuseong-gu, Daejeon, 305-380, Korea (e-mail: jklee78@kepco.co.kr).

Ki-Yong Oh is with Korea Electric Power Research Institute, Munjiro 65, Yuseong-gu, Daejeon, 305-380, Korea (e-mail: okyer@kepri.re.kr).

Jun-Shin Lee is with Korea Electric Power Research Institute, Munjiro 65, Yuseong-gu, Daejeon, 305-380, Korea (e-mail: ljs@kepri.re.kr).

transmission line, Canada's Hydro – Québec has been developing LineScout Technology since 2000 and applied the robot on 735kV transmission line[1-4]. The Kansai power company in Japan also developed Hibot to monitor transmission line state[5].

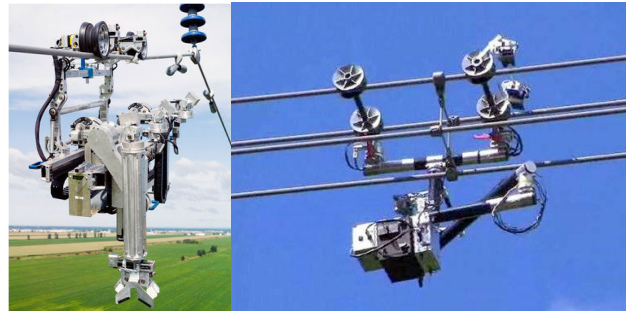

(a) LineScout

(b) HiBot



(c) Domestic line sleeve inspect method

Fig. 1 Line sleeve inspect

In Korea, to prevent transmission line failures to secure power transmission reliability, KEPCO built “Reference for transmission line operation(2010.02.01)[6]” and manages eccentric degree of line sleeves by the means of measuring Mr. Young or thermal infrared camera. But, both way commonly unreliable in the aspect of accuracy, squandering money and safety of transmission line operators. Especially, Mr. Young has  $\pm 25\text{mm}$  error and the error changes by operator.

This paper describes a process for developing a system to measuring line sleeve eccentric degree while the operators stay in remote area. The developed system minimizes error of line sleeve and maximizes the accuracy while measuring eccentric degree. The system also diagnosis fault line sleeve in remote area to secure the operator's safety.

II. LINE SLEEVE DETERIORATION AND INSPECTION ENVIRONMENT

A. Deterioration of Line Sleeve

Deterioration of line sleeve usually caused by large current which flows steel sleeve in line sleeve. Usually, current on transmission line flows along the ACSR conduit. However, current usually transmitted in steel sleeve on eccentric line sleeve, which might cause a huge amount of heat on steel sleeve[7].

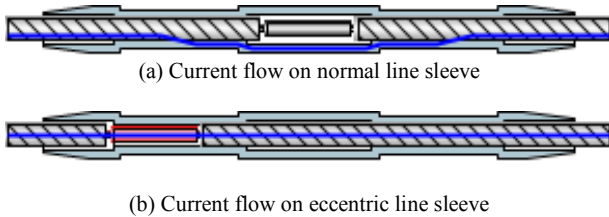

Fig. 2 Line Sleeve current flow and broken sleeve

Especially, eccentric line sleeve is not detected using thermal infrared camera and invisible, non-destructive inspection method required to find eccentric line sleeve.

B. Operational Environment Analysis

ACSR cables are usually used while constructing transmission line. ACSR240, ACSR330, ACSR410, ACSR 480R, ACSR480C are used for 154KV Transmission Line. And ACSR480R, ACSR480C also used on 345KV transmission line. Table. 1 shows specification of transmission line cables.

In addition, several kinds of obstacles are mounted on the transmission line, the developing system should bring the inspection tool to line sleeve by overcoming those obstacles.

TABLE I  
SPECIFICATION OF TRANSMISSION LINE CABLES

mm <sup>2</sup> Cable Type	95	160	240	330	410	480R	480C	520
ACSR	13.5	18.2	22.4	25.3	28.5	29.6	30.4	31.5
HACSR	13.5	18.2	22.4	25.3	28.5	29.6	30.4	31.5
TASCR	13.5	18.2	22.4	25.3	28.5	29.6	30.4	31.5
HTACSR	13.5	18.2	22.4	25.3	28.5	29.6	30.4	31.5
ACSR/AW	13.5	18.2	22.4	25.3	28.5	29.6	30.4	31.5

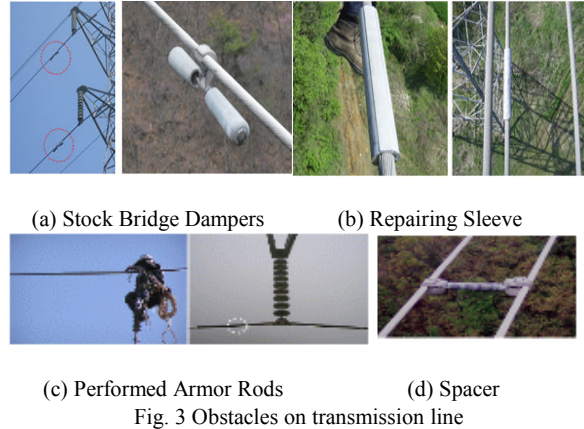

To prevent transmission line from breaking down, S.B.(Stock Bridge) Damper is attached. In addition, repairing sleeves are used when transmission line was damaged, which makes transmission line bigger about 61%~70% than others. Also, Armor Rods are used to prevent ACSR cable from being damaged around insulator string. Spacer also used between conduits not to be twisted and collide between different phases.

III. LINE SLEEVE INSPECTION DEVICE

A. Design of Line Sleeve Inspection Tool Mechanical Parts

Line sleeve inspection tool consist of two parts, moving part and inspection part. Moving part delivers the inspection part to line sleeve and overcomes the obstacles along transmission line. On the other hand, magnates and hall sensor and encoder are mounted on the inspection part to measure eccentricity of line sleeve.

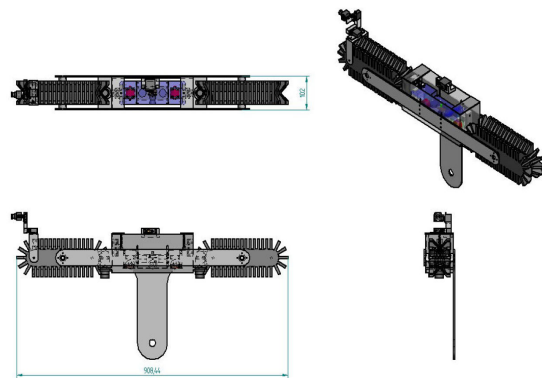

Moving part overcomes obstacles, such as S.B. Damper and Spacer, along transmission line and delivers the inspection part toward line sleeve. Two caterpillar mechanisms have adapted on the moving part to deal with rapid gradient on transmission line and move along the transmission line without being fallen even though some obstacles are exists. Figure 5 shows caterpillar adapted on the moving part.

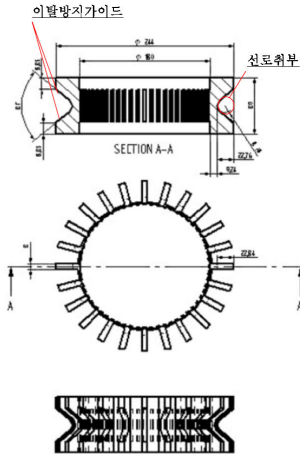

Fig. 5 Caterpillar adapted on moving part

Caterpillar has a hardness of 15 to Urethane and the center of caterpillar has two forms of circular grooves. The inner groove rules as to grip ACSR cables and the outer groove rules to prevent the robot from being deviated from cable by maximizing friction force between cable and caterpillar. Two moving parts are connected via inspection part and interconnection part was designed unbalanced to avoid Spacer and S.B. Damper.

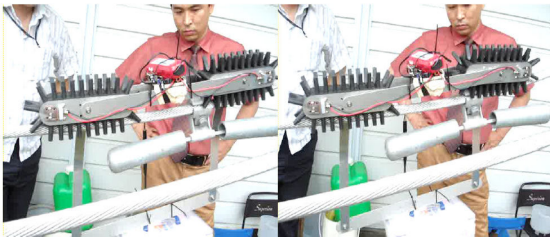

Fig. 6 Overcome S.B. Damper using two Caterpillars



Fig. 7 Overcome Spacer using two caterpillars

Inspection module of sleeve inspection tool measures steel sleeve position in line sleeve. Inspection module has two magnets, one hall sensor, one encoder roller and servo motor.

Inspection part consists of Permanent magnets, Hall sensor and magnet circuit to detect magnetic flex which penetrates steel sleeve cross section. Also, encoder is attached to measure distance from line sleeve reference coordinate. Measured intensity of magnetic flex transmitted to remote controller to calculate eccentricity of sleeve.

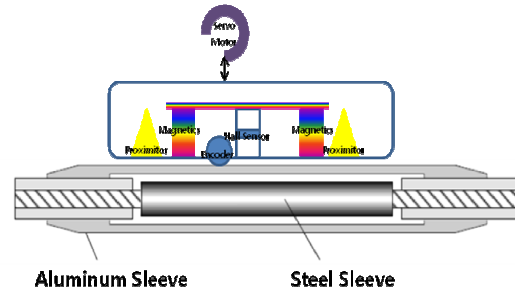

Fig. 8 Components diagram of inspection part

The hall sensor installed underneath of the module to capture maximum magnetic flux. The scanning process performed twice on each line sleeve to verify accuracy. Except measuring magnetic flux, proximity sensors are mounted to recognize the end of line sleeve and roller to move smoothly over the sleeve. Servo motor also designed to lift up and down while inspection procedure. 3 leds are displaying the status of inspection robot.

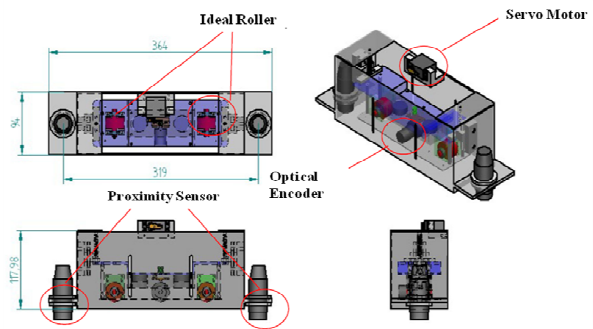

Fig. 9 Design of inspection part

One urethane roller on the inspection part connected to encoder to measure position of steel sleeve and ends of steel sleeve. Two flex generating magnet and one hall sensor closely adhered on the surface of line sleeve and the roller prevent the inspection from vibrating and uphold the inspection part while inspecting.



Fig. 10 Mechanical part of line sleeve inspection tool

## B. Model of line sleeve inspection tool

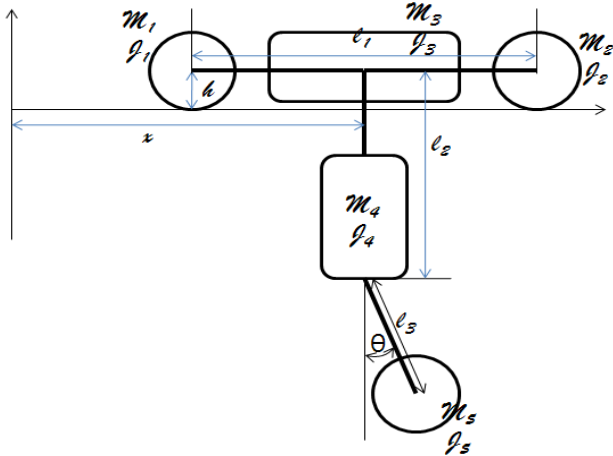

Fig. 11 Free body diagram of line sleeve inspection system

To control line sleeve inspection tool, dynamic model of the tool was built using Lagrange's method. Fig. 11 shows free body diagram of dynamic model. All rigid body are assumed as point mass to simplify the model.

As a reference moving axis, transmission line is selected x-axis and 'x' is distance from reference point to center of inspection tool. Mass and inertia of each part are denoted as  $m_1$ ,  $m_2$  (caterpillar),  $m_3$  (inspection part),  $m_4$  (controller),  $m_5$  (weight balance) and  $J_1, J_2, J_3, J_4, J_5$ .  $l_1$  stands for distance between caterpillar and  $l_2$  means distance between reference of weight balance and center of inspection module.

When the inspection tool moves toward line sleeve, the moving parts are  $m_1, m_2, m_3, m_4$  and distance vector  $\hat{r}_{M_3}$  can be described using distance  $x$  and height  $h$ . Also position vector of weight balance  $\hat{r}_{M_5}$  can be described as below.

$$\hat{r}_{M_3} = x\hat{i} + h\hat{j}$$

$$\hat{r}_{M_5} = (x + l_3 \sin \theta)\hat{i} + (l_2 - h + l_3 \cos \theta)\hat{j}$$

The velocity vector is described as below

$$\hat{v}_{M_3} = \dot{x}\hat{i}$$

$$\hat{v}_{M_5} = (\dot{x} + \dot{\theta} l_3 \cos \theta)\hat{i} + \dot{\theta} l_3 \sin \theta \hat{j}$$

By using LaGrange's equation, dynamic model of the inspection tool can be driven.

$$\begin{bmatrix} \ddot{x} \\ \ddot{\theta} \end{bmatrix} = [A]^{-1} * \left\{ -[B] \begin{bmatrix} \dot{x} \\ \dot{\theta} \end{bmatrix} - [C] + [D] \right\}$$

$$A = \begin{bmatrix} (M_1 + M_2 + M_3 + M_4 + \frac{1}{h}(J_1 + J_2) + M_5) & M_3 l_3 \cos \theta \\ M_3 l_3 \cos \theta & J_{M_5} + M_5 l_3^2 \end{bmatrix}$$

$$B = \begin{bmatrix} 0 & \dot{\theta} l_3 \sin \theta \\ 0 & 0 \end{bmatrix} \quad C = \begin{bmatrix} 0 \\ -gM_5 l_3 \sin \theta \end{bmatrix} \quad D = \begin{bmatrix} F_x - \dot{x}f_x \\ F_\theta - \dot{\theta}f_\theta \end{bmatrix}$$

## C. Control system and user interface of inspection tool

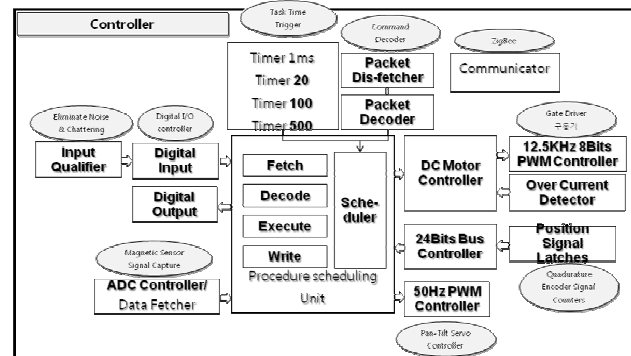

Fig. 12 Software diagram of remote inspection system

Control software of remote system drives each modules of inspection system and controls overall system. Control task performed on one microprocessor. Mainly the controller performs timer task to do regular control works such as motor control and input check. Digital input module has input qualifier to cancel chattering noise. Distance based ADC (Analog Digital Converter) acquires magnetic flex intensity in every 1mm to decide how far the center is eccentric from center of line sleeve. Also, the microcontroller captures encoder signal and controls servo motor to lift up and down inspection module. Fig. 12 shows software diagram of remote inspection system.

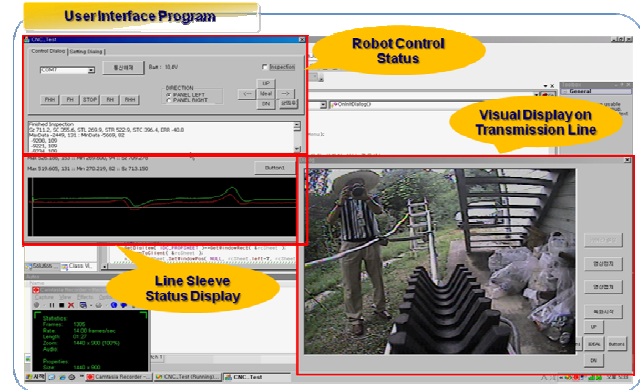

Fig. 13 User interface program

Fig. 13 shows user interface program. User interface program shows status of inspection tool and input user command such as move forward, backward, and communication control. Also Line sleeve eccentric degree is calculated and displayed on user interface program to determine whether line sleeve is eccentric.

## IV. LINE SLEEVE INSPECTION DEVICE

Using developed system, actual line test performed on Sin-Okcheon substation. Single and dual line test had performed to verify obstacle overcomes. Accuracy performance test also performed with sample test line.

Line test had performed on 20<sup>th</sup> Aug. 2010 on dual transmission line and the angle of dual line was more than 45° because of weight of inspection device. Moreover, the angle of

dual line was precipitous when the device moves toward the center of tower span. So, the device had failed to overcome S.B.Damper on dual line whereas the device had succeeded to overcome obstacles on single line.

camera attached to inspect transmission line conditions. However, newly developed system is not possible to inspect dual line transmission line cause of balance. Therefore, certain modifications are required to adapt the system on dual line.



(a) Dual line test (b) Single line test  
Fig. 14 Actual line test on Sin-Okcheon Substation

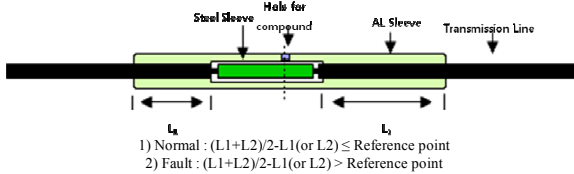
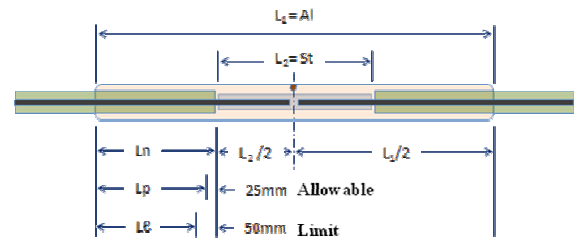

Fig. 15 Reference of normal & faulty line sleeve



	$L_1/Al$	$L_2/5t$	$L_n/Normal$	$L_p/Allowable$	$L_k/Limit$
J-8	640	200	220	185	170
J-9	740	240	250	225	200
J-13	710	240	235	210	185

Fig. 16 Conditions for test sleeves

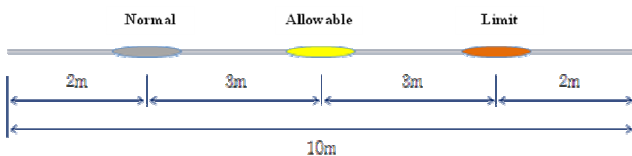

Fig. 17 Installation of test sleeves

Fig. 16 shows result of performance test and compared the result with Mr. Young. In same condition, ACSR330 mm<sup>2</sup>, ACSR410mm<sup>2</sup>, and ACSR480mm<sup>2</sup>(R), three types of sleeves has manufactured in normal, allowable, limit condition. Mr. Young has 11.63mm deviation with 135 tests, and 3.66 deviations with newly developed device to inspect line sleeve in 55 tests

V.CONCLUSION

Newly developed line sleeve inspection system has developed with caterpillar mechanism and magnetic circuit. The developed system overcomes several obstacles on transmission line to inspect line sleeve on transmission line. Also, wireless

REFERENCES

- [1] Montambault, S., Pouliot, N., "LineScout technology: Development of an inspection robot capable of clearing obstacles while operating on a live line," Transmission & Distribution Construction, Operation and Live-Line Maintenance, ESMO 2006. IEEE 11th International Conference on, Oct., 2006
- [2] Pouliot, N., Montambault, S., " Geometric design of the LineScout, a teleoperated robot for power line inspection and maintenance," Robotics and Automation, 2008. ICRA 2008. IEEE International Conference on, 19-23 May 2008
- [3] Pouliot, N., Montambault, S., "LineScout technology: From inspection to robotic maintenance on live transmission power lines," Robotics and Automation, 2009. ICRA '09. IEEE International Conference on, 12-17 May 2009.
- [4] Toth, J., Pouliot, N., Montambault, S., "Field experiences using LineScout Technology on large BC transmission crossings," Applied Robotics for the Power Industry (CARPI), 2010 1st International Conference on, 5-7 Oct. 2010.
- [5] Debenest, P., Guarnieri, M., Takita, K., Fukushima, E.F., Hirose, S., Tamura, K., Kimura, A., Kubokawa, H., Iwama, N., Shiga, F., "Expliner - Robot for inspection of transmission lines," Robotics and Automation, 2008. ICRA 2008. IEEE International Conference on, 19-23 May 2008.
- [6] W-. J. Kim, "Reference for transmission line maintenance, " KEPCO, 06 Feb. 2007.
- [7] B-. H. Cho, J-. Y. Park, J-. K. Lee, S-. H. Kim, "ACSR Line sleeve Tester", Korea patent 2009-32312, 01 April 2009.