

Development of EPID-based Real time Dose Verification for Dynamic IMRT

Todsaporn Fuangrod¹, Daryl J. O'Connor¹, Boyd MC McCurdy³, Peter B. Greer^{1,2}

Abstract—An electronic portal image device (EPID) has become a method of patient-specific IMRT dose verification for radiotherapy. Research studies have focused on pre and post-treatment verification, however, there are currently no interventional procedures using EPID dosimetry that measure the dose in real time as a mechanism to ensure that overdoses do not occur and underdoses are detected as soon as is practically possible. As a result, an EPID-based real time dose verification system for dynamic IMRT was developed and was implemented with MATLAB/Simulink. The EPID image acquisition was set to continuous acquisition mode at 1.4 images per second. The system defined the time constraint gap, or execution gap at the image acquisition time, so that every calculation must be completed before the next image capture is completed. In addition, the γ -evaluation method was used for dose comparison, with two types of comparison processes; individual image and cumulative dose comparison monitored. The outputs of the system are the γ -map, the percent of $\gamma < 1$, and mean- γ versus time, all in real time. Two strategies were used to test the system, including an error detection test and a clinical data test. The system can monitor the actual dose delivery compared with the treatment plan data or previous treatment dose delivery that means a radiation therapist is able to switch off the machine when the error is detected.

Keywords—real-time dose verification, EPID dosimetry, simulation, dynamic IMRT

I. INTRODUCTION

ACCURATELY verifying delivery of ionizing radiation to therapy patients is primary to achieving maximum treatment efficacy. Electronic portal image devices (EPIDs) have been widely investigated as tools for the verification of patient position and dose measurement because of their useful characteristics such as fast image acquisition, high resolution, and digital format. As a result, a considerable number of research studies have focused on EPID dosimetry over the past approximately 20 years [1]. In addition, EPID dosimetry, has become a method of patient-specific IMRT dose verification for radiotherapy [2].

In general, there are two types of radiotherapy quality assurance (QA) and verification procedures; pre and post-treatment verification. Even though QA can be performed

before and after the treatment, unexpected errors could occur during the treatment delivery [3]. For instance, the MLC leaf positions of each segment (control point) could be corrupted [4]. This error is hard to detect with QA procedures because it occurs during transfer of the plan data into the treatment system.

Interestingly, there are currently no interventional procedures using EPID dosimetry that measure the dose in real-time as it is delivered to the patient as a mechanism to ensure that overdoses do not occur and underdoses are detected as soon as is practically possible. In this work, we develop an EPID-based real-time dose verification system for dynamic IMRT by using MATLAB/Simulink (The Mathworks, Natick, MA). The γ -evaluation method as a tool for dose comparison was used. The performance of the system was shown by testing with introduced dose errors and clinical data captured by an EPID during an IMRT delivery.

II. MATERIALS AND METHODS

A. IMRT delivery and image acquisition

The EPID-based real time verification system must perform within the strict response time constraints imposed by the fast image acquisition. A suitable acquisition mode for dynamic IMRT and IMAT has been investigated [5] and it was found that the continuous acquisition mode in EPID performs well compared with time-resolved ion-chamber measurement. In this work, the continuous mode was thus used for capturing a sequence of images in real-time during radiation delivery. Irradiation was performed using 6 MV beams of a Varian Trilogy linear accelerator (Varian Medical System, Palo Alto, CA) equipped with an aS500 EPID with a matrix size of 384X512 pixels. For the testing and simulation, images were acquired using 360 MU irradiations at a nominal dose rate of 600 MU/min in continuous (cine) image acquisition mode with the EPID at 150 cm source-to-detector distance. Image acquisition was controlled by the IAS3 system software.

Within the above configuration, the image acquisition time is approximately 1.4 images per second that means single images were recorded every 0.7 sec. Each image was the average of 5 individual frames. As a result, the system has set a time constraint or execution gap, including read image step, dose comparison step, and output generating step, with no longer than 0.7 sec for each dose comparison. (fig. 1)

1. School of Mathematical and Physical Sciences, University of Newcastle, Newcastle, New South Wales 2308, Australia

2. Department of Radiation Oncology, Calvary Mater Hospital, Newcastle, New South Wales, 2310, Australia

3. Division of Medical Physics, CancerCare Manitoba, 675 McDermott Avenue, Winnipeg, Manitoba R3E 0V9, Canada; Department of Physics and Astronomy, University of Manitoba, Winnipeg, Manitoba R3T 2N2, Canada; and Department of Radiology, University of Manitoba, Winnipeg, Manitoba R3T 2N2, Canada

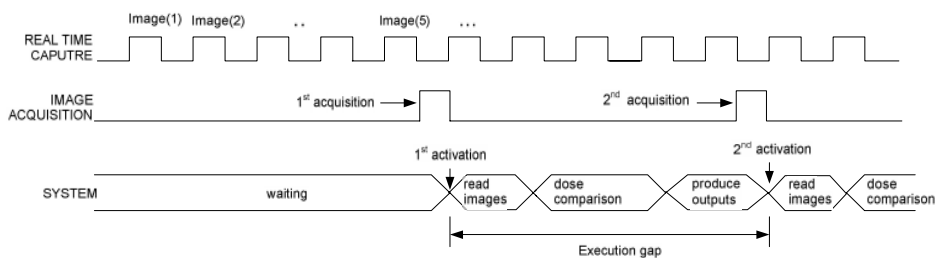

Fig. 1 System-machine interface model and execution gap construction based on image acquisition

B. γ -evaluation method with filtering

A basic technique of EPID dose comparison, called the γ -evaluation method, was introduced by Low et al [6]. This γ -evaluation method is used as a form of dose comparison in a quantitative manner combining dose-difference (DD) and distance-to-agreement (DTA) criteria.

As the γ value is defined for each reference dose point \vec{r}_r as

$$\gamma(\vec{r}_r) = \min\{I(\vec{r}_e, \vec{r}_r)\} \forall \{\vec{r}_e\} \quad (1)$$

where \vec{r}_e refers to the evaluated dose distributions point. The generalized distance is labeled Γ . Γ is the generalized Euclidean distance in the renormalized dose and distance space, where distance and dose axes have been divided by the DTA and DD criteria.

$$\Gamma(\vec{r}_e, \vec{r}_r) = \sqrt{\frac{|\vec{r}_e - \vec{r}_r|^2}{\Delta d^2} + \frac{[D_e(\vec{r}_e) - D_r(\vec{r}_r)]^2}{\Delta D^2}} \quad (2)$$

where $D_e(\vec{r}_e)$ and $D_r(\vec{r}_r)$ are the evaluated and the reference dose distribution, respectively. We use two types of comparison processes; individual image and cumulative dose comparison. The individual dose comparison is to calculate the γ value over the paired reference and evaluated doses correlated in time. In the case of the cumulative comparison the cumulative amount of dose from time 0 to current time T is assessed.

However, the main limitation of the original γ -concept is the speed of calculation. Many research groups have developed methods for improving the speed. For example, Stock et al [7] implemented a software tool with an intelligent search algorithm for boosting the speed of calculation. Jiang et al [8] introduced the concepts of equivalent dose tolerance, maximum allowed dose difference (MADD) and the normalized dose difference (NDD). Instead of the high computation workload to find the γ value, MADD is defined as

the acceptance region for the pass/fail boundary. In this work, we applied a filter function with a global threshold into a pre-processing step that can eliminate low-intensity (dose) in an image for improved speed.

System Design

MATLAB/Simulink is a widely used software tool for designing and simulating models for control applications. The EPID-based real-time dose verification system is represented with the MATLAB/Simulink tool. The system is then merged with the signal processing block set and video and image processing block set, as shown in fig. 3.

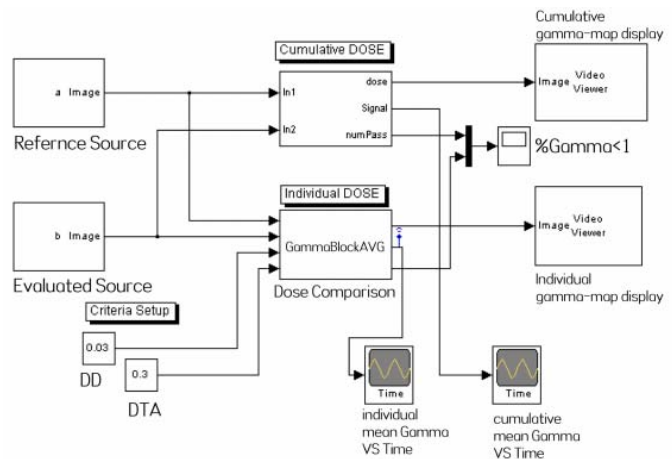

Fig. 2 Designing the EPID-based real-time dose verification model with MATLAB/Simulink

Figure 2 illustrates the model of the system; firstly, the input stage consists of reference data source, evaluated data source, DD and DTA parameters. Secondly, the process stage includes cumulative and individual dose comparison. The output stage displays the γ -map, percent of $\gamma < 1$, and mean- γ versus time. In addition, a user interface is shown in figure 3.

C. System Testing

To analyse the performance of the system, two strategies for testing were used; Error detection test and Clinical data test. For the Error detection test, errors were artificially introduced into a reference data source which then was used as the evaluated data source. Global dose difference errors (+3%, +4%, and +5%) and noise errors ($\pm 3\%$, $\pm 4\%$, and $\pm 5\%$) were

used. The Clinical data test was simulated by using a prostate case treatment and setting the first treatment image as the reference data source and the second treatment as the evaluated data source. The Error detection test aims to test the individual dose comparison method that can detect the dose error during treatment frame-by-frame. However, the simulation technique with clinical data tests the function of the system with real data and can be used to determine error detection thresholds.

III. RESULTS

An example of the γ map, the percent $\gamma < 1$, and mean γ performed during simulation are illustrated in figure 4. In terms of Error detection test, the introduced dose errors were analysed with 3%, 3mm criteria. In addition, 50 EPID images were analysed using the system. As the system must perform within strict constraints on response time, the speed of processing is a major factor. An Intel 2 Duo core 3GHz with 2GB of Ram was used in this simulation. With regard to speed, 18 images were calculated in approximately 8 sec i.e. a single frame computation used 0.44 sec, which passes the execution gap criteria (figure 1), of less than 0.7 sec.

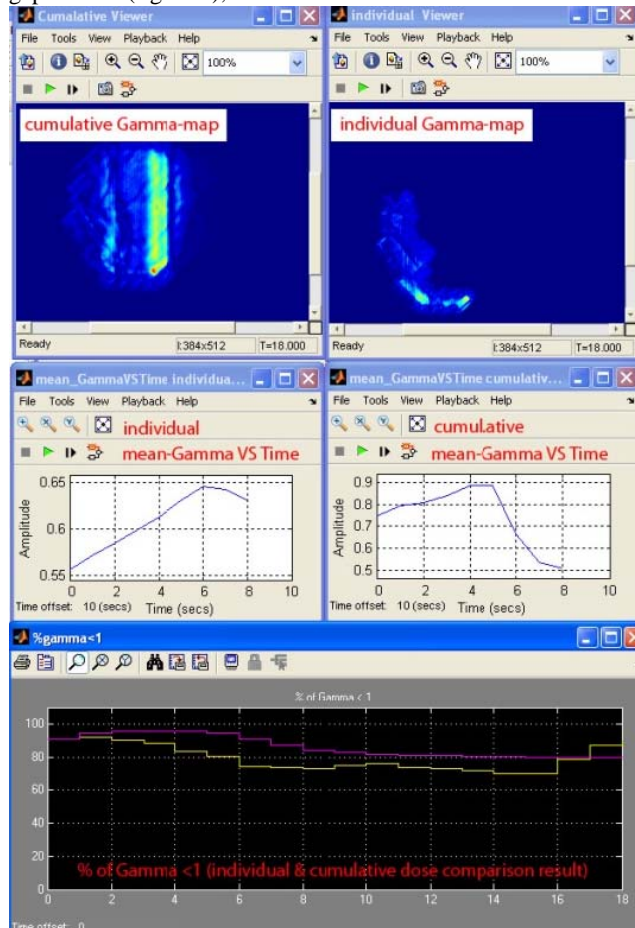

Fig. 3 Output of system, including γ Map, mean- γ , and percent of $\gamma < 1$ in both individual frame (yellow) and cumulative dose (purple) mode.

In figure 4 and figure 5, there were significant correlations between the criteria parameters and the introduced dose difference error. If the percent of dose difference error is greater than DD and DTA parameters, the system clearly detects that error. The system is also robust to noise with errors only detected if the noise level is greater than the criteria parameters.

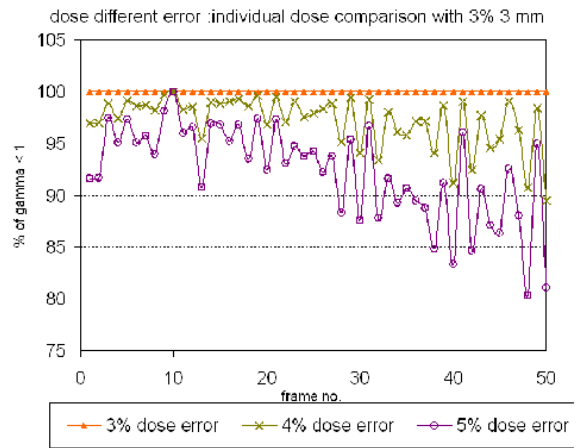

Fig. 4 result of error detection test with dose difference error

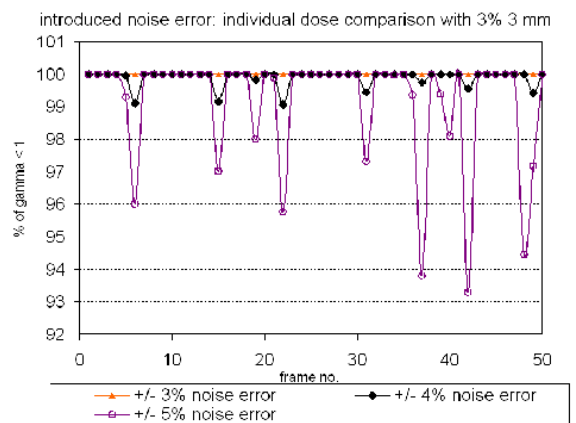

Fig. 5 Result of error detection test with noise error

For the clinical data test, a prostate cancer treatment case was used. Figure 6 shows the multileaf collimator apertures, from dose index = 0 to index = 1 in steps of 0.2, the γ -map of the individual and cumulative dose comparisons, and percent of $\gamma < 1$ relative, respectively. The frame-by-frame comparison identifies disagreement very early in the treatment but the error varies significantly, while the cumulative comparison is more stable with γ pass below 90% after 7 frames. This also shows the significant variation in the evaluated image data source with treatment day which will be a limiting factor in error detection.

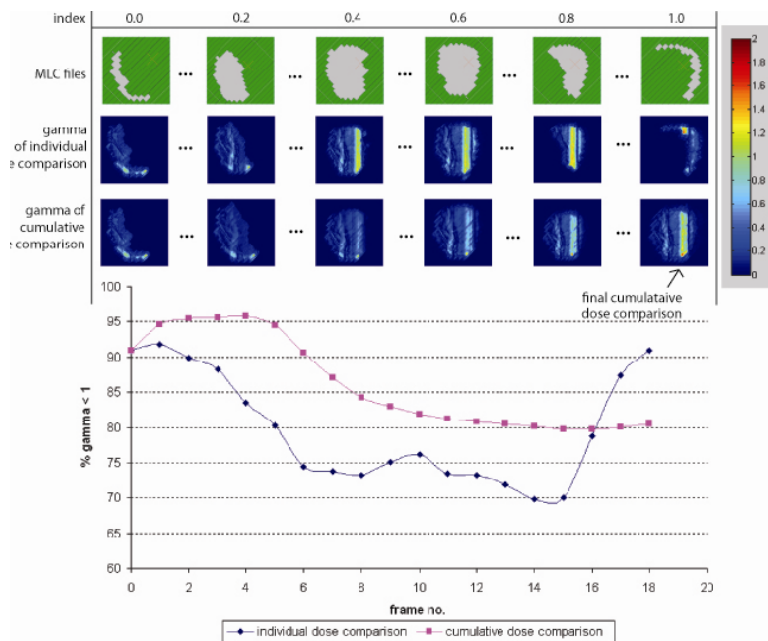

Fig. 6 The result of clinical data test with prostate case

IV. CONCLUSION

Since a well-publicized treatment delivery error resulting in a patient death [4], real-time dose verification has become a very important issue, in addition to pre and post dose verification QA procedures. The system mainly works for patient protection or detecting the delivery error by comparison of the actual dose delivery captured by EPID with the treatment plan system (real time dose prediction) or the previous treatment data.

Considering the results of our EPID-based real time dose verification with γ -evaluation tool, the individual dose comparison is more sensitive in detecting an error during the treatment delivery while the cumulative dose comparison is more stable. Moreover, the processing time of each loop must be completed before the next frame is acquired. With our general personal computer, Intel 2 Duo core 3GHz with 2GB of Ram, all calculations met the time constraints requirement, 0.7 sec execution gap. Accordingly, the EPID-based real time dose verification system can monitor the actual dose delivery compared with the treatment plan data or previous treatment dose delivery that means a radiation therapist is able to switch off the machine when the error is detected.

For the future, the development of a feasible clinical application of EPID-based real time dose verification method is essential.

REFERENCES

- [1] van Elmpt, W., L. McDermott, et al. (2008). "A literature review of electronic portal imaging for radiotherapy dosimetry." *Radiotherapy and Oncology* **88**: 289-309.
- [2] McDermott, L. N., M. Wendling, et al. (2007). "Replacing pretreatment verification with in vivo EPID dosimetry for prostate IMRT." *Int J Radiat Oncol Biol Phys* **67**(5): 1568-77.
- [3] Mans, A., M. Wendling, et al. (2010). "Catching errors with in vivo EPID dosimetry." *Med Phys* **37**(6): 2638-44.
- [4] Bogdanich, W. (2010). "Radiation Offers New Cures, and Ways to Do Harm." *From* <http://www.nytimes.com/2010/01/24/health/24radiation.html>
- [5] McCurdy, B. M. and P. B. Greer (2009). "Dosimetric properties of an amorphous-silicon EPID used in continuous acquisition mode for application to dynamic and arc IMRT." *Med Phys* **36**(7): 3028-39.
- [6] Low, D. A., W. B. Harms, et al. (1998). "A technique for the quantitative evaluation of dose distributions." *Med Phys* **25**(5): 656-61.
- [7] Stock, M., B. Kroupa, et al. (2005). "Interpretation and evaluation of the gamma index and the gamma index angle for the verification of IMRT hybrid plans." *Phys Med Biol* **50**(3): 399-411.
- [8] Jiang, S. B., G. C. Sharp, et al. (2006). "On dose distribution comparison." *Phys Med Biol* **51**(4): 759-76.