

Design of Wireless and Traceable Sensors for Internally Illuminated Photoreactors

Alexander Sutor, David Demetz

Abstract—We present methods for developing wireless and traceable sensors for photobioreactors or photoreactors in general. The main focus of application are reactors which are wirelessly powered. Due to the promising properties of the propagation of magnetic fields under water we implemented an inductive link with an on/off switched hartley-oscillator as transmitter and an LC-tank as receiver. For this inductive link we used a carrier frequency of 298 kHz. With this system we performed measurements to demonstrate the independence of the magnetic field from water or salty water. In contrast we showed the strongly reduced range of RF-transmitter-receiver systems at higher frequencies (433 MHz and 2.4 GHz) in water and in salty water. For implementing the traceability of the sensors, we performed measurements to show the well defined orientation of the magnetic field of a coil. This information will be used in future work for implementing an inductive link based traceability system for our sensors.

Keywords—Wireless sensors, traceable sensors, photoreactor, internal illumination, wireless power.

I. INTRODUCTION

WIRELESS powering for the internal illumination of photoreactors is necessary due to the limited penetration depth of photons in those media [1], [2]. Therefore, we developed internal illumination via so called Wireless Light Emitters (WLE). We designed class-E amplifiers and field coils to produce an intermediate frequency electromagnetic field inside the reactor. The magnetic flux density was selected to be approx. $B = 1\text{mT}$ in photoreactors and up to $B = 3\text{mT}$ in photocatalytic reactors in order to achieve the UV-photon power density necessary for the photocatalytic reactions [3]. The driving frequency is $f = 176\text{ kHz}$. According to our preliminary work, the intermediate frequency electromagnetic field has no negative influence on the green alga *Chlamydomonas reinhardtii* in terms of growth rate, the maximal photosynthetic yield and the maximal archived cell dry weight [1]. We conducted experiments with a laboratory size photoreactor. The cultivation volume was 30 l containing up to 3000 WLEs. The maximum electric power input was more than 300W [4]. In order to control the processes in those reactors, several sensors are necessary. In the case of photobioreactors for the cultivation of photosynthetic active microorganisms or cells, the quantities to be measured are e.g. oxygen and carbondioxide concentration, illumination, optical density and temperature. In the case of photocatalytic reactors this can also be pH-value, UV illumination and other chemical concentrations. Classically, the sensors are installed

in the reactors through a drill hole. This clearly has the drawback that the desired quantity can only be measured at one point inside the reactor and their spatial distribution is unknown. Furthermore, holes or similar ways to access the interior of the reactor have to be installed. Here, we present methods to develop wireless sensor systems to overcome these problems. The floating sensors are wirelessly powered by the magnetic field mentioned above. The sensor signals are transmitted via on-off modulation among other methods which are being tested. The modulation frequency is located a factor of 1.66 above the excitation frequency in order to avoid interference by harmonics. Additionally, standard frequencies like 433 MHz are under consideration, as used by similar projects. The battery powered sensor spheres presented in [5] send the acquired data using a 433 MHz carrier frequency. The drawback of those high frequency standard protocols is the high damping factor in electrically conducting media. The traceability of our floating sensors is another important aspect. This goal can for example be reached by evaluating the received sensor signal amplitude with an array of receiving coils.

II. PRELIMINARY WORK

Several demonstrator setups have been presented before [6], see Fig. 1.

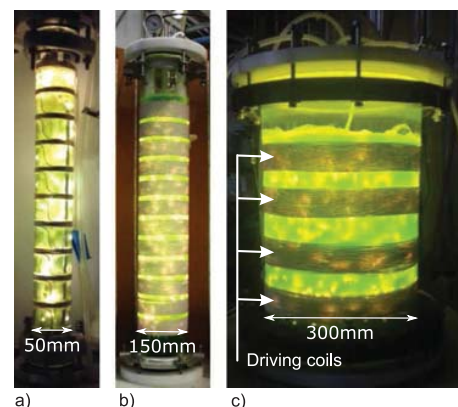

Fig. 1 Sample reactors with diameters of (a) 50 mm, (b) 150 mm, and (c) 300 mm. The largest reactor equipped with four driving coils has been used in the experiments described here

A. Sutor and D. Demetz are with the Institute of Measurement and Sensor Technology, UMIT - Private University, Hall in Tirol, Austria (email: alexander.sutor@umit.at).

The coils of the largest reactor have a total inductance of $L = 338\ \mu\text{H}$. The penetration depth δ due to the skin effect

can be calculated by

$$\delta = \frac{1}{\sqrt{\pi f \lambda \mu}}, \quad (1)$$

where λ is the electric conductivity and μ is the permeability of the medium. In this case, eddy currents in saline water have to be taken into account for larger diameters of the reactor. The medium used for cultivating the green alga *Chlamydomonas reinhardtii* has an electric conductivity of $\lambda = 0.5$ S/m. This results in a penetration depth of 1.69 m according to 1. The eddy current loss density p in W/m^3 has been calculated with the equation given by Fiorillo [7]

$$p = \frac{\pi^2}{3} \lambda B^2 f^2 r^2. \quad (2)$$

For the 30 l volume reactor (Fig. 1 (c)) this results in a loss density $p = 1690$ W/m^3 and a total loss of 50.7 W with the assumed magnetic flux density $B = 1$ mT and the radius $r = 150$ mm.

III. STATE OF THE ART

A. Data Transmission

There are a few commonly used methods for the wireless communication between underwater appliances. The three basic categories are:

- Radio Frequency (RF) / Electromagnetic (EM) data transmission
- Acoustic data transmission
- Optical data transmission

In general, the acoustic data transmission suffers from the reflections of the acoustic signals, the limited bandwidth and long transmission delays.

Optical technologies can achieve a very high bandwidth but they are susceptible to particles or turbidity [8]–[10]. Both of these technologies are not suitable for the photoreactor application. The first because of the physical separation through the reactor wall and the second one is not feasible because of the many other particles like WLEs or e.g. the algae in photobioreactors.

Much research has been made on the propagation of EM signals in water. It has been shown that the attenuation of the signal increases at higher frequencies. Due to its higher electrical conductivity, the attenuation of EM waves in sea water also increases [11]. It has been shown that at a frequency of 2.4 GHz (in fresh water) the distance with less than 30% of lost packets varies depending on the modulation mode but it is still only around 16/17 cm [12]. For lower frequencies the attenuation of the EM-waves caused by the water decreases [8].

A fourth interesting physical layer for underwater communication is the magnetic induction (MI). Because of the similar magnetic permeability, the attenuation rate of magnetic fields under water does not differ from the attenuation in the air [13]. MI-systems are widely used for data and power transmission of medical implants like pacemakers, cochlear implants or retinal implants [14]. The MI communication layer

through a resonant inductive link looks promising for the application in this aim.

Research has been done on modulation techniques to overlap a digital data signal onto a carrier signal to enable a data transmission. The modulation techniques used for the inductive links in biomedical devices are amplitude shift keying (ASK), frequency shift keying (FSK) and phase shift keying (PSK). The simplest way to implement a digital modulation is the on/off keying (OOK) [15]. An inductive link for a through-the-head communication using OOK have been implemented for the use in hearing devices [16]. The approach in [16] with an on/off switched hartley oscillator is the first approach to implement a wireless data transmission layer for the sensors in the internally illuminated photoreactor.

B. Traceability of the Sensors

For RF-signals there are some methods to locate sending items. The three basic methods are [17]:

- received-signal-strength (RSS)
- time-of-arrival (TOA)
- angle-of-arrival (AOA).

All three methods use multiple receivers at fixed positions to estimate the location of the sending item [17]. Because of the short distances TOA is not suitable for our aim. As mentioned in [18], the measurement of a sending item with a resolution of 2 cm at a frequency of 433 MHz will be difficult because the mentioned distance corresponds to only 1/35 of the wavelength. The authors of [18] underlined that AOA is not a reliable localization method. The RSS method is inexpensive, it does not need additional bandwidth and it is simple in terms of hardware implementation but their sources of error must be well known to improve the robustness of the method [17].

In the literature [19]–[22] we found some promising approaches for solving the traceability task by means of magnetic fields using multiple coil set-ups as bi- or three-axis antennas. They use the orientation of the magnetic field of a coil as basic consideration to determine the position and orientation of the sensor. In [22] the radial and tangential components of the magnetic field of a loop coil are shown. In Sec. V we measure the amplitudes at the receiver coil for different angles of the sending coil with a fixed distance between them to show the defined orientation of the magnetic field.

IV. METHODS

A. Choice of Transmission Frequency in Different Reactor Media

Because of the promising physical properties of the propagation of magnetic fields in water, the first concept to implement a communication layer between the sensors in the photoreactor and the external receivers, is an inductive link based on resonant LC-circuits. For this approach the transmission frequency is set to 298 kHz. The medium in which the measurements described in the following Section V are performed is water with different salinities. The chosen salinities are 0%, 1.75%, 3.5% and 7%. We also investigate

the range in water and in salty water of transmitter-receiver systems which are working at the standard ISM frequencies of 433 MHz and 2.4 GHz.

B. Circuits

An on/off switched hartley-oscillator has been realized as a transmitter circuit for the inductive link. Like mentioned in [16] the sending coil is the inductance of the oscillator. At receiver side a parallel LC-tank is implemented. The receiver coil of the communication system will be mounted around the outer diameter of the photoreactor. To simulate the single bits of the sensor data a pulsed signal is generated with a LM555 timer. This signal is used to switch the hartley-oscillator on and off. For this first setup the power supply for the on/off switched hartley-oscillator are two 9V batteries connected in parallel. Fig. 2 shows the circuit of this test system. The system is simulated in *NI Multisim* as well as assembled for the experimental setup.

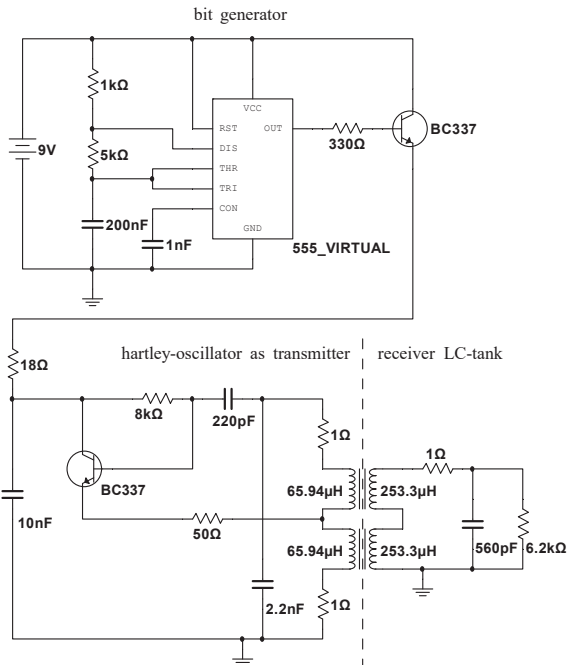

Fig. 2 Hartley-oscillator in on/off configuration as a transmitter and an LC-tank as receiver circuit

V. EXPERIMENTAL SETUP

The first experiments are made with the mentioned on/off switched hartley oscillator. The following experimental setup is used to investigate the performance of the MI communication layer under water for different salinities and distances between transmitter and receiver. A plastic container filled with 27.5 liters of water is used to carry out the measurements. The hartley-oscillator as transmitter is placed in the water and the receiver coil is mounted on the outer side of the container wall. The amplitude at receiver side is measured

for different distances between transmitter and receiver and for different salinities of the water.

Comparisons between the maximum range in air and in water with the mentioned different salinities were performed with Arduino-based transmitter-receiver systems at frequencies of 2.4 GHz and 433 MHz. These experiments are used to investigate the influence of the mentioned environment media on the performance of this systems.

As mentioned in Section III, we do perform measurements to show the defined orientation of the magnetic field of a coil. Therefore we use a setup of two coils, the sending coil produces an alternating magnetic field at a frequency of 298 kHz, the distance between the sending coil and the one of the receiver LC-tank is fixed at 20cm. The amplitude of the inducted signal at receiver side is measured for different angles α of the sending coil. Therefore the axis of the circular sending coil will be rotated like shown in Fig. 3.

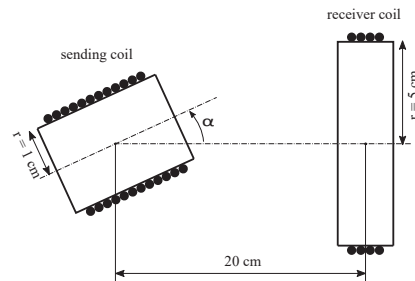

Fig. 3 Set-up for measuring the well defined orientation of the magnetic field of a coil

VI. RESULTS

The results of the measurements performed with the hartley-oscillator under water and in air are plotted in Fig. 4. The generated magnetic field of the used transmitter is also calculated for the different distances between transmitter and receiver with 3 from [23]

$$H = \frac{I_{TX} N_{TX} r_{TX}^2}{2(\sqrt{r_{TX}^2 + x^2})^3} \quad (3)$$

where $I_{TX} = 50$ mA, $N_{TX} = 90$, $r_{TX} = 1$ cm and x is the distance between transmitter and receiver.

Because of the induction law it is clear that the inducted signal strength is directly proportional to the magnetic field strength. The correlation between the calculated magnetic field and the measured amplitudes at receiver side can also be seen in Fig. 4. Equation (3) takes only the radius of the transmitting coil into account. This simplification is more noticeable at small distances between the transmitter and receiver and because of this, the correlation of the calculated magnetic field strength with the measured amplitude shows deviations at smaller distances. The different salinities do evidently not affect the inductive transmission. The small differences in the measured amplitudes are due to the manual way to perform the measurements and so due to little deviations in the transmitter-receiver distances.

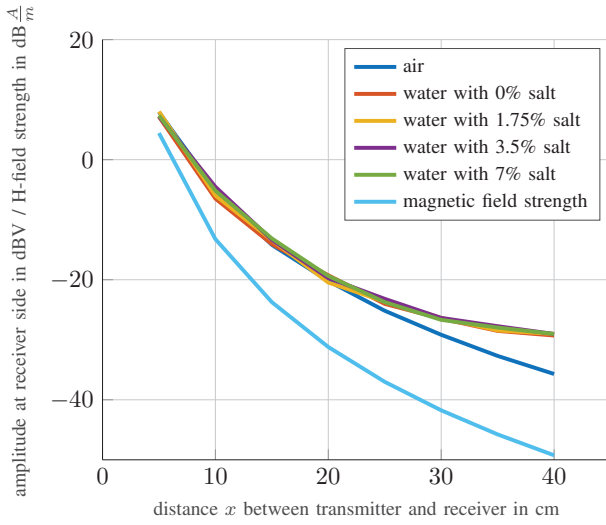

Fig. 4 Measured signal amplitude in the receiver circuit and calculated magnetic field strength for transmitter-receiver distances in the range between 5 and 40 cm

The results of the experiments with the systems at 2.4 GHz and 433 MHz are summarized in Table I. It is evident that the maximum range decreases drastically in water and even more in salty water. The results of the measurements with

TABLE I
MAXIMUM RANGES FOR THE TRANSMITTER-RECEIVER SYSTEMS AT THE FREQUENCIES 2.4 GHz AND 433 MHz

Medium	Max. range (2.4 GHz)	Max. range (433 MHz)
Air	over 30m	1m
Water	17cm	over 45cm
Water 1.75% salt	3cm	9cm
Water 3.5% salt	2cm	5cm
Water 7% salt	1cm	3cm

the setup shown in Fig. 3 are depicted in Fig. 5. It is clear that the inducted signal at secondary side has its maximum if the two coils are aligned on the same axis (0 degrees or 180 degrees). Due to the induction law, the magnetic field is directly proportional to the inducted voltage and therefore has the same distribution as the inducted voltage depicted in Fig. 5. In [22] they showed that the magnetic field of a coil excited with the current $i(t) = I \cos(\omega t)$ has a radial and tangential component. The field component which is measured with the setup shown in Fig. 3 is the radial component which can be mathematically described by the following equation [22]:

$$H_r = \frac{M}{2\pi x^3} \cos \alpha \quad (4)$$

with

$$M = NIA. \quad (5)$$

M is the magnetic moment, A the area, $N = 90$ the number of turns of the coil and $I = 50\text{mA}$ the current. The variable x is the distance between the coil and the point where the magnetic field is measured (in our case 20 cm) and α is (like in Fig. 3) the angle between the coil axis and the alignment axis. In [22] it is assumed that the coil diameter is small in comparison to the distance x , therefore they regard the coil as a point source. In Fig. 5 we also plotted the absolute value of 4.

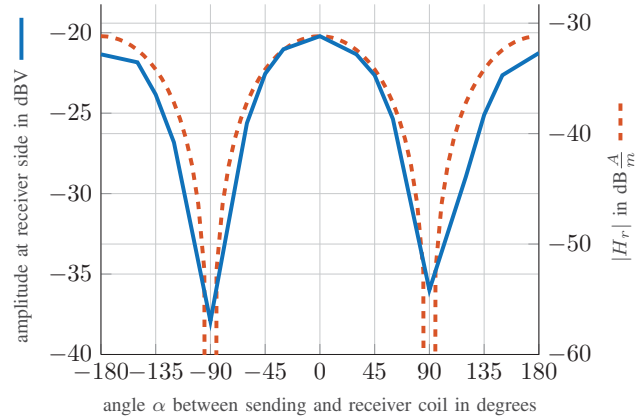

Fig. 5 Measured signal amplitude in the receiver circuit for different angles of the sending coil for a fixed distance of 20 cm between them

VII. CONCLUSION AND OUTLOOK

For wireless sensors in internally illuminated photoreactors the use of an inductive link as a communication layer between sensors (as transmitters) in the reactor and receivers outside the reactor, showed promising results due to the independence of the magnetic field from water or salty water. We implemented an on-off switched hartley oscillator as a transmitter to simulate the single bits of the sensor data. The modulation frequency has been set to 298 kHz and no differences in performance could be detected using water in different salinities as a propagation medium. Using RF-signals at higher frequencies the range decreases clearly when the medium changes from air to water and even more in salty water. The 2.4 GHz system did not prove to be suitable for our aim. The range decreased from over 30 meters in air to a few cm in water. The 433 MHz system requires more investigations. It showed a loss of performance in water and even more in salty water but the system used for the experiments had a very limited range also in air (only ca. 1m). A negative influence of water (and salty water) could be shown but at the moment it is not clear if this negative aspects can be overcome with a better/more convenient system architecture. The traceability of the sensors was not implemented yet it will be a future task of this project. In the literature we already found promising approaches for measuring the position and orientation of sensors through inductive links [19]–[22]. By the measurements we performed, we showed the defined orientation of the magnetic field of a coil. This property

will be used in future work to implement the traceability of the sensors. It can be concluded that for both aspects signal transmission and traceability, the MI-method seems to be superior to both RF-methods.

REFERENCES

- [1] M. Heining, A. Sutor, S. Stute, C. Lindenberger, and R. Buchholz, "Internal illumination of photobioreactors via wireless light emitters: a proof of concept," *Journal of Applied Phycology*, vol. 27, pp. 59–66, 2015.
- [2] A. M. Murray, I. A. Fotidis, A. Isenschmid, K. R. A. Haxthausen, and I. Angelidaki, "Wirelessly powered submerged-light illuminated photobioreactors for efficient microalgae cultivation," *Algal Research*, vol. 25, pp. 244 – 251, 2017. (online). Available: <http://www.sciencedirect.com/science/article/pii/S2211926416306397>
- [3] B. O. Burek, A. Sutor, D. W. Bahnemann, and J. Z. Bloh, "Completely integrated wirelessly-powered photocatalyst-coated spheres as a novel means to perform heterogeneous photocatalytic reactions," *Catal. Sci. Technol.*, vol. 7, no. 21, pp. 4977–4983, 2017.
- [4] A. Sutor, M. Heining, and R. Buchholz, "A class-e amplifier for a loosely coupled inductive power transfer system with multiple receivers," *Energies*, vol. 12, no. 6, 2019. (online). Available: <https://www.mdpi.com/1996-1073/12/6/1165>
- [5] T. Lauterbach, F. Lenk, T. Walther, T. Germandt, R. Moll, F. Seidel, D. Brunner, T. Lke, C. Hedayat, M. Bker, and A. Peters, "Sens-o-spheres mobile, miniaturisierte sensorplattform fr die ortsungebundene prozessmessung in reaktionsgefen," *13. Dresdner Sensor-Symposium 2017, Hotel Elbflorenz, Dresden*, pp. 89 – 93, 12 2017.
- [6] M. Heining and R. Buchholz, "Photobioreactors with internal illumination - a survey and comparison," *Biotechnology Journal*, vol. 10, no. 8, pp. 1131–1137, 2015.
- [7] F. Fiorillo, *Characterization and measurement of magnetic materials*. Academic Press, 2004, pp.25-36.
- [8] X. Che, I. Wells, G. Dickers, P. Kear, and X. Gong, "Re-evaluation of rf electromagnetic communication in underwater sensor networks," *IEEE Communications Magazine*, vol. 48, no. 12, pp. 143–151, December 2010.
- [9] Y. Li, H. Yin, X. Ji, and B. Wu, "Design and implementation of underwater wireless optical communication system with high-speed and full-duplex using blue/green light," in *2018 10th International Conference on Communication Software and Networks (ICCSN)*, July 2018, pp. 99–103.
- [10] J. Shi, S. Zhang, and C. Yang, "High frequency rf based non-contact underwater communication," in *2012 Oceans - Yeosu*, May 2012, pp. 1–6.
- [11] U. M. Qureshi, F. K. Shaikh, Z. Aziz, S. M. Z. S. Shah, A. A. Sheikh, E. Felemban, and S. B. Qaisar, "Rf path and absorption loss estimation for underwater wireless sensor networks in different water environments," *Sensors*, vol. 16, no. 6, 2016. (online). Available: <https://www.mdpi.com/1424-8220/16/6/890>
- [12] J. Lloret, S. Sendra, M. Ardid, and J. J. P. C. Rodrigues, "Underwater wireless sensor communications in the 2.4 ghz ism frequency band," *Sensors*, vol. 12, no. 4, pp. 4237–4264, 2012. (online). Available: <https://www.mdpi.com/1424-8220/12/4/4237>
- [13] M. C. Domingo, "Magnetic induction for underwater wireless communication networks," *IEEE Transactions on Antennas and Propagation*, vol. 60, no. 6, pp. 2929–2939, June 2012.
- [14] H. Ali, T. J. Ahmad, and S. A. Khan, "Inductive link design for medical implants," in *2009 IEEE Symposium on Industrial Electronics Applications*, vol. 2, Oct 2009, pp. 694–699.
- [15] M. A. Hannan, S. M. Abbas, S. A. Samad, and A. Hussain, "Modulation techniques for biomedical implanted devices and their challenges," *Sensors*, vol. 12, no. 1, pp. 297–319, 2012. (online). Available: <https://www.mdpi.com/1424-8220/12/1/297>
- [16] J. Edelmann, R. Stojakovic, C. Bauer, and T. Ussmueller, "An inductive through-the-head ook communication platform for assistive listening devices," in *2018 IEEE Topical Conference on Wireless Sensors and Sensor Networks (WiSNet)*, Jan 2018, pp. 30–33.
- [17] N. Patwari, J. N. Ash, S. Kyperountas, A. O. Hero, R. L. Moses, and N. S. Correal, "Locating the nodes: cooperative localization in wireless sensor networks," *IEEE Signal Processing Magazine*, vol. 22, no. 4, pp. 54–69, July 2005.
- [18] T. Shah, S. M. Aziz, and T. Vaithianathan, "Development of a tracking algorithm for an in-vivo rf capsule prototype," in *2006 International Conference on Electrical and Computer Engineering*, Dec 2006, pp. 173–176.
- [19] P. K. Hansen, "Method and apparatus for position and orientation measurement using a magnetic field and retransmission," Patent, May, 1984, US4642786A. (online). Available: <https://patents.google.com/patent/US4642786A>
- [20] E. Paperno, I. Sasada, and E. Leonovich, "A new method for magnetic position and orientation tracking," *IEEE Transactions on Magnetics*, vol. 37, no. 4, pp. 1938–1940, July 2001.
- [21] E. Paperno and P. Keisar, "Three-dimensional magnetic tracking of biaxial sensors," *IEEE Transactions on Magnetics*, vol. 40, no. 3, pp. 1530–1536, May 2004.
- [22] F. H. Raab, E. B. Blood, T. O. Steiner, and H. R. Jones, "Magnetic position and orientation tracking system," *IEEE Transactions on Aerospace and Electronic Systems*, vol. AES-15, no. 5, pp. 709–718, Sep. 1979.
- [23] J. Agbinya, *Principles of Inductive Near Field Communications for Internet of Things*, ser. River Publishers series on communications. River Publishers, 2011. (online). Available: <https://books.google.at/books?id=3D07yNMSNp0C>