

Design of the Miniature Maglev using Hybrid Magnets in Magnetic Levitation System

Jeong-Min Jo, Young-Jae Han, Chang-Young Lee

Abstract—Attracting ferromagnetic forces between magnet and reaction rail provide the supporting force in Electromagnetic Suspension. Miniature maglev using permanent magnets and electromagnets is based on the idea to generate the nominal magnetic force by permanent magnets and superimpose the variable magnetic field required for stabilization by currents flowing through control windings in electromagnets. Permanent magnets with a high energy density have lower power losses with regard to supporting force and magnet weight. So the advantage of the maglev using electromagnets and permanent magnets is partially reduced by the power required to feed the remaining onboard supply system so that the overall onboard power is diminished as compared to that of the electromagnet. In this paper we proposed the how to design and control the miniature maglev and confirmed the feasibility of the levitation system using electromagnets and permanent magnets through the manufacturing the miniature maglev

Keywords—Magnetic Levitation system, Maglev, Permanent Magnets, Hybrid Magnet

I. INTRODUCTION

MAGNETICALLY levitated trains provide a high speed, very low friction alternative to conventional trains with steel wheels on steel rails. Several experimental maglev systems in Germany and Japan have demonstrated that this mode of transportation can profitably compete with air travel. More importantly, maglev transportation can ease traffic congestion and save energy. Maglev transportation uses magnetic levitation and electromagnetic propulsion to provide contactless vehicle movement. There are two basic types of magnetic levitation: electromagnetic suspension (EMS) and electro-dynamic suspension (EDS). In EMS, the guideway attracts the electromagnets of the vehicle that wraps around the guideway. The attracting force suspends the vehicle about one centimeter above the guideway. In contrast, the EDS systems use repulsive force, induced by the magnets on the vehicle, to lift the vehicle [1]-[2]. In this paper EMS using electromagnet and permanent magnet is studied. EMS using Hybrid magnets can reduce the weight of the levitation system and power electronic system compared to conventional EMS.

J.M. Jo is with the Korea Railroad Research Institute, Uiwang-Si, Gyeonggi-Do, South Korea, 437-7657 (phone : +82-31-460-5619; fax: +82-31-460-5023; e-mail: jmjo@krii.re.kr).

Y.J. Han is with the Korea Railroad Research Institute, Uiwang-Si, Gyeonggi-Do, South Korea, 437-7657 (phone : +82-31-460-5614; fax: +82-31-460-5023; e-mail: yjhan@krii.re.kr)

C.Y. Lee is with the Korea Railroad Research Institute, Uiwang-Si, Gyeonggi-Do, South Korea, 437-7657 (phone : +82-31-460-5525; fax: +82-31-460-5023; e-mail: cylee@krii.re.kr)

The hybrid magnet based on permanent magnets and electromagnets has advantages such as the reduced power to feed the remaining onboard supply system, so the overall onboard power is diminished by about 20% as compared to that of the electromagnet [3].

In this paper we proposed the how to design and control the miniature maglev and confirmed the feasibility of the levitation system using electromagnets and permanent magnets through the manufacturing the miniature maglev.

II. MINIATURE MAGLEV SYSTEM

A. Concept of the Miniature Maglev System

The miniature maglev is magnetically levitated and propelled by linear induction motor along a guideway. The vehicle is supported by four magnets on levitation frame below the guideway beam. The miniature maglev using permanent magnets and electromagnets is based on the idea to generate the nominal magnetic force by permanent magnets and superimpose the variable magnetic field required for stabilization by currents flowing through control windings in electromagnets.

A miniature maglev consists of a LIM (Linear Induction Motor), four hybrid magnets and a magnet drive and a communication system. The system parameters are summarized in Table I.

TABLE I
PARAMETERS OF A MINIATURE MAGLEV

Parameter	Value	Remark
System Weight	40kg	Max. 48kg
Levitation Magnet type	Hybrid Magnets (Permanent Magnets + Electromagnets)	NdFeB
Operating air gap	5mm	
Max Vehicle Speed	0.5[m/sec]	
Communication Device	Bluetooth	

B. Magnet Drive

A magnet driver consists of 4 quadrant chopper and levitation controller. Fig. 1 shows the block diagram of the hybrid levitation control system. The total magnet force acting at each module is due to a permanent magnet and a normal control coil. The permanent magnet provides the magnet force to support the miniature maglev in static equilibrium. The control coil generates the perturbation force.

The magnetic coil current is controlled as a function of the magnetic air gap. For this purpose, an air gap and acceleration signals from hybrid levitation magnet are measured and

transmitted to a controller whose output signal is sent to a hybrid magnet chopper. In controller the input signals are transformed to filtered gap and filtered acceleration and gap velocity. These values are multiplied by a gain matrix and added in order to make reference output voltage of controller. The reference output voltage is transformed to PWM. The four magnets in the vehicle are controlled independently through four controllers.

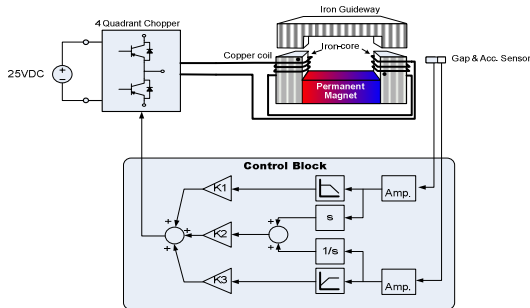

Fig. 1 Block Diagram of the Levitation Control System

C. Hybrid magnets

The magnet force acting at each corner module is due to a permanent magnet and a levitation control coil. The permanent magnet primarily provides the magnet force to levitate the miniature maglev in operating point. Air-gap variations are accommodated by continually changing the current in the control coils. Therefore the magnetic coil current is controlled as a function of the magnetic air gap.

Fig. 2 shows magnetic flux distribution calculated with the 3-D code in the air-gap of 3mm, pole and rail iron. The attractive force of permanent magnet computed by the 3-D model is 20% smaller than that of experimental results. Fig. 2 shows the flux density of the iron core for air-gap of 3mm is about 0.4 Tesla.

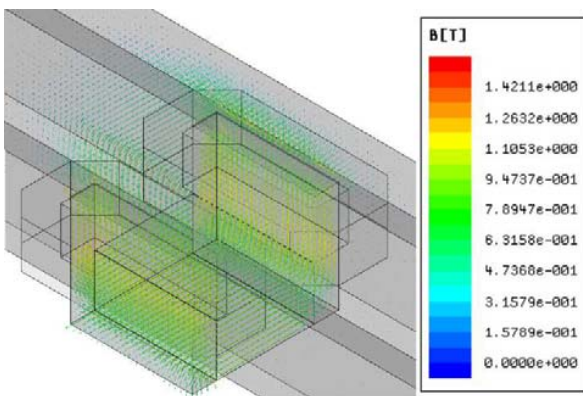

Fig. 2 3-D Flux density Vector for air-gap of 3mm and magnet coil current of 0A

Fig. 3 shows the 3-D flux density vector generated by a permanent magnet and two electromagnets for coil current of 5A and the maximum flux density of the iron core is 1.2Tesla.

If the magnet is to be driven on the linear part of its B-H characteristics, allowing for a 50% flux overload margin, typical nominal air-gap flux may be assumed to be around 0.5 Tesla.

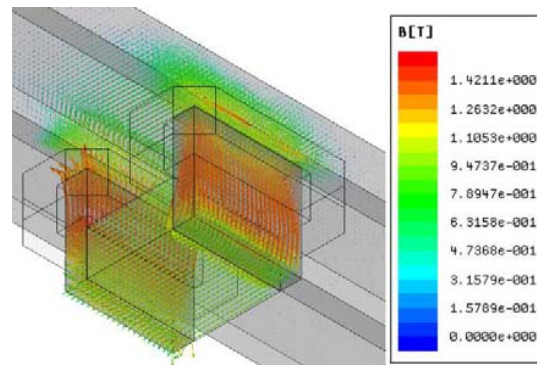

Fig. 3 3-D Flux density Vector for air-gap of 5.5mm and magnet coil current of 5A

Fig. 4 shows the attraction force for a magnet coil current at different air-gaps. The weight of the miniature maglev is about 40kg and attraction force at air-gap of 4mm is 40kgf. Therefore, this equilibrium position of air-gap to the weight of the miniature maglev is about 4mm.

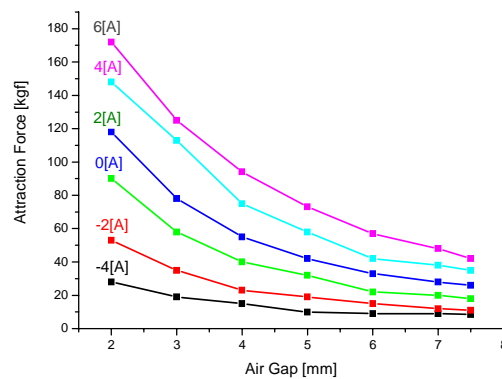

Fig. 4 Attraction force for a magnet coil current at air-gaps from 2mm to 7.5mm

D. Linear Induction Motor

Since suspension is achieved without any physical contact, linear motors are chosen to propel these magnetically levitated vehicles. In this design linear induction motor is chosen because linear induction motor has the advantage in lower price and simpler construction. Fig. 5 shows the flux density of LIM at the slip frequency of 0.95. The two dimensional mesh geometry of SLIM has been solved for analysis of magnetic flux density.



Fig. 5 Flux density of LIM at the slip frequency of 0.95

Fig. 6 shows the influence of normal force for vehicle speed at different current frequencies of LIM and Fig. 7 shows the thrust force of LIM at the current frequencies from 35Hz to 65Hz.

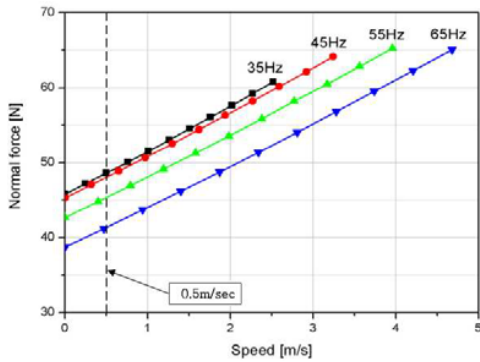

Fig. 6 Normal force for vehicle speed at the different current frequencies of LIM

These results indicate that the variations of normal force for vehicle speed at the different current frequencies of LIM affect to the magnet control system. So variations in normal force are compensated by the constant slip frequency control in an inverter for LIM.

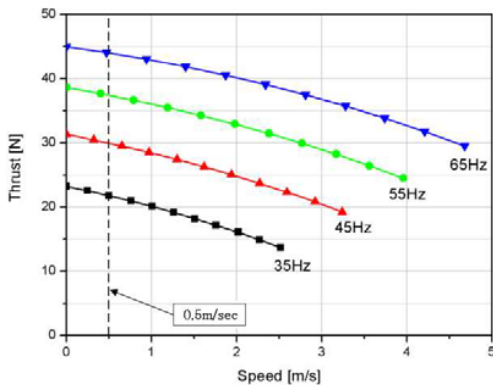

Fig. 7 Thrust force for vehicle speed at the different frequencies

E. Control of LIM drive

This miniature maglev system consists of LIM driven electromagnetically suspended vehicle system. The design for the control of LIM drive was implemented using a closed-loop system with PWM. Fig. 8 shows a block diagram for propulsion system.

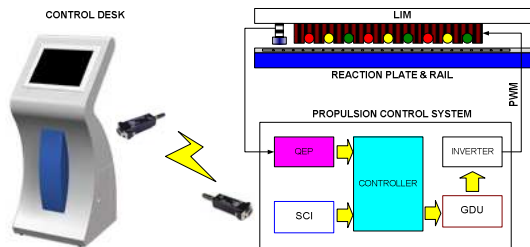

Fig. 8 Block Diagram for propulsion system

Photo sensors under the bogie of vehicle read a scale on the rail and then the signals from photo sensors are sent to the propulsion control system. The QEP circuit counts the quadrature encoded input pulse on the QEP input pin in order to estimate the vehicle speed.

A vehicle speed reference value is set from the control desk. A speed controller calculates the reference current and then reference current values are transformed to PWM.

III. EXPERIMENTAL VERIFICATION

A miniature maglev was used to confirm the feasibility of levitation system using hybrid magnets. In the test the vehicle negotiates a guideway at 0.5m/sec for 5m. The steady-space control is applied for electromagnetic levitation controller of each magnet module. Fig. 9 shows the miniature maglev with hybrid levitation system using permanent magnet and electromagnets.



Fig. 9 The miniature maglev using hybrid magnets

Fig. 10 shows an air-gap and magnet coil current while the position of the miniature maglev moves up and down softly to the rail. Magnet coil current increase until magnet is off from the rail and decrease until air-gap reach to the operating point.

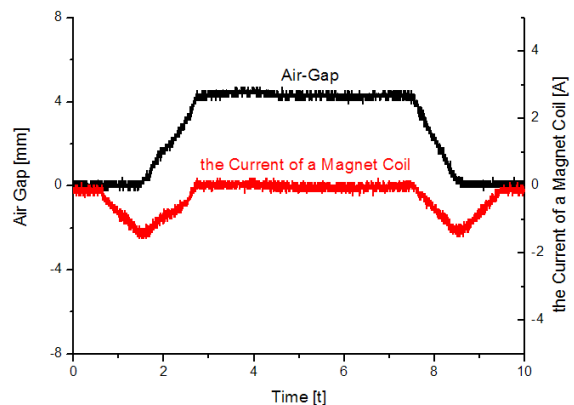

Fig. 10 An air-gap and current waveforms for the soft up-and-down motion of the position

From the results, we can see that the equilibrium position of air-gap to the weight of the miniature maglev is about 4.5mm and the energy consumption at the operating position is near to zero.

Fig. 11 and Fig. 12 show an air-gap and magnet coil current for the soft up-and-down motion of the position and the step-up motion of the position respectively. These figures show that the response time to the step reference is about 100msec. from these results, the feasibility of EMS using hybrid magnet is confirmed.

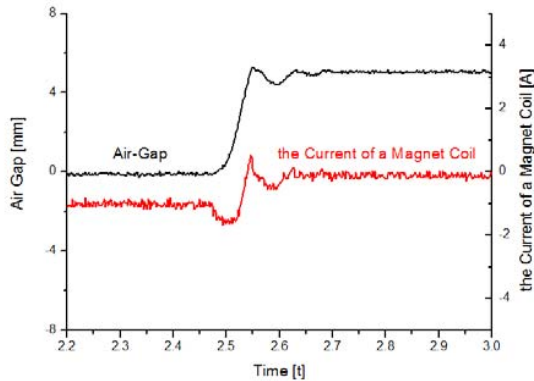

Fig. 11 An air-gap and magnet coil current for the step-up motion of the position

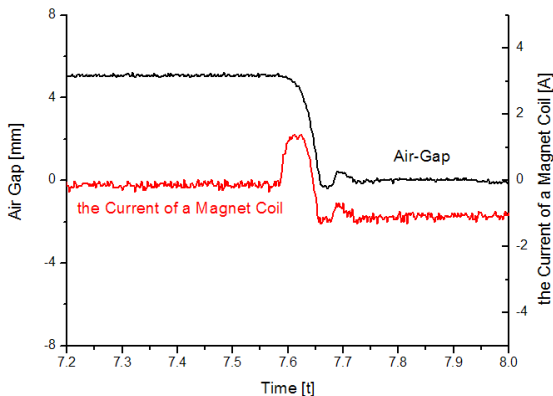

Fig. 12 An air-gap and magnet coil current for the step-down motion of the position

Fig. 13 shows air-gap and magnet coil current when vehicle runs on the rail. The figure shows gap fluctuation is about 0.5mm (pk-pk). The major cause of the gap fluctuation is rail joints on the guideway.

From experimental results the levitation system using hybrid magnet and 4-quadrant chopper have advantages such as a low consumption and lower required DC link voltage in magnet drives.

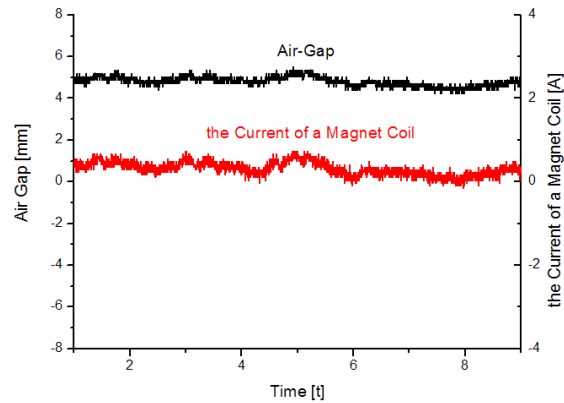

Fig. 13 Air-gap and magnet coil current at running on the guideway

IV. CONCLUSION

This paper presents the miniature maglev using permanent magnets and electromagnets which is based on the idea to generate the nominal magnetic force by permanent magnets and superimpose the variable magnetic field required for stabilization by currents flowing through control windings in electromagnets. Based on the miniature maglev, how to design and control the miniature maglev are discussed. In order to confirm the feasibility of the levitation system using electromagnets and permanent magnets, experimental work is performed. Experimental results show that the hybrid magnet based on permanent magnets and electromagnets has advantages such as the reduced power to feed the remaining onboard supply system, so the overall onboard power is diminished by about over 50% as compared to that of the electromagnet.

ACKNOWLEDGMENT

This work was supported by Royalty Project through Korea Institute of Construction & Transportation Technology Evaluation and Planning (KICTEP) funded by Korean Ministry of Land, Transport and Maritime Affairs (10ENGF-C055954-01-000000)

REFERENCES

- [1] Feng Zhao and Richard Thornton, "Automatic Design of a Maglev Controller in State Space," Proceedings of the 31st Conference on Decision and Control, Tucson, Arizona, December 1992
- [2] G. Bohn. And G. Steinmetz, "The electromagnetic Levitation and Guidance Technology of The 'TRANSRAPID' Test Facility," IEEE TRANSACTIONS ON MAGNETICS, Vol. MAG-20, NO. 5, SEPTEMBER, pp. 1666-1671, 1984
- [3] W.J. Mayer and J. Meins, "The use of Electromagnets and Permanent Magnets in Magnetic Levitation Technology," JOURNAL DE PHYSIQUE, 1984, pp C1-739- C1745