

Design of Synchronous Torque Couplers

M. H. Nagrial, J. Rizk, A. Hellany

Abstract—This paper presents the design, analysis and development of permanent magnet (PM) torque couplers. These couplers employ rare-earth magnets. Based on finite element analysis and earlier analytical works both concentric and face-type synchronous type couplers have been designed and fabricated. The experimental performance has good correlation with finite element calculations.

Keywords—Finite Element Analysis, Synchronous Torque Couplers, Permanent Magnet Torque Couplers

I. INTRODUCTION

RECENT developments in rare-earth permanent magnet materials such as Samarium Cobalt (SmCo_5) and Neodymium Iron Boron (Nd-Fe-B) have created new interests in their applications in electromechanical devices. These new materials can be efficiently used in devices with large air gaps such as slotless electrical machines and torque couplers. Permanent magnet couplers are employed for non-contact transmission of forces and torques [1-8]. Permanent magnet couplers have added advantage of torque limitation in critical applications to avoid mechanical failure due to torque overloads. Rapid increase in magnet strength has allowed for a corresponding reduction in the size and weight of such couplers. The containment shell or separation wall may or may not be metallic. In a metallic shell, extra care is required to reduce heat due to eddy currents while a non-metallic shell generates no eddy currents.

These couplers are finding wide use in seal-less pumps, process and chemical industries and other such applications where the driving and driven parts are separated by mechanical wall. Due to the use of rare-earth magnets, the present generation of couplers results in the following advantages.

- Minimum space and size
- Larger air gaps possible
- No risk of demagnetisation
- Simple and reduced size bearings
- Lower moments of inertia
- Higher torque/volume resulting in reduced overall cost.

The magnetic torque couplers are essentially of the

following three types:

- Synchronous
- Permanent magnet
- Variable reluctance
- Eddy current
- Hysteresis

In synchronous type couplers, both coupling halves are fitted with permanent magnets in a multipole arrangement and both halves move at the same speed. The transmitted torque is dependent only on the relative angle of displacement of the coupling halves. It is essential that the magnetisation of both coupling halves must be constant in time and space, i.e. no demagnetisation when slip occurs. It has been possible with the availability of rare-earth permanent magnets with high coercivity. The synchronous couplers have no slippage between the two halves, unlike hysteresis and eddy current couplers

Another version of synchronous torque couplers is variable reluctance (V. R) coupler when one member is fitted with permanent magnets while other member is magnetic steel with salient poles [9]. Such a coupler has different torque angle characteristics compared with permanent magnet torque coupler, where both members are fitted with permanent magnets.

This paper presents the analysis, design and performance of synchronous type couplers. The synchronous type couplers can further be divided into two main types:

- Coaxial or concentric
- Face or butt-ended or axial.

The present investigation is devoted to both types of torque couplers. Coaxial couplers have one member rotate inside a tube while face or butt-ended couplers operate end on through a plane partition. In the latter type, with their opposing surfaces under multipolar magnetisation, considerable axial forces can occur which have to be absorbed by the bearings. These couplers are generally used for smaller torque while coaxial couplers are used for transmitting larger torque. The transmitted torque is independent of speed and dependent only on the relative angle of displacement of the coupler halves. The axial or face type couplers have added advantage of easy adjustment of air gap.

The present investigation provided a useful basis to optimise the design of magnetic torque couplers of various sizes and configurations. Finite element method has been employed to predict the performance, which is verified by experimental work. An experimental set up is developed to measure the torque as a function of displacement. The experimental and

Professor M. Nagrial is with the University of Western Sydney, Locked Bag 1797 Penrith South DC 1797, NSW Australia(phone: +61 247360827; fax: +61 247360833; e-mail: m.nagrial@uws.edu.au).

Dr Jamal Rizk is with the University of Western Sydney, Locked Bag 1797 Penrith South Dc 1797, NSW Australia (e-mail: j.rizk@uws.edu.au).

Dr. Ali Hellany is with the University of Western Sydney, Locked Bag 1797 Penrith South DC 1797 NSW Australia (e-mail: a.hellany@uws.edu.au).

finite element results have confirmed earlier analytical optimisation studies.

In synchronous motors, it is desirable to have overload capability, but in synchronous torque couplers it can be a disadvantage to have excessive overload capability. The magnetic couplers are expected to operate near to pull-out point and must pull-out of synchronism if the overload exceeds a certain amount to avoid damage to driven parts

Figure 1(a) shows the configuration of concentric type while Figure 1(b) shows face or axial type synchronous coupler. As shown, the couplers are generally designed with multi-poles, although there is an upper optimum limit on the number of poles depending on the size and other design dimensions [10-11].

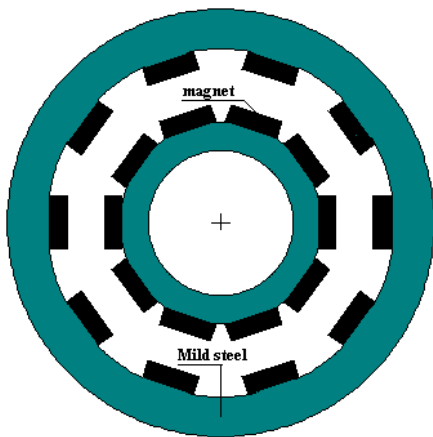

Fig. 1(a) Concentric torque coupler

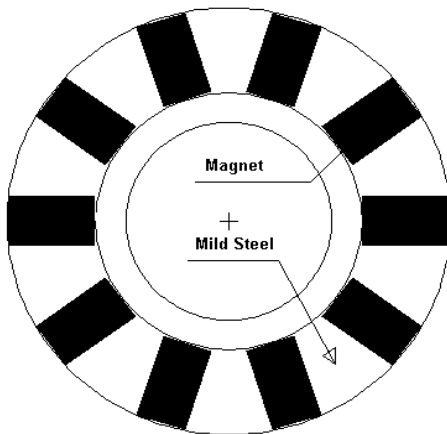

Fig. 1(b) Face-type torque coupler

II. ANALYSIS AND DESIGN

Several factors are taken into account in the design of synchronous torque couplers. Various criteria can be used to optimise the design of such devices [12].

- Maximum torque/magnet volume
- Maximum torque/coupling volume
- Minimum cost of materials or production.

There are various design dimensions which influence the maximum torque of synchronous torque couplers such as air gap length, diameter, size of magnets, number of pole pairs, pole pitch and pole arc, etc. A comprehensive study on the effect of such design parameters and performance has been reported [13]. Though other types of permanent magnet materials are available, rare-earth magnets (Nd-Fe-B) are employed in the present investigation due to their high strength. Finite element method is employed to calculate torque produced by torque couplers. Finite element method can be used to calculate the torque from the magnetic field, by using either of the following two methods [14-15].

Principle of virtual work

The force or torque exerted on a pole may be evaluated by determining the work done when it is slightly displaced from its initial position. The energy stored in an air gap is given by

$$W_{f1} = \frac{(B_{g1})^2 (V_{ag})}{2\mu_0} \quad (1)$$

Where B_{g1} = air gap flux density

μ_0 = permeability of free space

V_{ag} = air gap volume

If a pole is displaced relative to its opposite pole by a distance dx , the total flux is assumed not to change but to become concentrated in the air gaps. The new flux density can be given by:

$$B_{g2} = \frac{(B_{g1})}{(x - dx)} x \quad (2)$$

The energy in the air gap increases to:

$$W_{f2} = \frac{(B_{g1})^2 (V_{ag})}{2\mu_0 (x - dx)} = \frac{(B_{g2})^2 (V_{ag})}{2\mu_0} \quad (3)$$

This increase in energy is equal to the work done in displacing the pole by a distance dx and can be written as follows:

$$dW = \frac{(B_{g1})^2 (V_{ag})}{2\mu_0 (x - dx)} dx \quad (4)$$

The tractive force can be calculated as follows:

$$F = \frac{dW}{dx} = \frac{(B_g l)^2 (V ag)}{2\mu_0 (x - dx)} \quad (5)$$

The above can be translated into torque equation, if the axial displacement can be replaced with angular displacement, i.e.

$$T = \frac{dW}{d\theta} = \frac{\delta W}{\delta\theta} \quad (6)$$

From the principle of conservation of energy, the incremental energy balance equation may be written as

$$dW_{mech} + dW_s = dW_f$$

or

$$Td\theta + \int_v \bar{H} d\bar{B} dv = d \int_0^{\bar{B}} \bar{H}(\bar{B}) d\bar{B} dv \quad (7)$$

Where

T	=	torque
θ	=	rotational angle
$d\theta$	=	small displacement
H	=	magnetic field intensity
B	=	flux density

The above equation is employed in finite element methods and can be simplified to obtain the torque as follows:

$$\bar{T} = \frac{d \int_v \bar{H} d\bar{B} dv}{d\theta} \quad (8)$$

Maxwell Stress Method

Unlike the virtual work method, the Maxwell stress approach computes local stress at all points of a bounding surface and then sums the local stresses by means of a surface integral. It can be explained as follows: The calculation of tractive forces per unit area between two pole faces can be calculated by:

$$F/A = \frac{J_a J_b}{2\mu_0} \quad (9)$$

Where J_a and J_b are the respective magnetisations of two magnets under consideration and the permeability of free space. At short air gaps, J_a can be assumed to be equal to J_b and air gap density B_g . Hence Equation (9) can be written as:

$$\frac{F}{A} = \frac{B_g^2}{2\mu_0} = \frac{H_g^2 \mu_0}{2} \quad (10)$$

It can be expressed in ϕ integral form as follows:

$$F = \int_s \mu_0 \bar{H}(\bar{n} \cdot \bar{H}) - \frac{\mu_0}{2} (\bar{H} \cdot \bar{H}) \bar{n} \quad (11)$$

Where \bar{n} is the unit outward normal to the surface s which is any closed surface surrounding the body. The component of the force tangential to the surface is:

$$F = \int \mu_0 H_t H_n dS \quad (12)$$

Where H_t and H_n are the tangential and normal components of the field, respectively. The above two methods are used to compute the torque in synchronous type couplers using the finite element package. The computed results using the above two methods are compared with experimental results.

III. EXPERIMENTAL RESULTS

Based on initial studies and earlier work, two synchronous type couplers are analysed and fabricated using Nd-Fe-B magnets [10-11]. One coupler is a coaxial type while the other is of axial or face type. Finite element method is used to predict the flux distribution, torque and other performance parameters. The experimental couplers are shown in the Appendix. Figure 2 shows the radial magnetic flux distribution in the coaxial coupler in aligned and in unaligned positions. Figure 3 shows the axial flux distribution in axial coupler. The coaxial coupler is a 10-polar design while axial coupler is a 12-polar design.

Figure 4 shows the torque of a synchronous coupler as a function of displacement. The torque in such couplers is a function of angular displacement and varies as a sinusoid

The displacement angle is shown as dimensionless parameter, normalised as a function of pole pitch. The pole arcs and number of poles are selected as to result in an optimum pole arc/pole pitch ratio [7-10]. Table 1 shows the pull-out torques, calculated and experimental, in both types of couplers. Table 1, also, shows the computed results using both methods as explained earlier. The axial coupler has the advantage of easy adjustment of air gap but it has the disadvantage of axial forces on the bearings. Figure 5 shows the variation of pull-out torque as a function of air gap length for axial coupler. It is rather easy to vary the air gap length in such couplers compared with coaxial couplers where the air gap is almost fixed. By adjusting the air gap, an axial coupler can be easily modified for various applications.

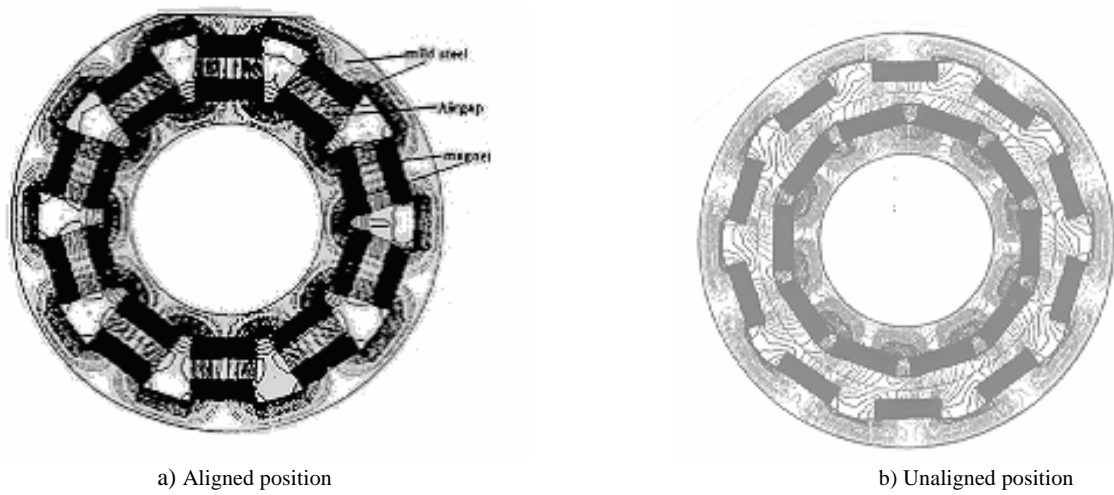

Fig. 2 Magnetic flux distribution (concentric coupler)

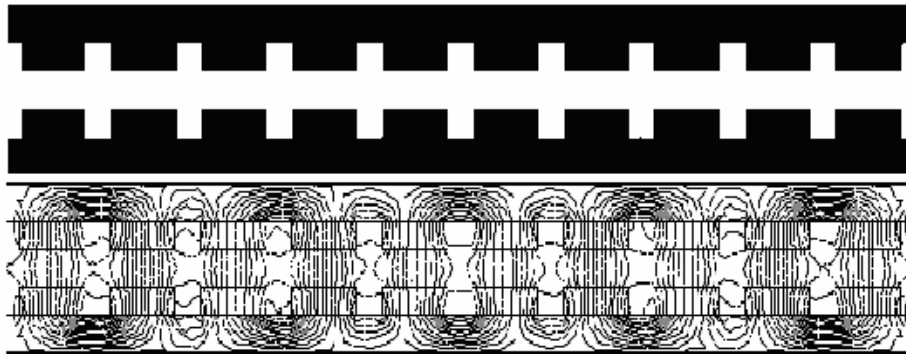

Fig. 3 Magnetic flux distribution (axial coupler)

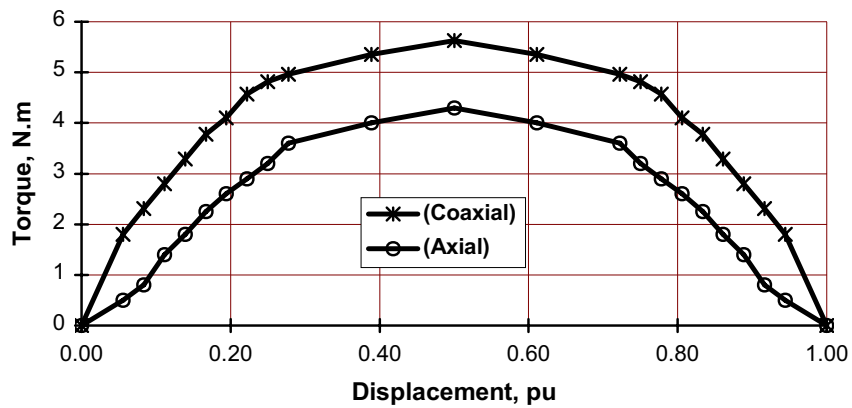

Fig. 4 Torque vs displacement for synchronous torque couplers

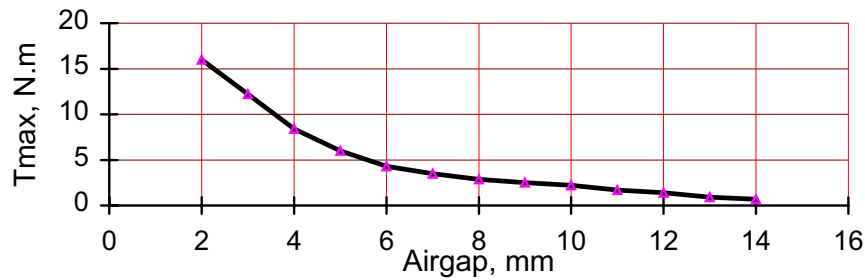

Fig. 5 Pull-out torque vs air gap length (axial coupler)

TABLE I
CALCULATED AND EXPERIMENTAL PULL-OUT TORQUES

	Virtual work (Nm)	Maxwell Stress (Nm)	Experimental (Nm)
Coaxial Coupler	5.65	5.55	5.629
Axial Coupler	4.45	4.12	4.36

A wheel and pulley arrangement has been fabricated to measure the experimental torque as a function of displacement. The present investigation has provided a useful basis to optimise the design of magnetic torque couplers of various sizes and configurations. The experimental and finite element results have confirmed earlier analytical optimisation studies.

IV. CONCLUSIONS

The design of DC brushless motors with slotless windings has been formulated as a nonlinear programming problem, with motor regulation as an objective function. It is shown that there exists an optimum ratio between electric and magnetic loadings. The optimum parameters are predicted using an efficient direct search method of optimization. It is shown that the design optimization process can result in improved performance. It is also shown that if the drive is operated at optimum speed, the performance can further be enhanced. The numerical results presented pertain to a design with cup-type winding but the approach is equally applicable to other slotless designs and slotted designs

REFERENCES

- [1] Waring R. et al. "An investigation of face type magnetic couplers" Proc. Inst. Of Mech. Engineers, vol.210, , pp 263-272, 1996
- [2] Overshott, K.J. "The comparison of the pull-out torque of p.m. couplings predicted theoretically with experimental measurements" IEEE Trans., Mag-25(5), pp 3913-3915, Sep 1989.
- [3] Ravaud, R.; lemarquand, V.; Lemarquand, G.; "Analytical Design of Permanent Magnet Radial Couplings" IEEE Trans. on Magnetics, 2010.
- [4] Canova A. and Vusini B. "Design of axial eddy-current couplers" IEEE Transactions on industrial applications, vol. 39(3), pp. 725-733, May-June 2003
- [5] Baran, W. "Analytical methods for the design calculations of p.m. synchronous couplings" ACTA Polytechnica Scandinavia, Applied Physics Series, No. 38, Helsinki, pp 13-19, 1983.
- [6] Tawara, Y. et al. "Applications of precipitation-hardened rare-earth cobalt magnets to torque coupling devices" 2nd International Workshop on rare-earth cobalt p.m. and their applications, Dayton, USA, pp 112-123, 1976.
- [7] Hornreich, R.M. and Shtrikman, S. "Optimal design of synchronous torque couplers" IEEE Trans., Mag-14(5), pp 800-802, Sep 1978.
- [8] Yonnet et.al. "Analytical calculation of permanent magnet couplings" IEEE Trans. on Magnetics, vol. 29, No 6, pp 2932-2934, Nov 1993.
- [9] Ferreira, C. and Vaidya, J. "Torque analysis of p.m. couplings using 2D and 3D finite elements methods" IEEE Trans., Mag-25(4), pp 3080-3082, Jul 1989.
- [10] Nagrial, M.H. "Design optimisation of magnetic couplings using high energy magnets" Intl. JI. of Electric Machines and Power Systems. Vol. 21, No. 1, pp 115-126, 1993.
- [11] Nagrial, M.H. "Performance of magnetic couplings using Nd-Fe-B magnets" Proc IEEE Conference "IECON'96" pp. 997-998, Taipei, Taiwan, Aug. 1996.
- [12] Roters, H.C. *Electromagnetic Devices*, John Wiley, 1970.
- [13] Wang, Yu Lin et.al. "Near-optimal design and 3-D finite element analysis of multiple sets of radial magnetic couplings" IEEE Trans. On Magnetics, Vol. 44(12), pp. 4747-4753, Dec 2008
- [14] Wu W., Lovatt H. C. and Dunlop J. B. "Analysis and design optimisation of magnetic couplings using 3D finite element modeling". IEEE Trans., Mag-33 (5), pp 4083-4085, Sep 1997.
- [15] Nagrial, M.H. "Finite element analysis and design of variable reluctance (VR) torque couplers". Proc. International conference on power electronics and drive systems, pp.252-254, vol. 1, 26-29 May 1997.

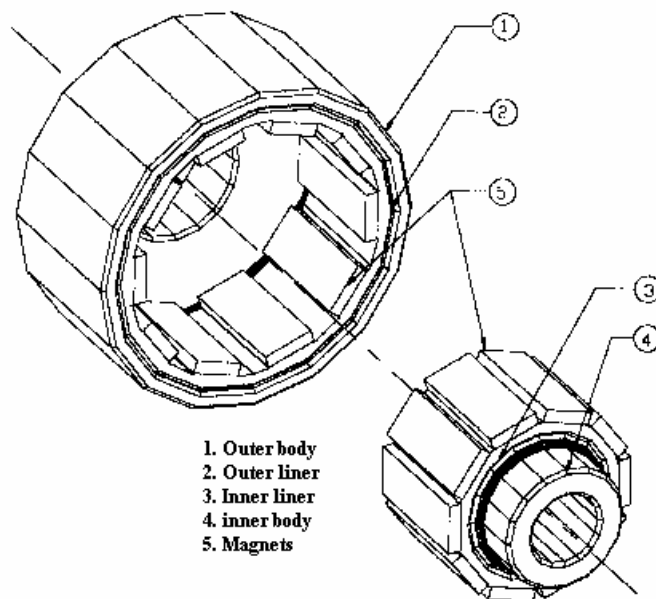

Fig..6 Experimental coaxial coupler (3-dimensions)

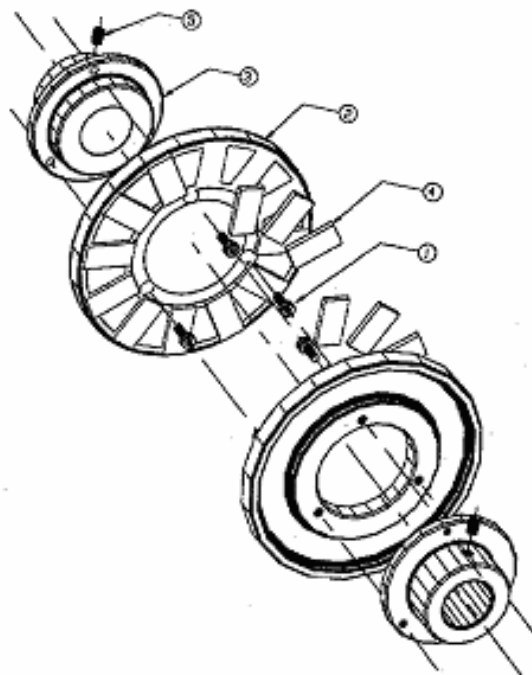

Fig. 7 Experimental axial coupler (3-dimensions)