

# Design of Saddle Support for Horizontal Pressure Vessel

Vinod Kumar, Navin Kumar, Surjit Angra, Prince Sharma

**Abstract**—This paper presents the design analysis of saddle support of a horizontal pressure vessel. Since saddle have the vital role to support the pressure vessel and to maintain its stability, it should be designed in such a way that it can afford the vessel load and internal pressure of the vessel due to liquid contained in the vessel. A model of horizontal pressure vessel and saddle support is created in ANSYS. Stresses are calculated using mathematical approach and ANSYS software. The analysis reveals the zone of high localized stress at the junction part of the pressure vessel and saddle support due to operating conditions. The results obtained by both the methods are compared with allowable stress value for safe designing.

**Keywords**—ANSYS, Pressure Vessel, Saddle, Support.

## I. INTRODUCTION

INDUSTRIAL horizontal pressure vessels are generally structures having complex geometry comprising of various geometrical discontinuities and are commonly required to work under high loading conditions such as external forces, thermal loads, internal pressure etc. The designing and manufacturing of such products are done by the guidelines and codes as per the international standards. Common pressure vessel codes used for designing are ASME Boiler and Pressure Vessel code section VIII, European committee for Standardization and British Standards Institution (unfired fusion Welded Pressure vessels). Horizontally kept cylindrical pressure vessels are generally supported on twin saddle supports. In some cases vessel and saddle support contact is of loose-fitting type. In this case there is a narrow gap or space between the saddle support and vessel, due to which it becomes very difficult for maintenance at that part which causes corrosion. The metal temperature of the pressure vessel is usually different to the ambient conditions during its installation. The differential displacement between the supports due to the temperature change should be considered in design. In a large number of cases the design of support requires adequacy to operate in a severe thermal environment during normal operation as well as to sustain some thermal transients. Usually saddles are welded to the outer periphery of the pressure vessel. In a horizontal pressure vessel with saddle support a high localized stress at the interface of the

vessel and saddle is generated. This highest localized stress is termed as circumferential stress whose intensity is very high at the horn part of the saddle and vessel. ASME boiler and pressure vessel code section VIII, division 2 [1] gives the design rules for supports and attachments used to support the pressure vessel. Ong and Lu [2] suggested a parametric study for determination of optimal support radius of loose-fitting saddle support for cylindrical pressure vessel. They found that the high localized stress arising from saddle support can be reduced by using a clearance - fit saddle support. Parametric formulae were developed and validated with examples. Abbasi et al. [3] carried out a three dimensional finite element analysis of a pressure vessel resting on flexible saddle supports using newly developed thick shell element which takes into consideration the frictional contact between support and the vessel. The results obtained for the vessel and saddle support show that with the increase in saddle radius of 1-2% over the vessel radius results in 50% stress reduction at saddle and vessel junction. An extension of saddle plate by 5-10 degree causes stress reduction of 25 - 40% in both vessel and support. Diamantoudis et al. [4] carried out a comparative study for design by analysis and design by formula of a cylinder to nozzle intersection using different finite element techniques. Zick [5] indicated the approximate stresses that exist in cylindrical vessels supported on two saddles at various locations. He showed that by knowing the stresses, it is possible to know which vessels may be designed for internal pressure alone, and to design structurally adequate and economical stiffening required for the vessels. Zick was first to perform the analysis giving better outcome on the performance. He gave guidelines for saddle design similar to pressure vessel design handbook by E. Megysey. Moss [6] explained the detailed process for designing of horizontal pressure vessel and designing of saddle support for large vessels. Nash et al. [7] explained the design for the horizontal pressure vessel modelled using finite element method. They applied external loads like self-weight, filled liquid weight, and internal pressure to the model. They evaluated and plotted the vessel strain and contact interface pressure which was in line with experimental data. The magnitude of strains at horn is considerably reduced. Spence et al. [8] discussed the various important events occurred over the years in the development of technology of pressure vessels. They recognized the various milestones which stimulated the manufacturing, operation, analysis methods and new equipments regarding pressure vessels depending on many individuals' work. They traced the evolution of codes and standards since industrial revolution. Ong [9] described the analysis of twin saddle supports of cylindrical pressure vessel equally displaced from its ends with loading on the pressure vessel being of symmetric or non-symmetric in nature. He used the approach based on the

Vinod Kumar is with the National Institute of Technology, Kurukshetra - 136118, Haryana, India (phone: +919729030269; fax: +9111744233557; e-mail: mit\_ykum@hotmail.com).

Navin Kumar is with the National Institute of Technology, Kurukshetra - 136118, Haryana, India (phone: +919050384226; fax: +9111744233557; e-mail: navinkumar1612@gmail.com).

Surjit Angra is with the National Institute of Technology, Kurukshetra - 136118, Haryana, India (phone: +919416993047; fax: +9111744233557; e-mail: angrasurjit@yahoo.com)

Prince Sharma is with the National Institute of Technology, Kurukshetra - 136118, Haryana, India (phone: +919467525459; e-mail: prince2605530@gmail.com).

concept of equivalent load method and suggested time saving scheme to cut down computational time. Ong et al. [10] provided a chart consisting of a series of parametric curves to determine the stress reduction. It was found that the saddle support with extended top plate can reduce the peak stress at the support by 50% or more. The chart is shown to be helpful to the designers in deciding the extended plate dimensions. Nash et al. [11] explained the use of Fourier series solution to obtain more accurate stress data. He showed that the effect of flexibility of dished ends of pressure vessel on the maximum stress at horn part of the saddle.

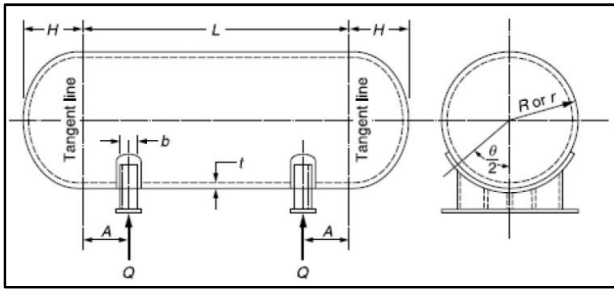

Fig. 1 Saddle dimensions

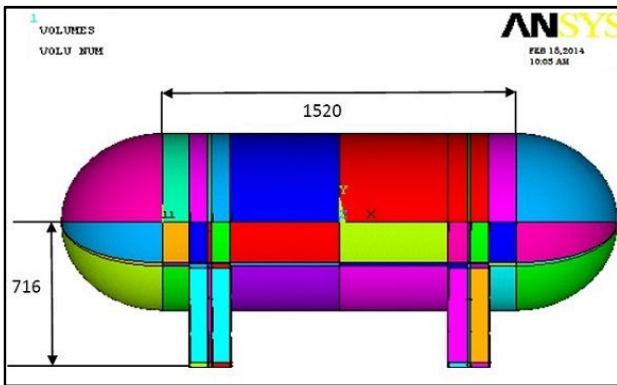

Fig. 2 Front view of vessel

II. VESSEL DIMENSIONS

Vessel Mean Radius (R <sub>m</sub> )	428.64 mm
Stiffened vessel length per 4.15.6 (L)	152.00 cm
Distance from saddle to vessel tangent (A)	203.20 mm
Saddle width (b)	176.00 mm
Saddle bearing angle (Θ)	120 <sup>0</sup>
Inside depth of head (H)	421.28mm
Shell Allowable stress used in Calculation	1407.17 kgf/cm <sup>2</sup>
Head Allowable stress used in Calculation	1407.17 kgf/cm <sup>2</sup>
Circ. Efficiency in plane of saddle (E1)	(1.00)
Circ. Efficiency at Mid-span (E1)	(1.00)
Saddle force, Operating Case (F=Q)	1549 kgf
Rib thickness	16 mm
Base plate thickness	16 mm
Web thickness	16 mm

III. RESEARCH SCHEME

This Analysis extends to find out the stresses generated in the various portions of the vessel and saddle. Stresses are evaluated manually and using ANSYS [12]. The two stresses are then compared. The research work has been focused on the following aspects:

1. Mathematical calculation for the saddle supports.
2. To develop FEM based ANSYS model for vessel and supports.
3. Comparison of the manual result with ANSYS results.

TABLE I  
MATERIAL ATTRIBUTES

Material	ρ	E	σ <sub>y</sub>	v
SA516 Gr70	7750	192	260	0.3

IV. MATHEMATICAL APPROACH

The cylindrical shell acts as a beam over the two supports to resist bending by the uniform load of the vessel and its contents. The total weight of the vessel and its contents is equal to 2Q. If the vessel is composed of a cylindrical shell with a formed head (i.e. torispherical, elliptical, or hemispherical) at each end that is supported by two saddle supports equally spaced and with  $A \leq 0.25 L$ , then the moment at the saddle, M<sub>1</sub>, the moment at the centre of the vessel, M<sub>2</sub>, and the shear force at the saddle, T, may be computed using the following equations [1]:

$$M_1 = -Q \times A \times \left( 1 - \frac{A}{L} + \frac{R^2 - H^2}{2 \times A \times L} \right) \div \left( 1 + \frac{4}{3} \frac{H}{L} \right)$$

$$M_2 = \frac{Q \times L}{4} \times \left( \frac{1 + \frac{2 \times (R^2 - H^2)}{L^2}}{1 + \frac{4}{3} \frac{H}{L}} - 4 \times \frac{A}{L} \right)$$

$$M_1 = -1549 \times 203.2 \times \left( 1 - \frac{203.2}{152} + \frac{428.64^2 - 421.28^2}{2 \times 203.2 \times 152} \right) \div \left( 1 + \frac{4}{3} \times \frac{421.28}{152} \right) = -113.3 \text{ kgf-m}$$

$$M_2 = \frac{1549 \times 152}{4} \times \left( \frac{1 + 2 \times \left( \frac{428.64^2 - 421.28^2}{152^2} \right)}{1 + \frac{4}{3} \times \frac{421.28}{152}} - 4 \times \frac{203.2}{152} \right) = 117.4 \text{ kgf-m}$$

The longitudinal membrane plus bending stresses in the cylindrical shell between the supports are given by the following equations. Longitudinal stress at top of the shell:

$$\sigma_1 = \frac{P \times R_m}{2 \times t} - \frac{M_2}{\pi \times R_m^2 \times t}$$

$$\sigma_1 = \frac{8.45 \times 428.64}{2 \times 14.72} - \frac{117.4}{\pi \times 428.64^2 \times 14.72} = 121.61 \text{ kgf/cm}^2$$

Longitudinal stress at the bottom of the shell:

$$\sigma_2 = \frac{P \times R_m}{2 \times t} + \frac{M_2}{\pi \times R_m^2 \times t}$$

$$\sigma_2 = \frac{8.45 \times 428.64}{2 \times 14.72} + \frac{117.4}{\pi \times 428.64^2 \times 14.72} = 124.32 \text{ kgf/cm}^2$$

Longitudinal stress at top of Shell at supports:

$$\sigma_3 = \frac{P \times R_m}{2 \times t} - \frac{M_1}{\pi \times R_m^2 \times t}$$

$$\sigma_3 = \frac{8.45 \times 428.64}{2 \times 14.72} - \frac{-113.3}{\pi \times 428.64^2 \times 14.72} = 124.32 \text{ kgf/cm}^2$$

Longitudinal stress at the bottom of the shell at support

$$\sigma_4 = \frac{P \times R_m}{2 \times t} + \frac{M_1}{\pi \times R_m^2 \times t}$$

$$\sigma_4 = \frac{8.45 \times 428.64}{2 \times 14.72} + \frac{-113.3}{\pi \times 428.64^2 \times 14.72} = 121.66 \text{ kgf/cm}^2$$

T is the total shear force induced on the saddle support and it is determined by the following equation:

Maximum shear force in the saddle

$$T = \frac{Q \times (L - 2 \times A)}{L + \frac{4}{3}H} = \frac{1549 \times (152 - 2 \times 20.32)}{152 + \frac{4}{3} \times 421.28} = 828.7 \text{ kgf}$$

### V. FINITE ELEMENT ANALYSIS

SOLID45 is used for the three dimensional modeling of solid structures. The element is defined by eight nodes having three degrees of freedom at each node i.e. translations in the nodal x, y, and z directions. The finite element model consists of Saddles, hemispherical heads and cylindrical shell. The finite element model has been plotted and meshed model is shown in Figs. 3 and 4.

The loads are applied as pressure on the inside area of vessel. The pressure applied is 0.824E+6 N/m<sup>2</sup>. Gravitational acceleration is applied in the global -Y directions, which also consider the weight of content inside the vessel, for which equivalent density was used.

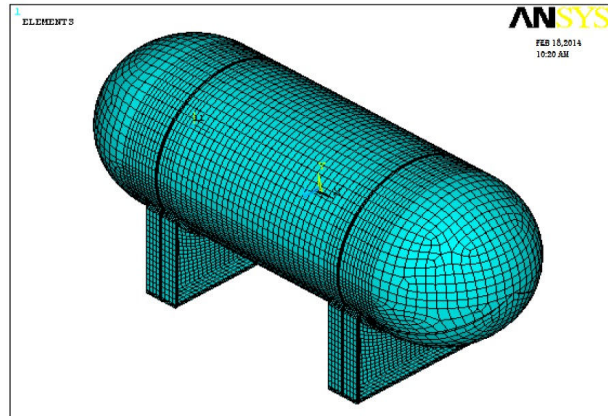

Fig. 3 Meshed Model

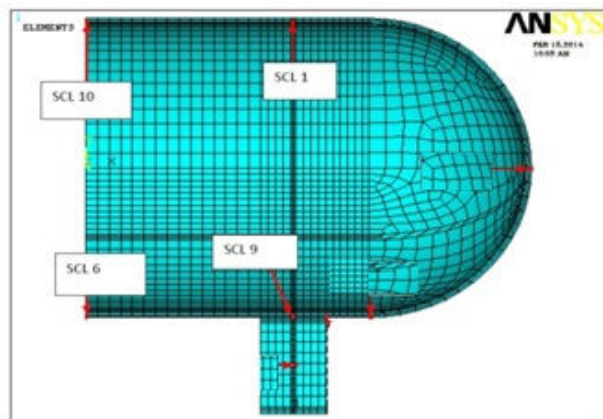

Fig. 4 Locations of stress classification line

### VI. RESULT ANALYSIS

The Von-Mises stress distribution is shown in Fig. 5. The different stress intensities are observed across the junction. Location of the stress classification lines are shown in Fig. 4.

The linearized results at different location on the vessel are plotted as graph i.e., Fig. 6 shows scl 10 linearized stress plot.

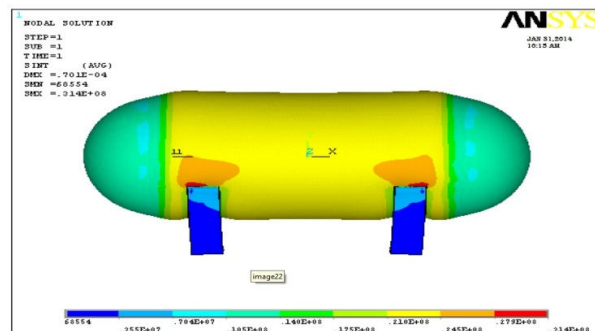

Fig. 5 Intensities of von mises stresses across junctions

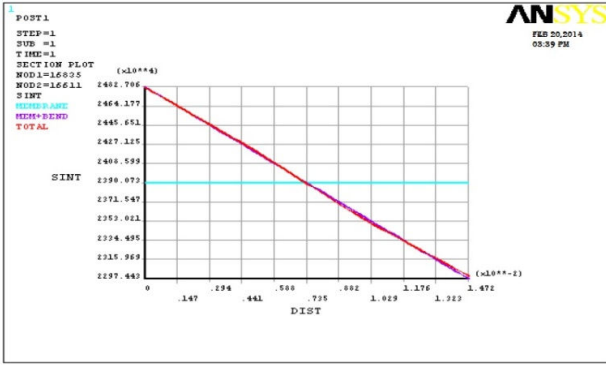

Fig. 6 Scl 10 linearized stress plot

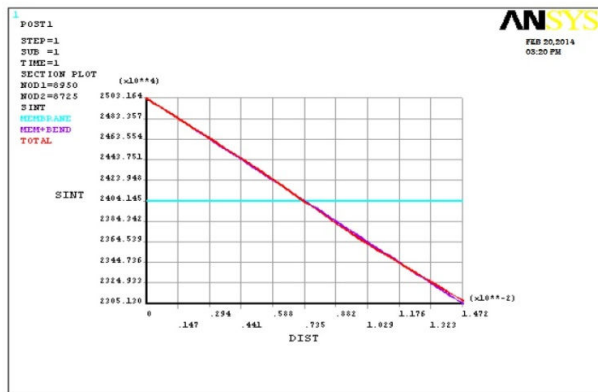

Fig. 7 Scl 6 linearized stress plot

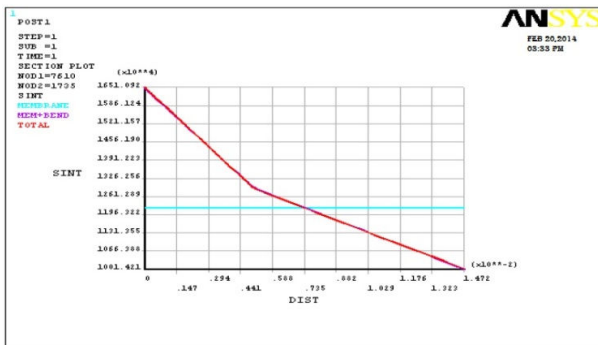

Fig. 8 Scl 9 linearized stress plot

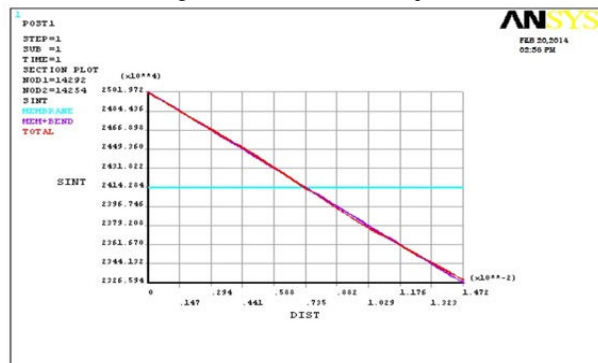

Fig. 9 Scl 1 linearized stress plot

The stress classification line for the different part of the pressure vessel and saddle support are shown in the meshed model and the distribution of the stresses at these locations corresponding to the thickness of the vessel are plotted in the above graphs shown in the Figs. 6-9, which are obtained by the analysis of the horizontal pressure vessel and its saddle support.

TABLE II  
COMPARISON OF STRESSES

Sr. No.	Stress Location and Type	Scl	Manual Result (kgf/cm <sup>2</sup> )	ANSYS Result (kgf/cm <sup>2</sup> )	Allowable Stress (kgf/cm <sup>2</sup> )
1	$\sigma_1$	Scl 10	121.61	110.63	1407.17
2	$\sigma_2$	Scl 6	124.32	107.47	1407.17
3	$\sigma_3$	Scl 1	124.32	113.59	1407.17
4	$\sigma_4$	Scl 9	121.61	109.21	1407.17

VII. CONCLUSION

Comparative study of the stresses obtained by ANSYS software and mathematical approach shows that stress calculated by ANSYS is less than that by mathematical approach and also less than allowable stresses. It has been found that the present design is safe. The stresses in vessel and saddle support at different locations are shown in Table II. Fig. 10 shows the comparison of result for the manual calculation and ANSYS Software. It is found that manual results are on conservative side whereas ANSYS provides the actual result.

It has been analyzed that by doing adequate modifications in the present design we can further reduce maximum stress value at critical zone, optimize the cost for equipment and these modifications are given as:

- (i) designing the saddle in such a way it should be flexible at the saddle horn.
- (ii) by inserting a wear plate between saddle and vessel.
- (iii) by making saddle support radius little bit greater than vessel outer radius.

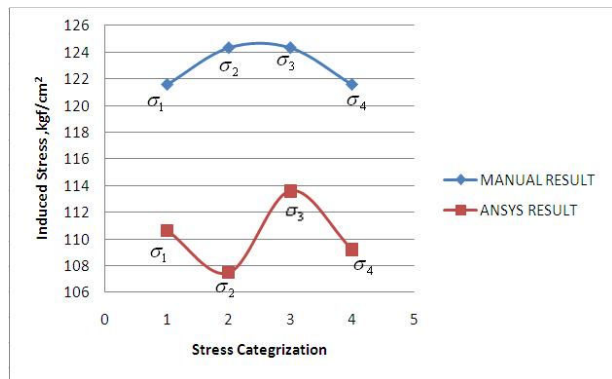

Fig. 10 Comparison Manual v/s ANSYS Result

APPENDIX

- $\rho$  = Density of material, kg/m<sup>3</sup>
- E = Modulus of elasticity, GPa.
- $\sigma_y$  = Yield strength of the material, MPa.

$\nu$  = Poisson Ratio

$R_m$  = radius of the pressure vessel, mm.

$L$  = length of the P.V. from tangent to tangent line, mm.

$A$  = distance between saddle Centre and tangent line, mm.

$b$  = width of the base plate, mm.

$t$  = thickness of shell, mm.

$Q$  = Maximum reaction load at the saddle, kgf or N.

$\sigma_1, \sigma_2$  = Longitudinal stresses in the shell at top and bottom of mid span, kgf/cm<sup>2</sup>.

$\sigma_3, \sigma_4$  = Longitudinal stress at top and bottom of saddle, kgf/cm<sup>2</sup>.

$M_1$  = Maximum longitudinal bending moment at the saddle, N-m or kgf-m.

$M_2$  = Maximum longitudinal bending moment between the saddle supports, N-m or kgf-m.

$\Theta$  = angle of contact of saddle with shell, degree.

$E_1$  = Joint efficiency

Circ. = Circumferential

#### REFERENCES

- [1] "ASME Boiler and Pressure Vessel Code," Section VIII, Pressure Vessels Division, 2. ED2010.
- [2] L.S.Ong and G.Lu, "Optimal support radius of loose-fitting saddle," *International Journal of Pressure Vessels & Piping*, vol.54, pp. 465-479, 1993.
- [3] N.El-Abbasi, S.A. Maguid and A. Czekanski "Three dimensional finite element Analysis of saddle supported pressure vessel," *International journal of mechanical sciences*, vol. 43, pp. 1229-1242, 2001.
- [4] A.Th.Diamantoudis and Th. Kermanidis, "Design by analysis versus design by formula of high strength steel pressure vessel a comparative study," *international Journal of Pressure Vessels & Piping*, vol.82, pp. 43-50, 2005.
- [5] Zick L.P, "Stresses in large horizontal cylindrical Pressure vessel on two saddle supports," *The welding Research Supplement*, pp.959-970, 1971.
- [6] Dennis. R. Moss, *Pressure Vessel Design Manual Third edition*, 2004, pp. 166-184.
- [7] D. H. Nash, W. M. Banks and F. Bernaudon, "Finite Element Modeling of Sling-Supported Pressure Vessels," *Thin-Walled Structures*, Vol. 30, nos. 1-4, pp. 95-110, 1998.
- [8] J. Spence, D.H. Nash, "Milestones in pressure vessel technology," *International Journal of Pressure Vessels and Piping*, vol.81, pp. 89-118, 2004.
- [9] Ong Lin Seng, "Analysis of Twin-Saddle-Supported Vessel Subjected to Non-Symmetric Loadings," *International Journal of Pressure Vessels and Piping*, vol. 35, pp. 423-437, 1988.
- [10] L. S. Ong & G. Lu, "Stress reduction factor associated with saddle support with extended top plate," *international journal of pressure Vessel & Piping*, vol. 62, pp. 205-208, 1995.
- [11] David H Nash and Alwyn S Tooth, "The influence of the flexibility of the dished end on twin saddle supported pressure vessels," *the ASME eighth international conference on pressure vessel technology, Montreal, Quebec, Canada*, pp. 475-480, 1996.
- [12] ANSYS 14.0 Release.