

Design and Simulation of Portable Telemedicine System for High Risk Cardiac Patients

V. Thulasi Bai, and Srivatsa S. K.

Abstract—Deaths from cardiovascular diseases have decreased substantially over the past two decades, largely as a result of advances in acute care and cardiac surgery. These developments have produced a growing population of patients who have survived a myocardial infarction. These patients need to be continuously monitored so that the initiation of treatment can be given within the crucial golden hour. The available conventional methods of monitoring mostly perform offline analysis and restrict the mobility of these patients within a hospital or room. Hence the aim of this paper is to design a Portable Cardiac Telemedicine System to aid the patients to regain their independence and return to an active work schedule, there by improving the psychological well being. The portable telemedicine system consists of a Wearable ECG Transmitter (WET) and a slightly modified mobile phone, which has an inbuilt ECG analyzer. The WET is placed on the body of the patient that continuously acquires the ECG signals from the high-risk cardiac patients who can move around anywhere. This WET transmits the ECG to the patient's Bluetooth enabled mobile phone using blue tooth technology. The ECG analyzer inbuilt in the mobile phone continuously analyzes the heartbeats derived from the received ECG signals. In case of any panic condition, the mobile phone alerts the patients care taker by an SMS and initiates the transmission of a sample ECG signal to the doctor, via the mobile network.

Keywords—WET, ECG analyzer, Bluetooth, mobile cellular network, high risk cardiac patients.

I. INTRODUCTION

CARDIOVASCULAR disease is the world's leading killer, accounting for 16.7 million or 29.2 per cent of total global deaths. With modernization, a large proportion of young people are trading healthy traditional diets for fatty foods. Also most of them are employed with deskbound sloth nature of jobs that lacks any physical exercise. They also lead a stressful city life when compared to the relative calm of the countryside. These risk factors contribute to an alarming increase in high-risk cardiac patient population [1]. Hence it becomes essential to monitor and alert the near ones of the patient and his family physician about the fatal condition that may occur at any instant.

Manuscript received September 5, 2006.

V. Thulasi Bai is with the Satyabama Institute of Science and Technology as Research Scholar and Asst.Professor at Sri Sai Ram Engineering College, Chennai, TamilNadu, India (phone: 91 44 22276905; e-mail: thulasi_bai@yahoo.com).

S. K. Srivatsa is with Electronics Department, St.Josephs College of Engineering, Chennai, TamilNadu, India (e-mail: profsks@rediffmail.com).

Generally all monitoring systems are available for bedridden patients. All mobile telemedicine systems that have been designed so far have telemedicine systems that samples the medical data acquired, stores it for a short duration and then transmits to the doctor end [2],[3]. That is they are available only for monitoring and do not alert the doctor or the near ones about the panic situation of the patient. Different monitoring systems are commercially available and some of the research proposals about monitoring systems are classified in respect of the following features [4].

- *Systems that record signals and perform analysis off-line.* These systems only record the vital signals and no real time classification is done E.g. Holters, Medtronic Reveal Insertable Loop recorder.
- *Systems that perform remote real time monitoring.* Here the ECG signals are captured and sent to a monitoring centre through mobile phones. The limitation here is that the analysis is not performed in the place where the signal is acquired. E.g. Vita phone[5], QRS diagnostic, Cardio control, MobiHealth Project.
- *Systems that provide local real-time classification.* These systems use intermediary local computers between sensors and the control centres or a hospital. These computers perform local real time monitoring. If some anomalies are detected, it sends alarms to the hospital. E.g.@Home[6], TeleMediCare and PhMon [7].

In those systems that make use of PCs to perform local real-time analysis, the mobility area of the patients is not very large. It is almost reduced to their homes. Hence we propose a telemedicine system that monitors, performs real time analysis with the mobile phone and alerts the physician about the fatal condition. Also both the patient and the doctor can be mobile. This system maximizes the ability of cardiac patient to regain their independence and move freely.

II. OVER VIEW OF LOCAL REAL-TIME CARDIAC TELEMEDICINE SYSTEM

Fig. 1 shows the overview of the local real time monitoring system using mobile phone. The system consists of four subsystems namely:

1. Signal such as ECG, blood pressure and body temperature are normally used to monitor a patient. Out of these signals we acquire only the ECG of the patient using miniature wearable chest equipment termed Wireless ECG Transmitter (WET). These signals are amplified, conditioned and transmitted to the mobile phone which is blue tooth enabled.
2. The mobile phone has an in built ECG analyzer. It receives the ECG signal and processes it and calculates the heart rate of the patient in beats per minute (bpm).
3. This output in bpm is fed to a microcontroller. The ECG analyzer and microcontroller are designed to be present inside the mobile phone. The microcontroller declares panic situation in any of the following cases:
 - ❖ The beat per minute value is not between 60 and 100.
 - ❖ Relatively fluctuating bpm for every heartbeat.
 - ❖ The R-amplitude falls below the minimum required by a healthy heart.

Once the panic situation is declared by the microcontroller, the panic switch is closed and the automatic call function is triggered. Hence, the mobile phone establishes contact with the nearest medical center's server.

4. Only under panic condition, one minute sample of ECG signal of the patient is sent via the mobile network to the doctor using GPRS and an alerting SMS is given to the caretaker.

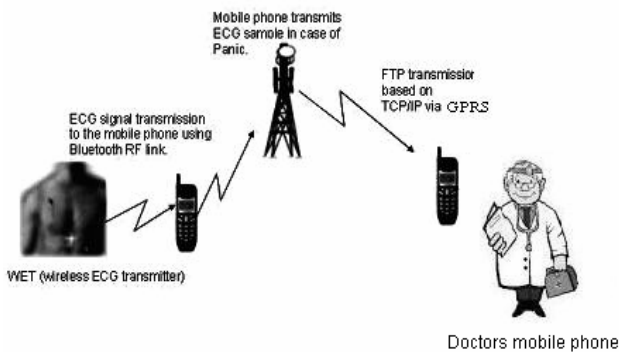

Fig. 1 Overview of wireless ECG transmission & analysis

III. DESIGN OF WIRELESS ECG TRANSMITTER (WET)

In simple terms, the WET is a wearable, miniature, chest equipment that is portable and fitted on the patient. The ECG electrodes acquire the ECG signals and an instrumentation amplifier amplifies it. In order to make the processing easier the frequency of the signal is raised audio frequency range by a multiplier section. After analog to digital conversion, these

ECG signals are transmitted to a mobile phone via blue tooth link. Fig. 2 illustrates the internal blocks of the WET. For the patients suffering from cardiac diseases it is very important to perform accurate and quick diagnosis. For this purpose a continuous monitoring of the ECG signal and the patient's current heart activity are necessary.

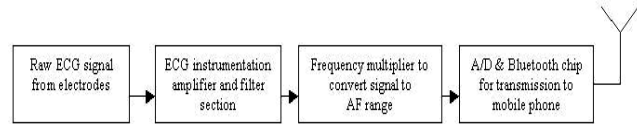

Fig. 2 Essential blocks of the WET

A. Amplifier & Filter Section

The ECG electrodes continuously tap the ECG signal from the patient's body. The raw ECG signal's amplitude lies in the range of 0.1mV to 2mV that needs to be amplified for further processing. Its frequency range is between 0.5Hz to 250Hz. The instrumentation amplifier serves as a pre-amplifier with a gain of 50. This pre-amplified signal is fed to a high pass filter with a cut off frequency of 0.5Hz. It is then followed by a post-amplifier of gain 10 and a low pass filter of cut off frequency of 250Hz. Hence, the high pass filter and the low pass filter together serve as a band pass filter limiting the frequency between 0.5Hz to 250Hz. After pre and post amplification the signal is amplified 500 times.

B. Frequency Multiplier

The amplified ECG signal lies in the extremely low frequency range (0.5Hz to 250Hz). Hence multiplying it to the audio frequency range will make processing and transmission of the signal easier. For instance, a PLL frequency multiplier can be utilized to accomplish such a task. PLL multipliers circuits operation is typical of all phase locked loops. Since the entire ECG signal ranges from 0.5Hz to 250Hz, this frequency will be multiplied by a factor of 80 such that it is in the audio frequency range. Thus the multiplied signal will be in the range of 40Hz to 20 kHz. This audio frequency signal can be easily processed and transmitted.

C. The Bluetooth Transmission

Short-Range Wireless (SRW) networks such as Blue tooth technology, RFID and IR, are gradually becoming more and more widespread in modern information systems [8]. Most of these SRW networks have some drawbacks as the transmitting distance is less or else they are prone to disturbance due to outside environment. The most feasible of them is, the blue tooth as it has the essential ingredients whether it is the data rate or the error rate at which it transmits. Also studies indicate that blue tooth technology is electro magnetically compatible with the tested medical devices [9]. Hence we propose to use blue tooth link between the WET and ECG Analyzer.

Blue tooth (IEEE 802.15) is a universal short range low-power radio protocol operating in the unlicensed industrial, scientific and medical frequency band. It allows both data and

voice transmission. The modulation technique is GFSK (Gaussian Frequency Shift Keying), with transmission at a rate of 1M symbols/s on one of 79 channels with 1MHz spacing in the 2.402GHz-2.480 GHz band [10]. Blue tooth uses the spread-spectrum frequency hopping connection with a rate of 1600 hops/s. Its key features are robustness, low complexity, low power and low cost [11]-[14]. Compared to other methods of transmission, Bluetooth facilitates a noise free transmission. Moreover privacy and security options are highly advanced in the case of Bluetooth. We have used BR-C29 (Blue Radios – 32 pin Bluetooth transceiver chip), which is a single chip solution for Bluetooth transmission. This chip requires an unregulated power supply of 1.9V-3.4V for its operation.

Antennas need to be connected externally to the chip as shown in the Fig. 3. The transceiver chip serves both as a transmitter and a receiver. However, the mode of communication between the WET and the mobile phone is of the type simplex. Hence, the job of the Bluetooth transceiver situated in the WET is only to transmit. The transmitter starts with base band GFSK modulation data, which passes through a Gaussian filter. GFSK is a modulation technique where the data change the frequency of the carrier linearly for some amount of a carrier cycle during the duration of a bit. The rate of frequency change is a function of the data rate. The amount of the frequency change is a function of the amplitude of the data. Hence, in this piconet, the WET plays the master and the mobile phone plays the slave.

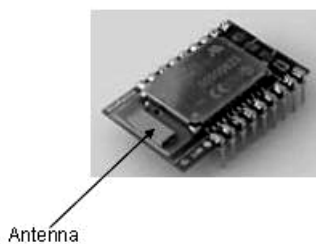

Fig. 3 BR-C29 Bluetooth Transceiver Chip

IV. MOBILE ECG ANALYZER

The analyzing circuitry for the ECG signal is present inside the mobile phone. The transmitted ECG signal from the WET is received by the blue tooth enabled mobile phone, via bluetooth link. Fig. 4 shows the essential blocks of the Mobile ECG Analyzer.

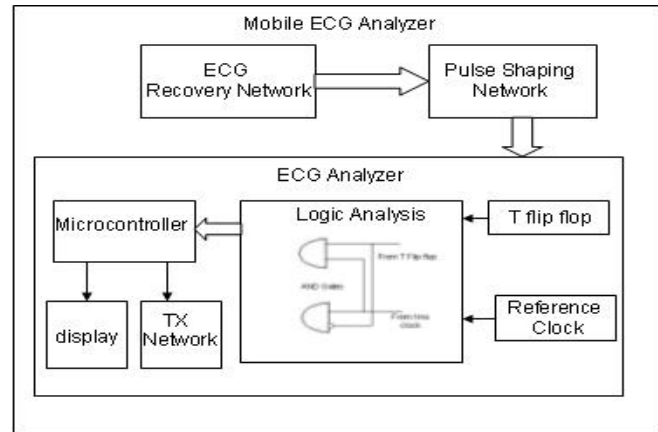

Fig. 4 Essential blocks of Mobile ECG Analyzer

The reverse process of the operations performed at the transmitting end, brings back the very same observed ECG signal. Hence, the operations like demodulation, D/A conversion and frequency division by a factor of 80, have to be performed. Thus, the WET and mobile phone are synchronous with each other. This recovers back the originally observed ECG signal. The analyzer circuit checks the most significant parameter: the R-R interval of the PQRS waves used to find the bpm (beats per minute). To find the R-R interval of the PQRS wave, the fact that the R wave is the most sharp, narrow and steep section of the wave, will be exploited. Moreover, the R section of the wave is the most sensitive one and any heart irregularity will instantly reflect on the R wave with great prominence. In order to measure the time interval between two R waves, focus is given on the upper halves of the R waves.

Once the original ECG signal is recovered after demodulation and frequency division, it is fed to a negative clipper circuit with positive V_{ref} . The V_{ref} is fixed at a value which is equal to the medically approved minimum R amplitude for a healthy heart. Consequently, a train of R pulses above the zero axis by a amount of $+V_{ref}$ is obtained. In order to coincide this train of pulses with the zero axes, it is necessary to clamp the signal by using a negative clamper circuit with negative V_{ref} . This gives a train of R pulses based on zero voltage reference axes. This is fed to a Schmitt trigger circuit whose output will be a train of voltage pulses.

These voltage pulses can be used as gate open and gate close pulses wherein the gate will preferably be a T-flip flop, as shown in Fig. 5. The rectangular pulses from the T-flip flop are fed to two AND gates. The pulse fed to the second AND gate is going to be an inverted one. Thus the first AND gate is enabled when the rectangular pulse is high, and the second one is enabled only when the rectangular pulse is low. It is to be noted that the pulse width gives the R-R interval. The main job of the T-flip flop is to convert the time periods into pulse widths. A clock pulse of 1 ms time period is fed simultaneously to both the AND gates. Hence the counter A and the counter B count the clock pulses in alternate fashion

depending upon the enabling of the AND gates. The main idea behind using two counters is to avoid time delays such as transfer of counter output to microcontroller, set-reset time, etc. The counter output will be the number of clock pulses passed through the gate within an R-R interval. The microcontroller uses the below shown simple calculation to find the bpm (beats per minute).

$$\text{Beats per minute (bpm)} = \frac{60}{(N * 1 \text{ msec})}$$

where, N is the number of clock pulses counted by the respective counter. 1 ms is the time period of the clock pulse. For example: if N= 800 then bpm = 60/ (800*1ms) = 75 bpm, which is a normal bpm value.

V. LOGICAL ANALYSIS OF ECG

Any symptom of heart attack instantaneously reflects upon the R-R interval. Based on the ECG signal received the ECG analyzer calculates the heart rate in beats per minute. From this value obtained, analysis is done to verify whether the patient has a possibility of heart attack. The symptoms of heart attacks can be broadly classified into two types namely Tachycardia and Bradycardia [15]. Fig. 5 shows the logic of the ECG analysis performed by the mobile ECG analyzer.

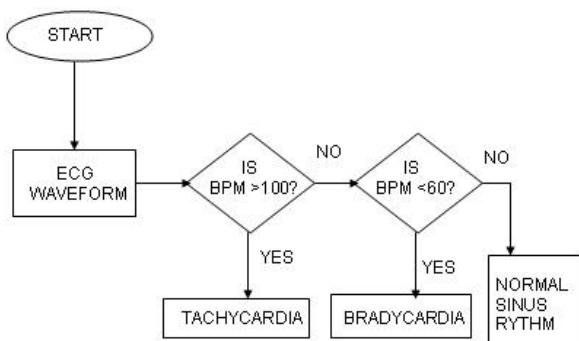

Fig. 5 Flowchart showing the logic of ECG analysis

When the bpm is above 100, it is said to be a tachycardia symptom. On the other hand, if the bpm falls below 60, it is said to be a bradycardia symptom. Thus the bpm value for the normal sinus rhythm ranges between 60 and 100, i.e., normally the R-R interval should range between 600ms and 1000ms. The mobile phone's microcontroller declares panic situation in any of the following cases:

1. The beat per minute value is not between 60 and 100.
2. Relatively fluctuating bpm for every heartbeat.
3. The R-amplitude falls below the minimum required by a healthy heart.

The mobile number of the doctor and the caretaker of the patient are stored in the microcontroller. Once the panic situation is declared by the microcontroller, the panic switch is closed and the automatic call function is triggered. The mobile phone establishes contact to the doctor by sending one-minute sample of ECG signal and an alerting SMS to the caretaker.

VI. TRANSMISSION OF ECG SAMPLE TO DOCTOR

Modern mobile communications are based on GSM and GPRS. GSM in standard mode of operation provides a data rate of 9.6kbps. Whereas GPRS supports a data rate of 171.2kbps has performance superior to GSM. Further it has been shown that the method of using FTP over GPRS was by far superior to email [16]. GPRS (General packet radio services) is a packet based wireless communication service that offers continuous connection, higher capacity mobile data services such as Internet/WAP, browsing email on the move, powerful visual communications, multimedia messages and location based services [17]. GPRS packet transmission offer a more user friendly billing than that offered by circuit switched services. Based on the above factors we proposed to send ECG transmissions using FTP via GPRS.

Once the panic situation is declared and link has been established with the doctor's mobile phone using GPRS, the mobile phone of the patient transmits a one-minute sample of ECG signal via the mobile cellular network. The transmission of the ECG signal can be considered similar to the transmission of a digitized voice signal over a mobile cellular network.

VII. RESULTS AND DISCUSSION

The complete wearable telemedicine processor, now at a prototype stage has been tested for acquiring and transmitting the ECG signal to the ECG analyzer. The designed WET was able to successfully transmit the ECG signals through blue tooth dongle. For test purpose the ECG analyzer was simulated using MATLAB in a PC. The ECG received by the blue tooth enabled PC was given as input to the simulated ECG analyzer. The ECG analyzer was tested for both tachycardia and bradycardia symptoms.

Fig. 6 shows the simulation that was performed for Bradycardia condition, where the heart beat falls below 60 beats/minute. The microcontroller successfully initiated a call function for both tachycardia and bradycardia conditions. The blue tooth link between the WET and mobile phone eliminates cumbersome cables and enables absolutely free mobility to the patient. More over, blue tooth has high privacy and security features, which eliminates any chance of user collision and interference.

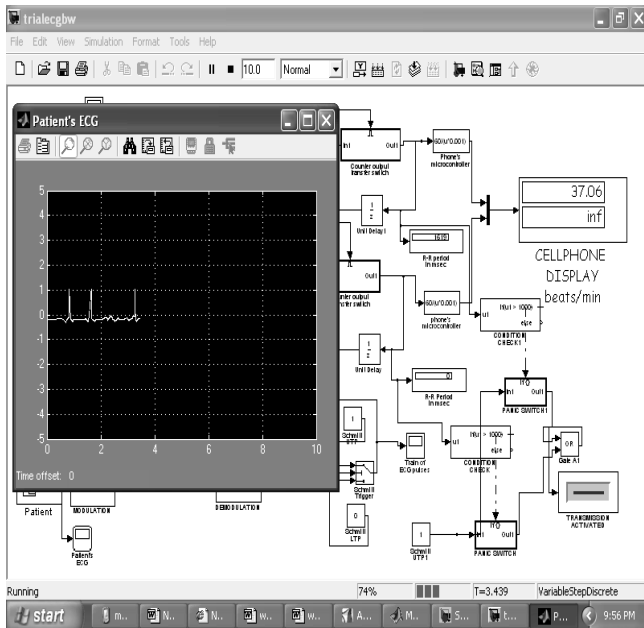

Fig. 6 Simulation of WET and Mobile ECG Analyzer

VIII. CONCLUSION

Monitoring systems that perform a complete ECG analysis in a local device near the patients are of great interest because they allow us to improve the quality of life for those who suffer from cardiac disorders. For 'an anywhere at anytime' monitoring system, devices used have to be actually mobile. Hence, we recommend the usage of mobile phones as the core of these kinds of monitoring systems. In this paper, we have presented how WET and ECG analyzer in the mobile phone, proves to be a life-saving tool for cardiac patients. As a future enhancement, we recommend the usage of GPS & GIS for effective rescue of patient from any location by an ambulance in any case of cardiac emergency.

REFERENCES

- [1] Dr. Rajesh Pande, "Cardiovascular disease in India and impact of lifestyle and food habits," in *Express Health Care Management Magazine*, 15th Dec, 2004.
- [2] B.Woodward, R.S.H.Istepanian and C.I.Richards, "Design of Telemedicine system using a mobile Telephone," *IEEE Trans. inf. Tech in Biomedicine*, vol.5, no.1, march 2001, pp13-15.
- [3] Mohd Fadlee A. Rasid and Bryan Woodward, "Bluetooth telemedicine processor for multichannel biomedical signal transmission via mobile cellular networks," *IEEE Trans. inf. Tech in Biomedicine*, vol .9, no.1, 2005 pp.35-43.
- [4] Jimena Rodriguez, Alfredo Goni, and Arantza Illaramendi, "Real-time classification of ECGs on a PDA," *IEEE Trans. inf. Tech in Biomedicine*, vol .9, no .1, 2005, pp 23- 34.
- [5] N.Daja, I.Reljin and B.Reljin, "Telemonitoring in cardiology-ECG transmission through mobile phones ," *J.Annals Academy Studenica*, vol4, 2001, pp.63-66.
- [6] I.Sachpazidis, "@ Home: A modular telemedicine system," in *Proc. 2nd Workshop Mobile Computing in Medicine*, Germany, 2002.
- [7] C.Kunze, U.Grossmann, W.Stork, and K.D.Muller-Glaser, "Application of ubiquitous computing in personal health monitoring systems," in *Proc.36th Annu.Meeting German Society for Biomed. Eng.*, 2002, pp.360-362.
- [8] P.Bauer, M.Sichitiu, R.Istepanian and K.Premaratne , "The Mobile Patient: Wireless Distributed Sensor Networks for patient monitoring and Care," in *Proc. IEEE EMBS International Conference on Information Technology Applications in Biomedicine*, Arlington, pp.17-21, 2000.
- [9] Mats K. E. B. Walling MD, MSc t, and Samson Wajtraub, MSc t, "Evaluation of Bluetooth as a Replacement for Cables in Intensive Care and Surgery," *Critical Care and Trauma, Technical Communication*, September 8, 2003.
- [10] Nathan. J. Muller, *Bluetooth Demystified*. Mc.Graw Hall Edition, 2000.
- [11] William Brims, *Wireless ECG*. vol .1 [Online]. Available: <http://innovexpo.itee.uq.edu.au/2002/projects/s354005/thesis.pdf>
- [12] Haroon Mustafa Khan, *Wireless ECG*. vol .2. [Online]. Available: <http://innovexpo.itee.uq.edu.au/2002/projects/s358223/thesis.pdf>.
- [13] Bhavik Kant. *Wireless ECG*. vol .3 [Online]. Available: <http://innovexpo.itee.uq.edu.au/2002/projects/s354155/thesis.pdf>
- [14] Brian Sense, "Implementing wireless communication in hospital environments with Bluetooth, 802.11b, and other technologies".
- [15] Patrick O. Bobbie, Hema Chaudhari and Chaudary-Zeeshan Arif, Homecare Telemedicine: Analysis and Diagnosis of Tachycardia Condition in an M8051 microcontroller. [Online]. Available: http://cse.spsu.edu/pbobbie/New_pdf/ECG-Paper-.pdf.
- [16] S. Ch.Voskarides, C.S.Pattichis, R.Istepanian, "Practical evaluation of GPRS use in Telemedicine System in Cyprus," in *Proc. 4th Conf on Inf.Tech Applns. In Biomedicine*, U.K.2003, pp39-42.
- [17] GSM webpage: [http:// www.gsmworld.com](http://www.gsmworld.com).