

Design and Simulation of Air-Fuel Ratio Control System for Distributorless CNG Engine

Ei Ei Moe, Zaw Min Aung and Kyawt Khin

Abstract—This paper puts forward one kind of air-fuel ratio control method with PI controller. With the help of MATLAB/SIMULINK software, the mathematical model of air-fuel ratio control system for distributorless CNG engine is constructed. The objective is to maintain cylinder-to-cylinder air-fuel ratio at a prescribed set point, determined primarily by the state of the Three-Way-Catalyst (TWC), so that the pollutants in the exhaust are removed with the highest efficiency. The concurrent control of air-fuel under transient conditions could be implemented by Proportional and Integral (PI) controller. The simulation result indicates that the control methods can easily eliminate the air/fuel maldistribution and maintain the air/fuel ratio at the stoichiometry within minimum engine events.

Keywords— Distributorless CNG Engine, Mathematical Model of Air-fuel control, MATLAB/SIMULINK, PI controller

I. INTRODUCTION

THE Air-Fuel Ratio control is one of the most important control problems for conventional gasoline engines. The AFR control performance can strongly impact key vehicle attributes such as emissions, fuel economy and drivability. For instance, the AFR in engine cylinders must be controlled in such a way that the resulting exhaust gases can be efficiently converted by the Three-Way Catalyst (TWC). The TWC efficiency is about 98 percent when the fuel is matched to air charge in stoichiometric proportion. [1]

The TWC can also compensate for the temporary AFR deviation from stoichiometry, by either storing excess oxygen or releasing oxygen to convert excess hydro-carbons (HC) and carbon monoxide (CO). Thus, for the TWC to operate efficiently, the stored oxygen level must be regulated so that a range to accommodate further release or storage during transient conditions is available. The oxygen storage level in the TWC may be inferred on the basis of the TWC model and

Ei Ei Moe is with the Department of Electronic Engineering and Information Technology, Yangon Technological University, YTU Campus, Gyogone, Insein Township, Yangon, Myanmar (corresponding author to provide phone: 00-95-1-534283; e-mail: moe.eiei@gmail.com).

Dr. Zaw Min Aung is with the West Yangon Technological University, WYTU Campus, Hlaingtharyar Township, Yangon, Myanmar (e-mail: zawminaung@gmail.com).

Dr. Kyawt Khin is with the Department of Electronic Engineering and Information Technology, Yangon Technological University, YTU Campus, Gyogone, Insein Township, Yangon, Myanmar (e-mail: kyawtkhin@gmail.com).

a signal from a switching Exhaust Gas Oxygen (EGO) sensor located downstream of the TWC. [2, 3]

The EGO sensor works like a miniature generator and produces its own voltage when it gets hot. Inside the vented cover on the end of the sensor that screws into the exhaust manifold is a zirconium ceramic bulb. The bulb is coated on the outside with a porous layer of platinum. Inside the bulb are two strips of platinum that serve as electrodes or contacts. [4]

The difference in oxygen levels between the exhaust and outside air within the sensor causes voltage to flow through the ceramic bulb. The greater the difference, the higher the voltage reading is. An EGO sensor will typically generate up to about 0.9 volts when the fuel mixture is rich and there is little unburned oxygen in the exhaust. When the mixture is lean, the sensor output voltage will drop down to about 0.2 volts or less. When the air/fuel mixture is balanced or at the equilibrium point of about 14.5 to 1, the sensor will read around 0.45 volts.

When the computer receives a rich signal (high voltage) from the EGO sensor, it leans the fuel mixture to reduce the sensor's feedback voltage. When its reading goes lean (low voltage), the computer reverses again making the fuel mixture goes rich. This constant flip-flopping back and forth of the fuel mixture occurs with different speeds depending on the fuel system.

The EGO sensor must be hot (about 700 degrees or higher) before it will start to generate a voltage signal, so many oxygen sensors have a small heating element inside to help them reach operating temperature more quickly. The heating element can also prevent the sensor from cooling off too much during prolonged idle, which would cause the system to revert to open loop. [5,6]

II. METHODOLOGY

The block diagram of Air/Fuel control system using exhaust gas oxygen sensor is shown in Fig. 1. In order to use the TWC (three-way catalytic converter) effectively, feedback from an EGO (exhaust gas oxygen) sensor in the vehicle exhaust system is utilized to regulate the A/F operating point.

The signal from EGO sensor is fed back through a comparator and digital PI controller to adjust an average A/F close to stoichiometry. Although the average A/F is controlled to perceived stoichiometry, individual cylinder may be operating consistently rich or lean of the desired value. The

development of a controller for tuning the A/F in each cylinder of a four cylinder engine is used to eliminate maldistribution. The greatly varying A/F at the EGO sensor could adversely affect the catalyst efficiency and life time.

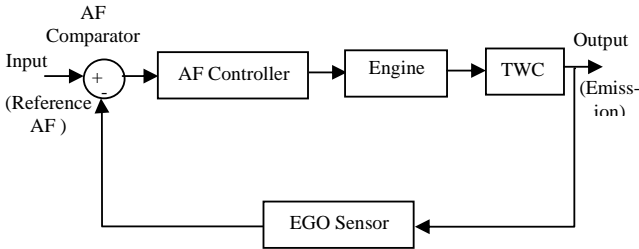

Fig. 1 Block diagram of air/fuel control system

A. Design Consideration

The air-fuel control system and the flowchart of air-fuel ratio for it will be discussed.

B. Air-Fuel Control System

In order to construct a simplified mathematical model of air/fuel control loop, there are three assumptions: (1) it is supposed that the mass flow rate of air is constant, (2) the exhaust gas mixing in the individual runners, as well as between the runners and the sensor, can be neglected and (3) the transport delays of the four exhaust runners are approximately equal.

The design of the AFR controller includes variable time delay, uncertain plant behavior and disturbances. The time delay in the system comprises two basic components: the time, it takes from the fuel injection calculation to exhaust gas exiting the cylinders and the time, it takes for the exhaust gases to reach the EGO sensor location. The time delay in the system is a key factor limiting the bandwidth of the FAR feedback loop. The plant uncertainties are the result of inaccuracies in the air charge estimation and changes in the UEGO sensor due to aging. When the carbon canister, which stores the fuel vapor generated in the fuel tank, is purged, the fuel content in the purge own into the intake manifold is also uncertain and creates disturbance to the FAR control loop.

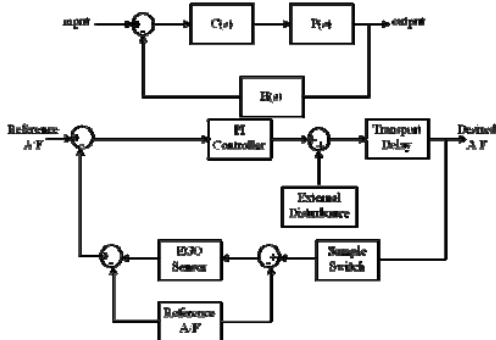

Fig. 2 Air/Fuel Control System with PI Controller

C. Flowchart

The flowchart of the process to control the air-fuel ratio is shown in Fig. 3. Firstly, the engine temperature is checked which it will be higher 700°C or not. Then, the procedure of checking is performed whether the EGO sensor output voltage is equal to reference voltage or not. If EGO sensor output is not equal to reference, the valve position is open or close to reach the equilibrium condition as soon as possible.

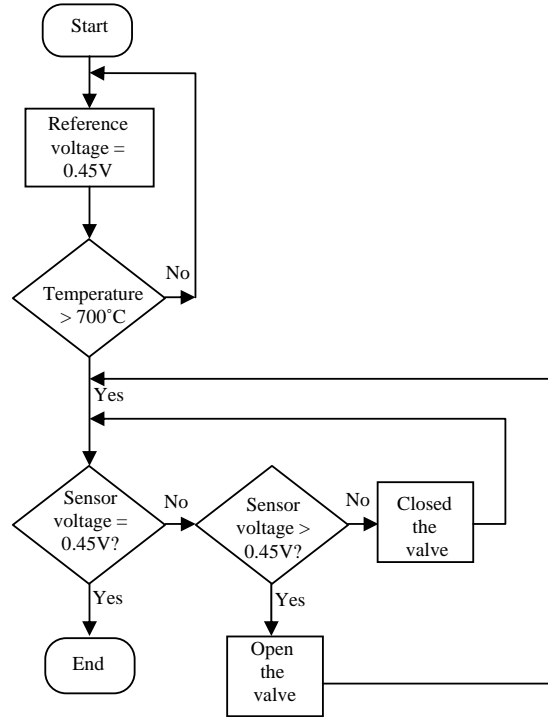

Fig. 3 Flowchart of the air-fuel control process

D. Software Implementation

The mathematical model of air/fuel control system is presented in Fig. 4. The results shown in this section are tested with variable parameters such as proportional gain (K_p), integral gain (K_i) and sampling period (T) changing the appropriate practical values.

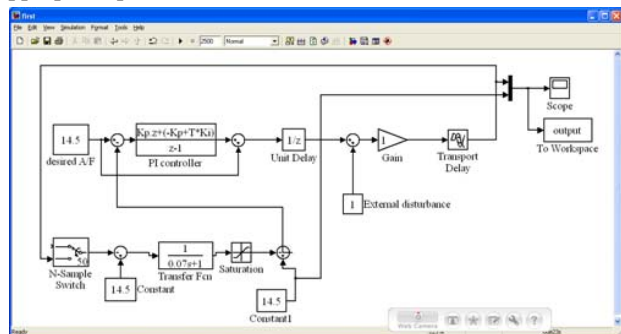

Fig. 4 Mathematical Model of Air/Fuel Control System in Matlab/Simulink

III. RESULTS

In distributorless CNG engine, it is essential to maintain AFR at stoichiometry as soon as possible, i.e. with the least amount of engine events. In order to achieve this requirement, in this case I, by changing the control parameters, K_p and K_i within allowable range, the transient response of the system is monitored.

According to simulation results from Fig. 5, it can be found that the system matches its reference value with the least amount of engine events 720 rad/sec at $K_p = 0.09$ and $K_i = 0.33$ while percent overshoot is 10.3% which is allowable.

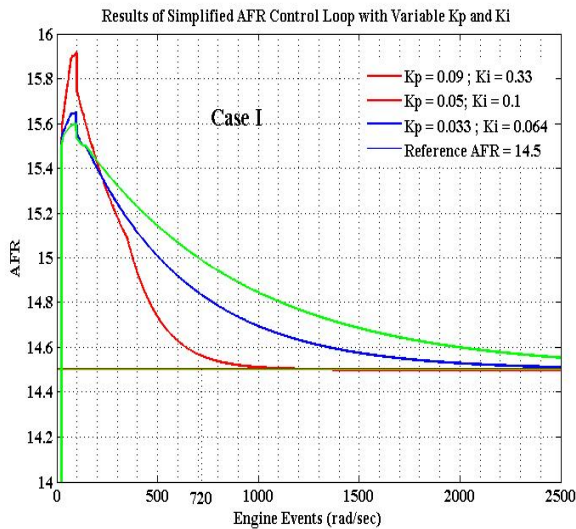

Fig. 5 Results of Air/Fuel Control Loop with Variable K_p and K_i

In considering the maintainability of AFR control system for distributorless CNG engine, the sampling period, T also plays an important role. The value of T is related with the engine speed, N and number of cylinders, n by the following equation:

$$T = \frac{120}{n \times N} \quad (1)$$

In case II, the number of cylinders is four and so the research is done by varying T depending on the engine speed, N . The value of sampling time T will be changed to get the stoichiometry (14.5:1 for CNG engine) within the minimum engine events. [7]

Although the settling times of these three results are not quite different, the result 1 is chosen because of its shortest settling time. All these results are shown in Fig. 6.

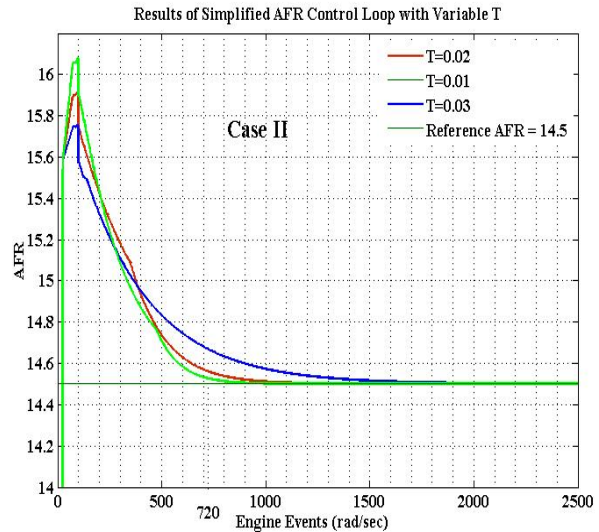

Fig. 6 Results of Air/Fuel Control Loop with Variable T

After obtaining the optimized values of K_p , K_i and T , the system is tested with external disturbance to determine its sensitivity. According to the simulation results from Fig.7, it can be obviously seen that the system can also maintain the required AFR at stoichiometry even with external disturbance value, 1, within the limited minimum engine events, 720 rad/sec. In other words, it also shows the better performance of the implemented control system.

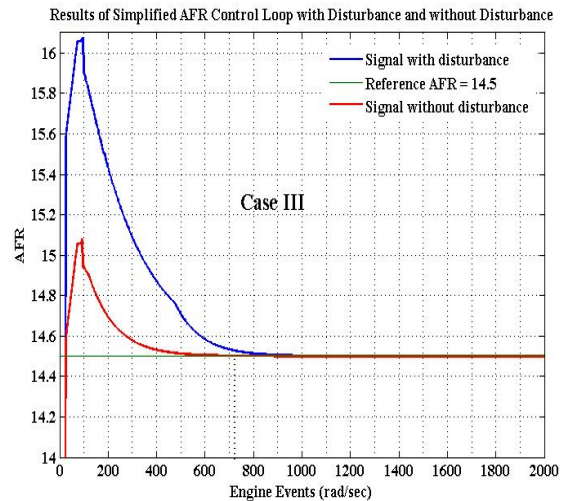

Fig. 7 Results of Air/Fuel Control Loop without Disturbance and with Disturbance

IV. CONCLUSION

As a conclusion, this research work has fulfilled its main objective to control the precise air/fuel ratio, in other words, to overcome the problem of air pollution (exhaust emission). The air/fuel control system is implemented with the help of simulation environment, MATLAB R2008b. This control

system can eliminate the air/fuel maldistribution in about 720 engine events, and maintain the air/fuel ratio as close as possible to stoichiometry (14.5:1) within the limited time range. It is expected to apply the implemented air-fuel control system for the distributorless CNG engine in the future.

ACKNOWLEDGMENT

The author gratefully acknowledges supervisor and co-supervisor, the contributions of teachers from the department of electronic engineering and information technology, YTU, the supporting companies, teachers from the mechanical department, YTU for their advices about the engine operation and project colleagues for their comments and supports on this document.

REFERENCES

- [1] Manzie C, Palaniswami M I, Ralph D, et al. Model predictive control of a fuel injection system with a radial basis function network observer [J]. *Journal of Dynamic Systems Measurement and Control*. 2002, 124,(4): 648-658.
- [2] Takeshi Takiyama, Eisuke Shiomi, Shigeyuki Morita. Air – fuel ratio control system using pulse width and amplitude modulation at transient state. *JSAE Review*. 2001, 22:537-544.
- [3] Andrew Mills. Controlling the sensitivity of optical oxygen sensors. *Sensors and Actuators B*. 1998, 51:60-68.
- [4] Mianzo, L., Peng, H., Haskara, I., 2001. Transient air-fuel ratio H8 preview control of a drive-by-wire internal combustion engine. In: *Proc. Amer. Control Conf.* pp. 2867-2871.
- [5] Muske, K. R., Jones, C. P. J., 2006. A model-based si engine air fuel ratio controller In: *Proc. Amer. Control Conf.* pp. 3284-3289.
- [6] Nakagawa, S., Katogi, K., Oosuga, M., 2002. A new air-fuel ratio feedback control for ulev/sulev standard. *SAE Paper (2002-01-0194)*.
- [7] Ei Ei Moe, Dr. Zaw Min Aung, Dr. Kyawt Khin, Digital Ignition System for Distributorless CNG Engine, ICBIR Conference 2010, Bangkok, Thailand..