

Current-Mode Resistorless SIMO Universal Filter and Four-Phase Quadrature Oscillator

Jie Jin

Abstract—In this paper, a new CMOS current-mode single input and multi-outputs (SIMO) universal filter and quadrature oscillator with a similar circuit are proposed. The circuits only consist of three Current differencing transconductance amplifiers (CDTA) and two grounded capacitors, which are resistorless, and they are suitable for monolithic integration. The universal filter uses minimum CDTAs and passive elements to realize SIMO type low-pass (LP), high-pass (HP), band-pass (BP) band-stop (BS) and all-pass (AP) filter functions simultaneously without any component matching conditions. The angular frequency (ω_0) and the quality factor (Q) of the proposed filter can be electronically controlled and tuned orthogonal. By some modifications of the filter, a new current-mode four-phase quadrature oscillator (QO) can be obtained easily. The condition of oscillation (CO) and frequency of oscillation (FO) of the QO can be controlled electronically and independently through the bias current of the CDTAs, and it is suitable for variable frequency oscillator. Moreover, all the passive and active sensitivities of the circuits are low. SPICE simulation results are included to confirm the theory.

Keywords—Universal Filter, Quadrature Oscillator, Current mode, Current differencing transconductance amplifiers.

I. INTRODUCTION

DURING the past few years, in active filters and oscillators design, the current-mode approach [1] has become more popular due to its advantages of providing larger dynamic range, wider bandwidth, lower power consumption and simpler filtering configurations over the voltage-mode counterparts, especially for the high-frequency operation. Many current-mode active elements have been reported, such as operational transconductance amplifier (OTA) [2], [3], current conveyor [4], [5], current operational amplifier [6], [7], current differencing buffered amplifier (CDBA) [8], [9] and current differencing transconductance amplifiers (CDTA).

After D. Birolek proposed the current differencing transconductance amplifier [10], [11], great interests have been devoted to analyze and develop this new block [12]. The CDTA is a synthesis of the well-know advantages of the CDBA [13] and OTA. It is a really current-mode element whose inputs and outputs are all current form. Several realizations of current-mode filters and oscillators using CDTA have been reported in the literature [11], [12], [14]-[18], [19]-[26].

The filters in [12], [16]-[18] are not SIMO type filters; they cannot provide universal filter functions simultaneously. The SIMO type filters are also reported in [11], [14], [15]. However, the work in [11] can only provide LP, BP and HP filter functions, and the band-stop (BS) and all-pass (AP) responses

cannot be realized from this configuration; although, the work in [14], [15] only use one or two CDTA, they cannot realize high-impedance outputs, they need component matching at the outputs. Moreover, four passive components are used in [15], and two of them are floating, which is not suitable for monolithic integration. The QOs reported in [19]-[26] cannot provide completely independently controlling of the CO and FO, and the works in [19], [20], [24] have floating passive components. Moreover, the works in [19]-[22], [24] cannot provide four-phase quadrature outputs.

This paper presents a new CMOS SIMO universal filter and QO based on CDTA. The two circuits are all resistorless, and only consist of three CDTAs and two grounded capacitors, respectively. The universal filter uses minimum CDTAs and passive elements to realize SIMO type low-pass (LP), high-pass (HP), band-pass (BP) band-stop (BS) and all-pass (AP) filter functions simultaneously without any component matching conditions. The angular frequency (ω_0) and the quality factor (Q) of the proposed filter can be electronically controlled and tuned orthogonal. By some modification of the filter, a new current-mode four-phase quadrature oscillator (QO) can be obtained easily. The condition of oscillation (CO) and frequency of oscillation (FO) of the QO can be controlled electronically and independently through the bias current of the CDTAs, and it is suitable for variable frequency oscillator. Moreover, all the passive and active sensitivities of the circuits are low.

II. CIRCUIT SYMBOL OF CDTA AND ITS REALIZATION CIRCUIT

Fig. 1 (a) denotes the symbol of CDTA, Fig. 1 (b) is the equivalent circuit of the CDTA. The terminal relation of the CDTA can be characterized by the following set of equations [18]:

$$\begin{aligned} v_p &= v_n = 0 \\ i_z &= i_p - i_n \\ i_x + &= g_m v_z = g_m Z_z i_z \\ i_x - &= -g_m v_z = -g_m Z_z i_z \end{aligned} \quad (1)$$

where p and n are input terminals, z and x are output terminals, g_m is the transconductance gain, and Z_z is an external impedance connected at the terminal z. From (1), the current i_z follows the difference of the currents through the terminals p and n ($i_p - i_n$), and flows from the terminal z into an impedance Z_z . The voltage drop at the terminal z is transferred to a current at the terminal x (i_x) by a transconductance gain (g_m), which is

generally electronically controllable by an external bias current I_b .

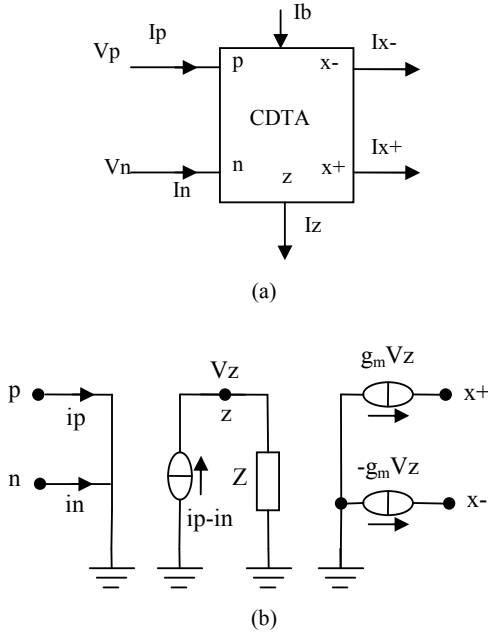

Fig. 1 CDTA (a) Symbol (b) Equivalent circuit

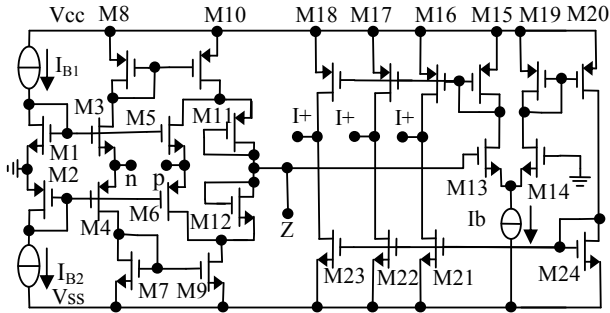

Fig. 2 CMOS-based CDTA in this work [19]

The possible CMOS realization of the CDTA used in this work is shown in Fig. 2 [19]. The circuit consists of a current differencing circuit M1-M12, and a transconductance amplifier M13-M24. The current differencing circuit part (M1-M12) realize the function of “ $I_z=I_p-I_n$ ”; and the transconductance amplifier (M13-M24) realize the function of “ $I_x=g_m*(I_p-I_n)=g_mV_z$ ”, and the transconductance gain (g_m) of the transconductance amplifier can be set by I_b .

The CDTA used in this work is shown in Fig. 2. Assuming transistors M13 and M14 are operated in the saturation region, the transconductance gain (g_m) can be expressed as:

$$g_m = \sqrt{\mu C_{ox} (W/L) |I_b|} \quad (2)$$

where μ is carrier mobility, C_{ox} is the gate oxide capacitance per unit area.

From (2), we can know that the transconductance gain can be electronically controlled by adjusting the bias current I_b .

III. PROPOSED CURRENT MODE FILTER AND QUADRATURE OSCILLATOR

A. The CDTA-Based Current-Mode SIMO Universal Filter

The proposed circuit is shown in Fig. 3. This circuit contains three CDTAs and two grounded capacitors. I_{in} denotes input signal, and I_{o1} , I_{o2} , I_{o3} , I_{o4} present the four outputs respectively.

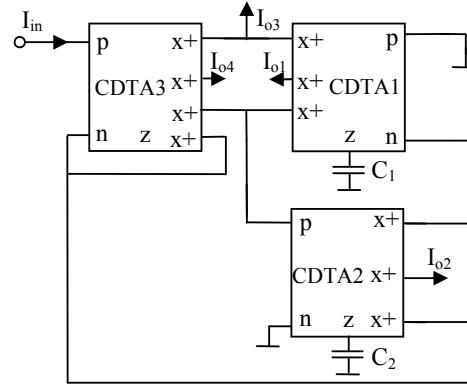

Fig. 3 The proposed current-mode SIMO universal filter

Using (1), analyzing Fig. 3 yields following current transfer functions as (3)-(7).

$$T_{LP}(s) = \frac{I_{o1}}{I_{in}} = -\frac{\frac{g_{m1}g_{m2}}{C_1C_2}}{s^2 + s\frac{g_{m2}}{C_2} + \frac{g_{m1}g_{m2}}{C_1C_2}} \quad (3)$$

$$T_{BP}(s) = \frac{I_{o2}}{I_{in}} = \frac{\frac{g_{m2}}{C_2}}{s^2 + s\frac{g_{m2}}{C_2} + \frac{g_{m1}g_{m2}}{C_1C_2}} \quad (4)$$

$$T_{HP}(s) = \frac{I_{o3}}{I_{in}} = \frac{s^2}{s^2 + s\frac{g_{m2}}{C_2} + \frac{g_{m1}g_{m2}}{C_1C_2}} \quad (5)$$

$$T_{BS}(s) = \frac{I_{o4}}{I_{in}} = \frac{s^2 + \frac{g_{m1}g_{m2}}{C_1C_2}}{s^2 + s\frac{g_{m2}}{C_2} + \frac{g_{m1}g_{m2}}{C_1C_2}} \quad (6)$$

$$T_{AP}(s) = \frac{I_{o4} - I_{o2}}{I_{in}} = \frac{s^2 - s\frac{g_{m2}}{C_2} + \frac{g_{m1}g_{m2}}{C_1C_2}}{s^2 + s\frac{g_{m2}}{C_2} + \frac{g_{m1}g_{m2}}{C_1C_2}} \quad (7)$$

It is clear from (3)-(7) that I_{o1} is the low-pass output, I_{o2} is the band-pass output, I_{o3} is the high-pass output, I_{o4} is the notch output and $(I_{o4} - I_{o2})$ is the all-pass output. From the above

calculations, the angular frequency and quality factor of this filter can get in (8)-(9).

$$\omega_0 = \sqrt{\frac{g_{m1}g_{m2}}{C_1C_2}} \quad (8)$$

$$Q = \sqrt{\frac{g_{m1}C_2}{g_{m2}C_1}} \quad (9)$$

From (8)-(9), it is clear that, the SIMO filter has orthogonal tuning capability for the characteristic parameters ω_0 and Q .

B. The CDTA-Based Quadrature Oscillator

By setting $I_m=0$, connecting the terminals p and z of the CDTA₃ to the terminals x and z of the CDTA₂ respectively, and disconnecting the terminal x of the CDTA₃ to the terminal x of the CDTA₁ in Fig. 3, the proposed CDTA-based current-mode four-phase quadrature oscillator can be obtained as shown in Fig. 4.

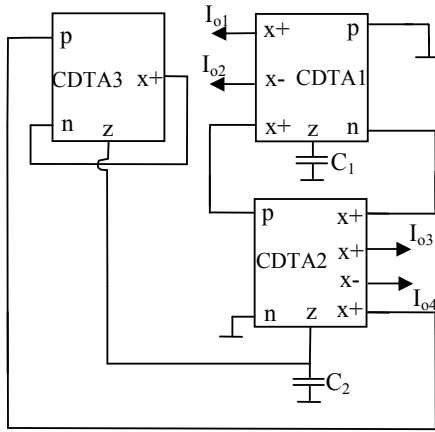

Fig. 4 The proposed current-mode quadrature oscillator

A routine circuit analysis of the configuration using (1), the characteristic equation of the oscillator is:

$$s^2C_1C + s(g_{m3} - g_{m2})C_1 + g_{m1}g_{m2} = 0 \quad (10)$$

From (10), the condition of oscillation (CO) and frequency of oscillation (FO) can be expressed as:

$$g_{m3} \leq g_{m2} \quad (11)$$

$$\omega_{osc} = \sqrt{\frac{g_{m1}g_{m2}}{C_1C_2}} \quad (12)$$

From Fig. 4, the current transfer function between I_{o1} and I_{o2} is:

$$\frac{I_{o1}(s)}{I_{o2}(s)} = -\frac{g_{m1}}{sC_2} = \frac{I_{o1}(j\omega)}{I_{o2}(j\omega)} = \frac{g_{m1}}{\omega C_2} e^{j90^\circ} \quad (13)$$

Therefore, the phase difference between I_{o1} and I_{o2} is 90° , and the two currents are quadrature. From (11) and (12), it can be seen that the CO can be adjusted independently from the FO by g_{m3} , while the FO can be adjusted independently by g_{m1} , and it is suitable for variable frequency oscillator. The CO and FO are controlled independently and electronically, which is a big advantage of the proposed QO.

IV. NON-IDEAL ANALYSIS

Taking the non-idealities of the CDTA into account, the port relations of the non-ideal CDTA can be rewritten as:

$$\begin{aligned} v_p &= v_n = 0 \\ i_z &= \alpha_p i_p - \alpha_n i_n \\ i_{x+} &= \beta g_m v_z \end{aligned} \quad (14)$$

where $\alpha_p = 1 - \epsilon_p$ denotes the current tracking error from terminal p to z, and $\alpha_n = 1 - \epsilon_n$ denotes the current tracking error from terminal n to z, and β is transconductance inaccuracy factor from the z to x terminals of the CDTA, respectively. α_{pi} , α_{ni} and β_i are the parameters α_p , α_n and β of the i-th CDTA, respectively.

Using (14), the denominator polynomials of the current transfer functions of the SIMO universal filter can be described by:

$$D(s) = s^2 + s \frac{\alpha_{n3}\alpha_{p2}\beta_2g_{m2}}{C_2} + \frac{\alpha_{n1}\alpha_{p2}\beta_1\beta_2g_{m1}g_{m2}}{C_1C_2} \quad (15)$$

In this case, the modified parameters ω_0 and Q are given by:

$$\omega_0' = \sqrt{\frac{\alpha_{n1}\alpha_{p2}\beta_1\beta_2g_{m1}g_{m2}}{C_1C_2}} \quad (16)$$

$$Q' = \frac{1}{\alpha_{n3}} \sqrt{\frac{\alpha_{n1}\beta_1g_{m1}C_2}{\alpha_{p2}\beta_2g_{m2}C_1}} \quad (17)$$

The active and passive sensitivities of the SIMO universal filter are:

$$\begin{aligned} S_{\alpha_{n1}, \alpha_{p2}, \beta_1, \beta_2, g_{m1}, g_{m2}}^{\omega_0'} &= \frac{1}{2}, S_{C_1, C_2}^{\omega_0'} = -\frac{1}{2} \\ S_{\alpha_{n1}, \beta_1, g_{m1}, C_2}^{Q'} &= \frac{1}{2}, S_{\alpha_{p2}, \beta_2, g_{m2}, C_1}^{Q'} = -\frac{1}{2} \\ S_{\alpha_{n3}}^{Q'} &= -1 \end{aligned} \quad (18)$$

And the characteristic equation of the QO can be rewritten as:

$$\begin{aligned} s^2C_1C + s(\alpha_{n3}\beta_3g_{m3} - \alpha_{p3}\beta_2g_{m2})C_1 \\ + \alpha_{n1}\alpha_{p2}\beta_1\beta_2g_{m1}g_{m2} = 0 \end{aligned} \quad (19)$$

Considering the non-ideal effects, the CO and FO of the QO is revised as:

$$\alpha_{n3}\beta_3g_{m3} \leq \alpha_{p3}\beta_2g_{m2} \quad (20)$$

$$\omega_{osc} = \sqrt{\frac{\alpha_{n1}\alpha_{p2}\beta_1\beta_2g_{m1}g_{m2}}{C_1C_2}} \quad (21)$$

The active and passive sensitivities for the QO can be written as:

$$S_{\alpha_{n1}, \alpha_{p2}, \beta_1, \beta_2, g_{m1}, g_{m2}}^{\omega_{osc}} = \frac{1}{2}$$

$$S_{C_1, C_2}^{\omega_{osc}} = -\frac{1}{2} \quad (22)$$

From the above calculations, it can be seen that all the active and passive sensitivities of the SIMO universal filter and the QO are constant and less than or equal to unity.

V. SIMULATION RESULTS

The characteristics of the proposed circuit of Figs. 3 and 4 have been verified using PSPICE. The CMOS CDTA used in the simulations is given in Fig. 2. [19].

The simulation results of the SIMO universal filter are presented in Figs. 5–8.

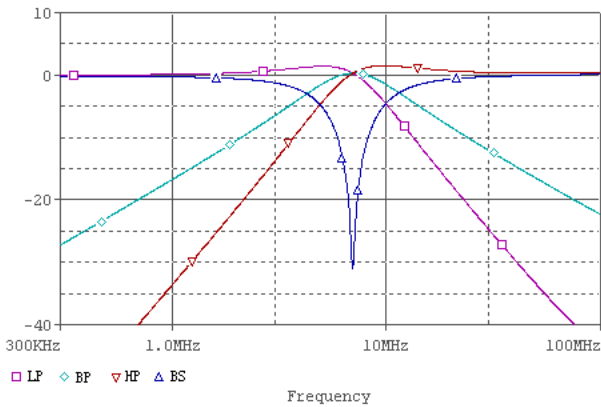

Fig. 5 Frequency responses for LP, BP, HP and BS characteristic

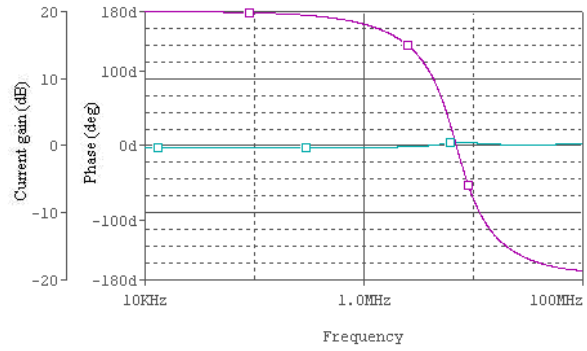

Fig. 6 Frequency responses for the AP characteristic

Fig. 5 presents the LP, BP, HP and BS simulation results of the SIMO universal current-mode filter; Fig. 6 shows the gain and phase responses of the AP simulation results of the filter with $C_1=10pF$, $C_2=10pF$, $I_{B1}=I_{B2}=100\mu A$, $I_b=350\mu A$ for all the three CDTAs. From (2), (8) and (9), we can get $f_o=\omega_o/2\pi\approx 8.42MHz$, while $Q=1$.

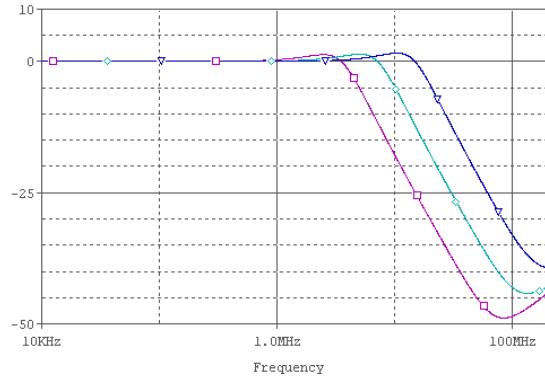

Fig. 7 Frequency responses for the LP with f_0 -tuning

Fig. 7 shows the simulated low-pass responses with f_0 ($f_0=\omega_o/2\pi$) tuning (i.e. $f_0=4.8MHz$, $8.4MHz$, $16.8MHz$), while keeping $Q=1$. In this case, the capacitances are $C_1=20pF$, $C_2=20pF$ for $f_0=4.8MHz$; $C_1=10pF$, $C_2=10pF$ for $f_0=8.4MHz$; $C_1=5pF$, $C_2=5pF$ for $f_0=16.8MHz$.

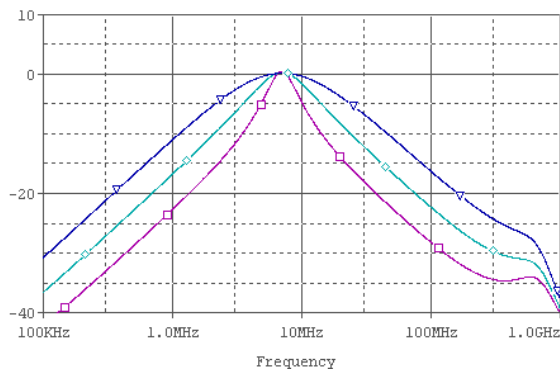

Fig. 8 Frequency responses for the BP with Q -tuning

Fig. 8 shows the simulated band-pass responses with Q-tuning (i.e. $Q=0.5, 1, 2$), while keeping $f_0 = 8.4$ MHz. In this case, the capacitances are $C_1=20$ pF, $C_2=5$ pF for $Q=0.5$; $C_1=10$ pF, $C_2=10$ pF for $Q=1$; $C_1=5$ pF, $C_2=20$ pF for $Q=2$.

The simulation results of the four-phase QO are presented in Figs. 9–12. Fig. 9 shows the output waveforms of I_{o1} and I_{o3} ; Fig. 10 shows the output waveforms of I_{o2} and I_{o4} ; Fig. 11 shows all the output waveforms of I_{o1} , I_{o2} , I_{o3} and I_{o4} ; the frequency spectrums of the QO are shown in Fig. 12. The simulated frequency of the oscillation is found to be 2.1 MHz, the amplitude of the output currents is about 200 μ A., and the total harmonic distortion (THD) of the output waveforms I_{o1} , I_{o2} , I_{o3} and I_{o4} are 0.9% to 1.2%.

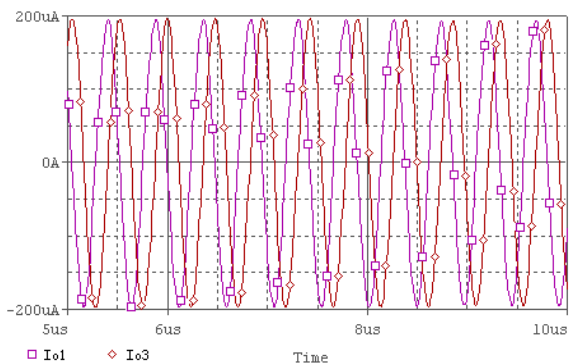

Fig. 9 The Simulated I_{o1} and I_{o3} of the oscillator

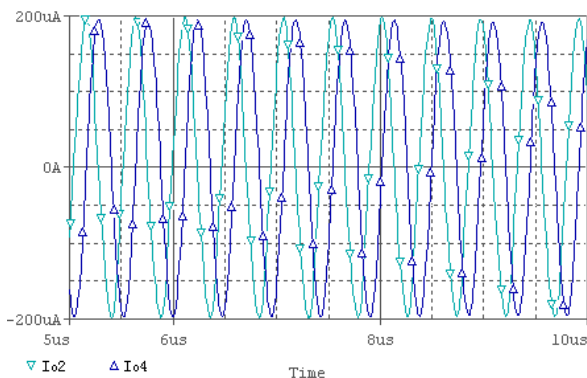

Fig. 10 The Simulated I_{o2} and I_{o4} of the oscillator

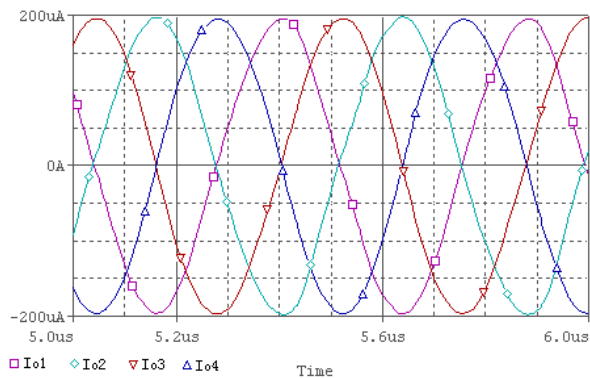

Fig. 11 The Simulated I_{o1} , I_{o2} , I_{o3} and I_{o4} of the oscillator

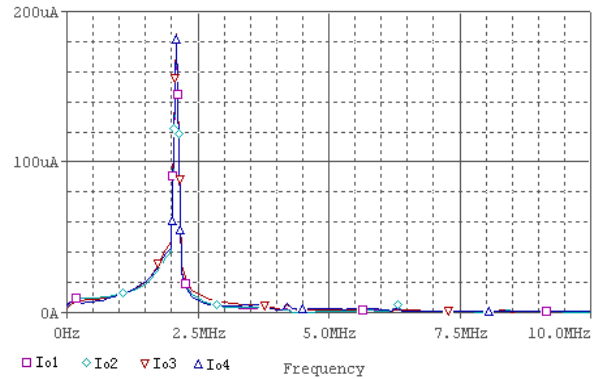

Fig. 12 The simulated frequency spectrums of the oscillator

VI. CONCLUSIONS

This paper presents new CDTA based SIMO universal filter and QO in a similar circuit. The two circuits have following advantages: (a) the circuits only consist of active blocks and grounded capacitors, and it is easy for monolithic integration; (b) The SIMO universal filter uses minimum CDTAs and passive elements to realize LP, HP, BP, BS and AP filter functions simultaneously without any component matching conditions; (c) the angular frequency (ω_o) and the quality factor (Q) of the proposed filter can be electronically controlled and tuned orthogonal; (d) by some modifications of the filter, a new current-mode four-phase quadrature oscillator (QO) can be obtained easily, and the CO and FO of the QO can be controlled electronically and independently through the bias current of the CDTAs, and it is suitable for variable frequency oscillator. (e) all the passive and active sensitivities of the circuits are low.

REFERENCES

- [1] Toumazou C, Lidjey F J, Haigh D. Analog IC design: The current mode approach. UK: Peter Peregrinus press, 1990, pp. 195-207
- [2] L. Tien-Yu, K. Cheng-Sheng, H. Chung-Chih, A Gm-C continuous-time analog filter for IEEE 802.11 a/b/g/n wireless LANs. *Analog Integrated Circuits and Signal Processing*, vol. 58, 2009, pp. 197-204.
- [3] F. Rezaei, S. J. Azhari, Ultra low voltage, high performance operational transconductance amplifier and its application in a tunable Gm-C filter, *Microelectronics Journal*, vol. 42, 2011, pp. 827-836.
- [4] W. Chunhua, K. A. Umit, L. Yang, Minimum Configuration Insensitive Multifunctional Current-Mode Biquad Using Current Conveyors and All-Grounded Passive Components, *Radioengineering*, vol. 19, 2010, pp. 178-184.
- [5] W. Chunhua, Z. Yan, Z. Qiujing, A New Current Mode SIMO-Type Universal Biquad Employing Multi-Output Current Conveyors (MOCCIs), *Radioengineering*, vol. 18, 2009, pp. 83-88.
- [6] K. Novacek, P. Betak, Low-Voltage Current Operational Amplifier, The 30th International Spring Seminar on Electronics Technology, Cluj-Napoca, Romania, 2007, pp.326-329.
- [7] K. Novacek, T. Brich, A. Khateb, Current Operational Amplifier, *The 29th International Spring Seminar on Electronics Technology*, 2006, pp.340-344.
- [8] S. Mehmet, Design of CDBA-based active poly phase filter for low-IF receiver applications, *Turkish Journal of Electrical Engineering and Computer Sciences*, vol. 19, 2011, pp. 565-574.
- [9] J. Bajer, J. Vavra, D. Bielek, A new building block for analog signal processing: current follower/inverter buffered transconductance amplifier, Research in Microelectronics and Electronics, 2009. PRIME 2009. Ph.D, 2009, pp.136-139.
- [10] D. Bielek, CDTA - Building block for current-mode analog signal processing, *Proc. ECCTD'03*, 2003, pp. 397- 400.

- [11] D. Biolek, V. Biolkova, CDTA-C current-mode universal 2nd-order filter, *Proceedings of the 5th WSEAS International Conference on Applied Informatics and Communications*, 2005, pp. 411-414.
- [12] K. Firat, K. H. Hakan, A new improved CMOS realization of CDTA and its filter applications, *Turkish Journal of Electrical Engineering and Computer Sciences*, vol. 19, 2011, pp. 631-642.
- [13] C. Acar, S. Ozoguz, A new versatile building block: current differencing buffered amplifier suitable for analog signal processing filters, *Microelectronics Journal*, vol. 30, 1999, pp. 157-160.
- [14] A. Ü. Keskin, D. Biolek, E. Hancioglu, V. Biolková, Current mode KHN filter employing current differencing transconductance amplifiers, *AEU-International Journal of Electronics and Communication*, vol. 60, 2006, pp. 443-446.
- [15] D. Prasad, D.R. Bhaskar, A.K. Singh, Universal current-mode biquad filter using dual output current differencing transconductance amplifier, *AEU-International Journal of Electronics and Communication*, vol.63, 2009, pp. 497-501.
- [16] A. Bekri, F. Anday, Nth-order low-pass filter employing current differencing transconductance amplifiers, *Proceeding of the 2005 European Conference on Circuit Theory and Design*, Cork, Ireland , 2005, pp.193-196.
- [17] D. Biolek, V. Biolkova, Universal biquads using CDTA elements for cascade filter design, *Proceeding of CICC 2003*, Athens Greece, 2003, pp. 8-12.
- [18] N. A. Shah, M. Quadri, S. Z. Iqbal, CDTA based universal transadmittance filter, *Analog Integr Circ Sig Process*, vol. 52, 2007, pp. 65-69.
- [19] A.U. Keskin, D. Biolek, Current mode quadrature oscillator using current differencing transconductance amplifiers (CDTA), *IET-Circuits, Devices and Systems*, vol. 153, 2006, pp. 214-218.
- [20] A. Uygur, H. Kuntman, CDTA-Based Quadrature Oscillator Design, *14th European Signal Processing Conference (EUSIPCO 2006)*, Florence, Italy, 2006. pp. 4-8.
- [21] A. Lahiri, New current-mode quadrature oscillators using CDTA, *IEICE Electronics Express*, vol. 6, 2009, pp.135-140.
- [22] A. Lahiri. Novel voltage/current-mode quadrature oscillator using current differencing transconductance amplifier, *Analog Integr Circ Sig Process* , vol. 61, 2009, pp. 199–203.
- [23] W. Jaikla, A. Lahiri, Resistor-less current-mode four-phase quadrature oscillator using CCCDTAs and grounded capacitors, *AEU-International Journal of Electronics and Communication*, vol. 66, 2012, pp. 214-218.
- [24] W. Tangsrirat, T. Pukkalanun, W. Surakamponorn, Resistorless realization of current-mode first-order allpass filter using current differencing transconductance amplifiers, *Microelectronics Journal*, vol. 41, 2010, pp.178–183.
- [25] D. Prasad, D. R. Bhaskar, A. K. Singh, Electronically Controllable Grounded Capacitor Current-Mode Quadrature Oscillator Using Single MO-CCCDTA, *Radioengineering*, vol. 20, 2011, pp. 354-359.
- [26] Y. Li, Electronically Tunable Current-Mode Quadrature Oscillator Using Single MCDTA, *Radioengineering*, vol.19, 2010, pp. 667-671.