

Component Criticality Importance Measures in Thermal Power Plants Design

Smajo Bisanovic, Mensur Hajro, Mersiha Samardzic

Abstract—This paper presents quantitative component criticality importance indices applicable for identifying and ranking critical components in the phase of thermal power plants design. Identifying critical components for power plant reliability provides one important input to decision-making and guidance throughout the development project. The study of components criticality importance indices to several characteristic structural schemes of conventional thermal power plant is presented and discussed.

Keywords—Component criticality importance measures, discrete event, reliability, thermal power plant.

I. INTRODUCTION

NOWADAYS stage of thermal power plant design and maintenance is characterized by a major complexity of equipment and technological schemes that requires an increase attention in their reliability. Therefore, power plant design must be able to quantify reliable and cost-effective choice of components with respect to the impact they have on plant reliability. The design could be optimized by risk, ranking the importance of components. When risk significant components are selected this way, the risk frequency can be improved by decreasing the unavailability of the selected components, modification/replacement with higher reliability components, improving the defense in root of failure occurrence component or decreasing the contribution frequencies of initial event [1].

Component importance measures are commonly used in risk assessments, particularly within probabilistic risk assessments of nuclear power plants [2], [3]. In power industry component importance measures are applied in different configurations of electrical networks design [4]–[6]. In these applications the component importance measures are called risk importance measures and are used to identify components that should be improved in order to reduce the risk and identify components for risk-based in service inspection and testing.

Component importance measures are applied in different phase of the plant's life cycle. In the design phase, the importance measure may be used to identify weak points and components that should be improved to increase the plant reliability. The reliability of a component may be improved by using a higher quality component, introducing redundant components, reducing the operational and environmental loads on the component or by improving the maintainability of the

component. The optimal improvements are complex problem and out of this scope. In the exploitation phase, the component importance measures may be used to allocate inspection and maintenance resources of the most important components.

Research and achievement of power plant optimal reliability presents complex problem that requires very carefully and coordinated work in the domain of achieving quality and reliability in electric power system. Important role in solving this problem should be played by methods of the forecast, optimization and normalizing reliability indices in dependence on basic technical and economical parameters, as well as development of methods for achieving reliability in the exploitation.

The importance measures quantify the criticality of particular component within a system design. They have been widely used as tools for identifying components that more significantly influence on the system behavior with respect to reliability, risk and safety. They can also provide valuable information for the maintenance and operation system. In this paper importance measures are used in case when components in thermal power plant exhibit a binary functioning behavior. This implies plant and plant components are either fully functioning or fully failed. For the binary case, components can be ranked with respect to the impact they have on power plant reliability based on a given importance measures. The multi-state reliability analysis can be used in the phase of preparation and design of power plant schemes, but with special attention. Namely, main power plant components (steam boiler, pumps, turbine), because of their characteristics in structural scheme, lose its total capabilities caused by damages. For example, damages in steam boiler pipe system reduce boiler capacity and power output of turbine and generator, but lead to new damages of pipe system and to a bigger loss of steam, with final outage. It is very important to recognize which parts of main power plant components can be modeled as multi-state components and can operate at various levels of performance, opposite to the binary perspective. These types of components may provide service or functioning at degraded component performance levels. In recent years, multi-state system reliability theory and analysis have received considerable attention [7].

The paper is organized as follows: Section II provides the overview of component criticality importance measures used in recent literature and applied for thermal power plant design. Section III applies and compares importance measures for different options of the structural scheme of conventional thermal power plant, and Section IV presents conclusions.

S. Bisanovic, M. Hajro, and M. Samardzic are with the Faculty of Electrical Engineering, University of Sarajevo, Zmaja od Bosne bb, Kampus Univerziteta, 71000 Sarajevo, Bosnia and Herzegovina (phone +387 33 250 700; fax: +387 33 250 725; e-mail: smajo.bisanovic@eff.unsa.ba, mensur.hajro@eff.unsa.ba, msamardzic1@eff.unsa.ba).

II. COMPONENT IMPORTANCE MEASURES FOR THERMAL POWER PLANT DESIGN

Finding the critical components is an important issue for reliability analysis and the optimization design of thermal power plant. The aim is to obtain information concerning component's contribution to the plant reliability. Reliability importance indices are valuable in establishing direction and prioritization of actions related to reliability improvement in power plant design or in suggesting the most efficient way to operate and maintain plant status. In general, component importance measures in plant use a numerical rank (relative importance), based on certain characteristic of interest, such as the component's contribution to power plant (failure) event occurrence. The most frequently used risk importance metrics (measures) are given in [1], [4], [8]–[12]. The following assumptions are made: (i) independent failure probabilities and repair times for components is a common simplification in reliability modeling, (ii) component states and associated probabilities are known, (iii) exponential distribution for repair time and time to failure, (iv) two-state model (in the power plant components are directly connected to each other) [4].

Birnbaum importance is one of the most widely used importance measures in risk theory. Analytically, Birnbaum measure of importance of component i at time t , is defined by:

$$I_i^B(t) = \frac{\partial R_s(t)}{\partial R_i(t)} = R_s(t; R_i(t) = 1) - R_s(t; R_i(t) = 0) \quad (1)$$

where $I_i^B(t)$ is the Birnbaum importance of component i , $R_s(t)$ the system (the power plant in our case) reliability at time t , $R_i(t)$ the reliability of component i at time t , $R_s(t; R_i(t) = 0)$ the power plant reliability at time t given component i is failed and $R_s(t; R_i(t) = 1)$ is the power plant reliability at time t given component i is perfectly working.

The Birnbaum importance is basically a sensitivity analysis in plant reliability due to component i . If $I_i^B(t)$ is large, a rather small change in the reliability of component i will have large consequences on the plant reliability at time t . The Birnbaum importance ranking represents the maximum loss in plant reliability when component i operates from the condition of perfect functioning ($R_i(t) = 1$) to the condition of certain failure ($R_i(t) = 0$). In (1) Birnbaum's importance measure of component i only depends on the structure of the plant and the reliabilities of the other components. $I_i^B(t)$ is independent of the reliability $R_i(t)$ of component i and this is the weakness of Birnbaum's importance measure. The fact that component i is critical for the system (plant), express nothing about the state of component i . The definition concerns other components of the plant only. If component i is critical for the plant, than component i must either be a cut set of order 1, or be a member of a cut set where all the other components in the same cut set have failed.

Another popular metric measure, is *criticality importance* measure that includes the unreliability of component, $F_i(t)$, whereas the Birnbaum importance measure does not.

Analytically, criticality importance is defined as:

$$I_i^{CR}(t) = I_i^B(t) \frac{F_i(t)}{F_s(t)} = \left[R_s(t; R_i(t) = 1) - R_s(t; R_i(t) = 0) \right] \frac{1 - R_i(t)}{1 - R_s(t)} \quad (2)$$

where $F_i(t)$ is the unreliability of component i at time t and $F_s(t)$ the system (the power plant) unreliability at time t .

Based on this definition, measure of criticality importance $I_i^{CR}(t)$ of component i at time t presents the probability that component i is critical for the power plant and is failed at time t , when the power plant is failed at time t . As motivation for introducing criticality importance measure, we note that component i is critical for the plant if the other components in the plant are in such states that the plant is functioning if and only if component i is functioning. To say that component i is critical, a statement about the other components in the plant is needed, and not statement about component i . Criticality importance measure is particularly suitable for prioritizing maintenance activities.

The *reliability achievement worth* (RAW) importance measure of component i is the ratio of the actual power plant reliability obtained when component i is always in perfect functioning ($R_i(t) = 1$) to the actual value of the power plant reliability. The RAW measure determines the maximum percentage increase in the power plant reliability generated by particular component:

$$I_i^{RAW}(t) = \frac{R_s(t; R_i(t) = 1)}{R_s(t)} \quad (3)$$

The *reliability reduction worth* (RRW) importance measure of component i is the ratio of the actual power plant reliability to the value of the plant reliability when component i is always in perfect unreliable ($R_i(t) = 0$). The RRW measure determines the index measuring the potential damage caused to the power plant by a particular component:

$$I_i^{RRW}(t) = \frac{R_s(t)}{R_s(t; R_i(t) = 0)} \quad (4)$$

Reliability achievement worth and reliability reduction worth measures are mainly used as a risk importance measures in probabilistic safety assessments of nuclear power plants.

Fussell-Vesely's importance measure $I_i^{FV}(t)$ is probability that at least one minimal cut set that contains component i is failed at time t , given that the power plant is failed at time t . According to this measure, the importance of a component i in the power plant depends on the number and the order of the cut-sets where appears. Analytically, Fussell-Vesely's metric is defined as:

$$I_i^{FV}(t) = \frac{\Pr(D_i(t))}{\Pr(C(t))} \approx \frac{\sum_{j=1}^m \Pi_j^i(t)}{1 - R_s(t)} \quad (5)$$

where $D_i(t)$ states that at least one of the minimal cut set containing component i has failed at time t , $C(t)$ states that the power plant is failed at time t , $\Pi_j^i(t)$ denotes the probability that the minimal cut set j , contains component i , is failed at time t .

Fussell-Vesely's measure takes into consideration the fact that component may contribute to power plant failure without being critical. The component contributes to plant failure when a minimal cut set, containing the component, is failed.

III. CASE STUDY

Several options of conventional thermal power plant of 600 MW including main pipes of the first and second loops (I_L , II_L), main circulation pumps and supply (feed) pumps (MCP, SP), steam boilers (SB) and turbines (T) as in Fig. 1, on which reliability block diagrams for total failure assessment are presented. Each component has enough capacity to satisfy the needs of its own generator at their nominal power output.

Selected design configurations (options) of conventional thermal power plant consider those components, which greatly depend on basic thermodynamic parameters [13], [14]. So, for example, steam boiler is component of synthesized heating surface, air heater, convectional and air economizer, screen and convection steam heaters, etc. Illustrated data applied in the calculation of component criticality importance measures for the thermal power plant design, are presented in Table I.

TABLE I
COMPONENT SPECIFICATION AND RELIABILITY DATA APPLIED IN THE
CALCULATIONS

option	Component reliability					
	I_L	MCP	SB	II_L	SP	T
#1	0.998	0.9945	0.997	0.998	0.9962	0.996
#2	0.997	0.991	0.995	0.997	0.9962	0.996
#3	0.997	0.991	0.995	0.9975	0.9962	0.992

Reliability importance measures were computed for each component and for each analyzed option. The components were ranked according to their importance based on their respective metric values as given in Tables II–IV.

Design configuration are different among themselves in a manner of reliability increase – by complicating structural scheme with great number of components with less capacity (higher quality component). Tables II–IV show the metric values and ranking of different components in the analyzed design configurations (options) in case of thermal power plant total failure.

For configuration (option) #1 the highest ranked component is steam turbine (T), the second ranked component is supply pump (SP), and the least important components are the first and the second loop (I_L , II_L), as shows Table II. This is conceptual identification regarding the component ranking,

although each importance metric has respective rank. From all analyzed different metrics, Criticality Importance measure and Fussell-Vesely's measure have close metric values and equal rank for each component in design option #1. In this option minimal cut sets fourth order are dominating because of topological scheme and component capacity that is enough to satisfy needs of owner generator at their nominal output.

For configuration #2 the highest ranked component is main circulation pump (MCP), the second ranked component is steam boiler (SB), and the least important components are the first and the second loop (I_L , II_L), as shows Table III. In this option all metrics have equal component rankings, except Reliability Reduction Worth importance measure that has rank equal 1 for all components and not provide information regarding the most important component. From all analyzed different metrics, Criticality Importance measure and Fussell-Vesely's measure have close metric values and equal rank for each component in study configuration #2. In this option minimal cut sets second order existing because of topological scheme and component capacity that is enough to satisfy needs of owner generator at their nominal output.

For configuration (option) #3 the highest ranked component is steam turbine (T), the second ranked component is main circulation pump (MCP), and the least important component is the second loop (II_L), as shows Table IV. In this option all metrics have equal component rankings, except Reliability Reduction Worth importance measure that has rank equal 2 for all components except steam turbine with boundless Reliability Reduction Worth value (Inf) and rank equal 1. From all analyzed different metrics, Criticality Importance measure and Fussell-Vesely's measure have close metric values and equal rank for each component in configuration #3. In this option minimal cut sets second order existing, plus one minimal cut set first order that relates to turbine outage.

TABLE II
COMPONENT RANKINGS AND METRIC VALUES FOR OPTION #1

comp.	mark	Birnbbaum		Criticality		Fussell-Vesely		RAW		RRW	
		rank	value	rank	value	rank	value	rank	value	rank	value
IL	1,5,11,15	3	0.000097	5	0.003079	5	0.003156	4	1.000000	2	1.000097
MCP	2,6,12,16	3	0.000097	3	0.008496	3	0.008680	3	1.000001	2	1.000097
SB	3,7,13,17	3	0.000097	4	0.004622	4	0.004734	4	1.000000	2	1.000097
II _L	4,8,14,18	3	0.000097	5	0.003079	5	0.003156	4	1.000000	2	1.000097
SP	9,19	2	0.007906	2	0.476692	2	0.479752	2	1.000030	1	1.007938
T	10,20	1	0.007907	1	0.501882	1	0.505002	1	1.000032	1	1.007938
minimal cut sets:	{1,5,11,15}, {1,5,11,16}, {1,5,11,17}, {1,5,11,18}, {1,5,12,15}, {1,5,12,16}, {1,5,12,17}, {1,5,12,18}, {1,5,13,15}, {1,5,13,16}, {1,5,13,17}, {1,5,13,18}, {1,5,14,15}, {1,5,14,16}, {1,5,14,17}, {1,5,14,18}, {1,5,19}, {1,5,20}, {1,6,11,15}, {1,6,11,16}, {1,6,11,17}, {1,6,11,18}, {1,6,12,15}, {1,6,12,16}, {1,6,12,17}, {1,6,12,18}, {1,6,13,15}, {1,6,13,16}, {1,6,13,17}, {1,6,13,18}, {1,6,14,15}, {1,6,14,16}, {1,6,14,17}, {1,6,14,18}, {1,6,19}, {1,6,20}, {1,7,11,15}, {1,7,11,16}, {1,7,11,17}, {1,7,11,18}, {1,7,12,15}, {1,7,12,16}, {1,7,12,17}, {1,7,12,18}, {1,7,13,15}, {1,7,13,16}, {1,7,13,17}, {1,7,13,18}, {1,7,14,15}, {1,7,14,16}, {1,7,14,17}, {1,7,14,18}, {1,7,19}, {1,7,20}, {1,8,11,15}, {1,8,11,16}, {1,8,11,17}, {1,8,11,18}, {1,8,12,15}, {1,8,12,16}, {1,8,12,17}, {1,8,12,18}, {1,8,13,15}, {1,8,13,16}, {1,8,13,17}, {1,8,13,18}, {1,8,14,15}, {1,8,14,16}, {1,8,14,17}, {1,8,14,18}, {1,8,19}, {1,8,20}, {2,5,11,15}, {2,5,11,16}, {2,5,11,17}, {2,5,11,18}, {2,5,12,15}, {2,5,12,16}, {2,5,12,17}, {2,5,12,18}, {2,5,13,15}, {2,5,13,16}, {2,5,13,17}, {2,5,13,18}, {2,5,14,15}, {2,5,14,16}, {2,5,14,17}, {2,5,14,18}, {2,5,19}, {2,5,20}, {2,6,11,15}, {2,6,11,16}, {2,6,11,17}, {2,6,11,18}, {2,6,12,15}, {2,6,12,16}, {2,6,12,17}, {2,6,12,18}, {2,6,13,15}, {2,6,13,16}, {2,6,13,17}, {2,6,13,18}, {2,6,14,15}, {2,6,14,16}, {2,6,14,17}, {2,6,14,18}, {2,6,19}, {2,6,20}, {2,7,11,15}, {2,7,11,16}, {2,7,11,17}, {2,7,11,18}, {2,7,12,15}, {2,7,12,16}, {2,7,12,17}, {2,7,12,18}, {2,7,13,15}, {2,7,13,16}, {2,7,13,17}, {2,7,13,18}, {2,7,14,15}, {2,7,14,16}, {2,7,14,17}, {2,7,14,18}, {2,7,19}, {2,7,20}, {2,8,11,15}, {2,8,11,16}, {2,8,11,17}, {2,8,11,18}, {2,8,12,15}, {2,8,12,16}, {2,8,12,17}, {2,8,12,18}, {2,8,13,15}, {2,8,13,16}, {2,8,13,17}, {2,8,13,18}, {2,8,14,15}, {2,8,14,16}, {2,8,14,17}, {2,8,14,18}, {2,8,19}, {2,8,20}, {3,5,11,15}, {3,5,11,16}, {3,5,11,17}, {3,5,11,18}, {3,5,12,15}, {3,5,12,16}, {3,5,12,17}, {3,5,12,18}, {3,5,13,15}, {3,5,13,16}, {3,5,13,17}, {3,5,13,18}, {3,5,14,15}, {3,5,14,16}, {3,5,14,17}, {3,5,14,18}, {3,5,19}, {3,5,20}, {3,6,11,15}, {3,6,11,16}, {3,6,11,17}, {3,6,11,18}, {3,6,12,15}, {3,6,12,16}, {3,6,12,17}, {3,6,12,18}, {3,6,13,15}, {3,6,13,16}, {3,6,13,17}, {3,6,13,18}, {3,6,14,15}, {3,6,14,16}, {3,6,14,17}, {3,6,14,18}, {3,6,19}, {3,6,20}, {3,7,11,15}, {3,7,11,16}, {3,7,11,17}, {3,7,11,18}, {3,7,12,15}, {3,7,12,16}, {3,7,12,17}, {3,7,12,18}, {3,7,13,15}, {3,7,13,16}, {3,7,13,17}, {3,7,13,18}, {3,7,14,15}, {3,7,14,16}, {3,7,14,17}, {3,7,14,18}, {3,7,19}, {3,7,20}, {3,8,11,15}, {3,8,11,16}, {3,8,11,17}, {3,8,11,18}, {3,8,12,15}, {3,8,12,16}, {3,8,12,17}, {3,8,12,18}, {3,8,13,15}, {3,8,13,16}, {3,8,13,17}, {3,8,13,18}, {3,8,14,15}, {3,8,14,16}, {3,8,14,17}, {3,8,14,18}, {3,8,19}, {3,8,20}, {4,5,11,15}, {4,5,11,16}, {4,5,11,17}, {4,5,11,18}, {4,5,12,15}, {4,5,12,16}, {4,5,12,17}, {4,5,12,18}, {4,5,13,15}, {4,5,13,16}, {4,5,13,17}, {4,5,13,18}, {4,5,14,15}, {4,5,14,16}, {4,5,14,17}, {4,5,14,18}, {4,5,19}, {4,5,20}, {4,6,11,15}, {4,6,11,16}, {4,6,11,17}, {4,6,11,18}, {4,6,12,15}, {4,6,12,16}, {4,6,12,17}, {4,6,12,18}, {4,6,13,15}, {4,6,13,16}, {4,6,13,17}, {4,6,13,18}, {4,6,14,15}, {4,6,14,16}, {4,6,14,17}, {4,6,14,18}, {4,6,19}, {4,6,20}, {4,7,11,15}, {4,7,11,16}, {4,7,11,17}, {4,7,11,18}, {4,7,12,15}, {4,7,12,16}, {4,7,12,17}, {4,7,12,18}, {4,7,13,15}, {4,7,13,16}, {4,7,13,17}, {4,7,13,18}, {4,7,14,15}, {4,7,14,16}, {4,7,14,17}, {4,7,14,18}, {4,7,19}, {4,7,20}, {4,8,11,15}, {4,8,11,16}, {4,8,11,17}, {4,8,11,18}, {4,8,12,15}, {4,8,12,16}, {4,8,12,17}, {4,8,12,18}, {4,8,13,15}, {4,8,13,16}, {4,8,13,17}, {4,8,13,18}, {4,8,14,15}, {4,8,14,16}, {4,8,14,17}, {4,8,14,18}, {4,8,19}, {4,8,20}, {9,11,15}, {9,11,16}, {9,11,17}, {9,11,18}, {9,12,15}, {9,12,16}, {9,12,17}, {9,12,18}, {9,13,15}, {9,13,16}, {9,13,17}, {9,13,18}, {9,14,15}, {9,14,16}, {9,14,17}, {9,14,18}, {9,19}, {9,20}, {10,11,15}, {10,11,16}, {10,11,17}, {10,11,18}, {10,12,15}, {10,12,16}, {10,12,17}, {10,12,18}, {10,13,15}, {10,13,16}, {10,13,17}, {10,13,18}, {10,14,15}, {10,14,16}, {10,14,17}, {10,14,18}, {10,19}, {10,20}										

TABLE III
COMPONENT RANKINGS AND METRIC VALUES FOR OPTION #2

comp.	mark	Birnbbaum		Criticality		Fussell-Vesely		RAW		RRW	
		rank	value	rank	value	rank	value	rank	value	rank	value
IL	1,7	5	0.026817	5	0.106440	5	0.110341	5	1.000081	1	1.027493
MCP	2,8	1	0.026980	1	0.321252	1	0.331022	1	1.000243	1	1.027493
SB	3,9	2	0.026871	2	0.177756	2	0.183901	2	1.000134	1	1.027493
II _L	4,10	5	0.026817	5	0.106440	5	0.110341	5	1.000081	1	1.027493
SP	5,11	4	0.026839	4	0.134932	4	0.139765	4	1.000102	1	1.027493
T	6,12	3	0.026844	3	0.142062	3	0.147121	3	1.000107	1	1.027493
minimal cut sets:	{1,7}, {1,8}, {1,9}, {1,10}, {1,11}, {1,12}, {2,7}, {2,8}, {2,9}, {2,10}, {2,11}, {2,12}, {3,7}, {3,8}, {3,9}, {3,10}, {3,11}, {3,12}, {4,7}, {4,8}, {4,9}, {4,10}, {4,11}, {4,12}, {5,7}, {5,8}, {5,9}, {5,10}, {5,11}, {5,12}, {6,7}, {6,8}, {6,9}, {6,10}, {6,11}, {6,12}										

TABLE IV
COMPONENT RANKINGS AND METRIC VALUES FOR OPTION #3

comp.	mark	Birnbaum		Criticality		Fussell-Vesely		RAW		RRW	
		rank	value	rank	value	rank	value	rank	value	rank	value
I _L	1,6	5	0.022451	5	0.007897	5	0.008195	5	1.000068	2	1.023097
MCP	2,7	2	0.022587	2	0.023833	2	0.024586	2	1.000205	2	1.023097
SB	3,8	3	0.022496	3	0.013187	3	0.013659	3	1.000113	2	1.023097
II _L	4,9	6	0.022439	6	0.006577	6	0.006829	6	1.000057	2	1.023097
SP	5,10	4	0.022469	4	0.010010	4	0.010381	4	1.000086	2	1.023097
T	11	1	0.999467	1	0.937452	1	0.937953	1	1.008065	1	Inf
minimal cut sets:		{1,6}, {1,7}, {1,8}, {1,9}, {1,10}, {2,6}, {2,7}, {2,8}, {2,9}, {2,10}, {3,6}, {3,7}, {3,8}, {3,9}, {3,10}, {4,6}, {4,7}, {4,8}, {4,9}, {4,10}, {5,6}, {5,7}, {5,8}, {5,9}, {5,10}, {11}									

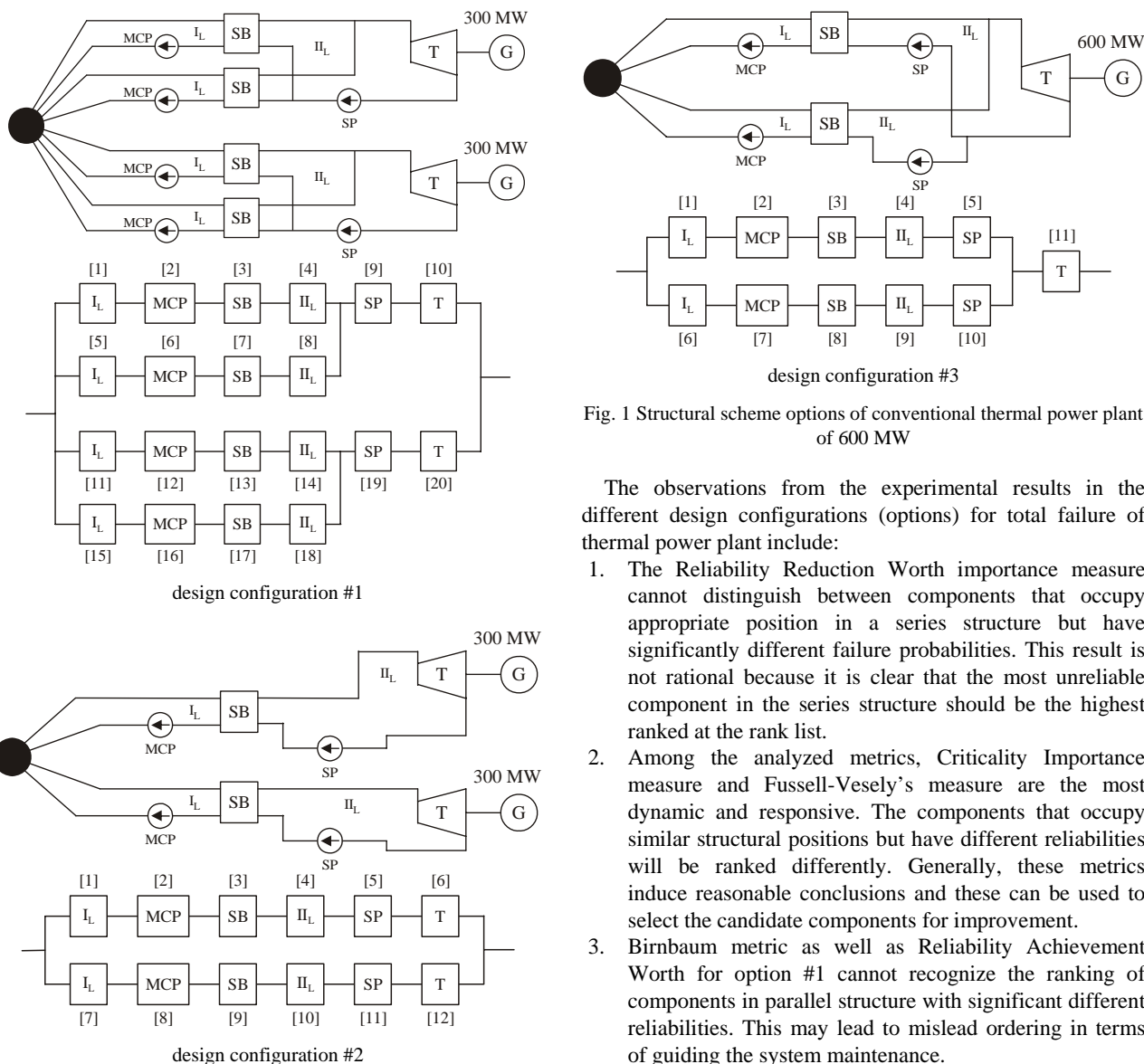

Fig. 1 Structural scheme options of conventional thermal power plant of 600 MW

The observations from the experimental results in the different design configurations (options) for total failure of thermal power plant include:

1. The Reliability Reduction Worth importance measure cannot distinguish between components that occupy appropriate position in a series structure but have significantly different failure probabilities. This result is not rational because it is clear that the most unreliable component in the series structure should be the highest ranked at the rank list.
2. Among the analyzed metrics, Criticality Importance measure and Fussell-Vesely's measure are the most dynamic and responsive. The components that occupy similar structural positions but have different reliabilities will be ranked differently. Generally, these metrics induce reasonable conclusions and these can be used to select the candidate components for improvement.
3. Birnbaum metric as well as Reliability Achievement Worth for option #1 cannot recognize the ranking of components in parallel structure with significant different reliabilities. This may lead to mislead ordering in terms of guiding the system maintenance.
4. When Birnbaum metric is high and the basic components unavailability already fairly low, one could think of introducing extra redundancy.

IV. CONCLUSION

The analysis of the thermal power plants reliability is

frequently based on simple indexes that do not take into account the criticality of some failures. This criticality should be evaluated on reliability concepts that consider the effect of a component failure on the power plant performance. Although reliability importance measure have been developed for the power industry and applied in transmission and distribution systems, it can be useful metrics to rank components regarding their impact on power plant reliability, operation and maintenance. These analyzed measures serve as very useful tools for reliability improvement components and as very valuable information for decision-makers to evaluate where investments could be made in order to improve the functioning and reliability of the power plant.

Bosnia and Herzegovina. His areas of interest include operation, planning and economics of electric power systems and application of reliability theory to electric power systems.

Mensur Hajro received the degree of Electrical Engineer in 1972 from the Faculty of Electrical Engineering, University of Sarajevo, M.Sci. degree in 1980 from Faculty of Electrical Engineering, University of Zagreb (Croatia) and Ph.D. degree in 1989 from the Faculty of Electrical Engineering, University of Sarajevo, Bosnia and Herzegovina. He is currently a full professor at the Faculty of Electrical Engineering, University of Sarajevo, Bosnia and Herzegovina. His research interests include operation, planning and economics of electric power systems.

Mersiha Samardzic is student at the Faculty of Electrical Engineering, University of Sarajevo, Bosnia and Herzegovina. Her research interests include computer simulations and design analysis applied to electric power systems.

REFERENCES

- [1] M. van der Borst, and H. Schoonakker, "An overview of PSA importance measures", *Reliability Engineering and System Safety*, ELSEVIER, vol. 72, pp. 241-245, 2001.
- [2] L. Lu, and J. Jiang, "Probabilistic safety assessment for instrumentation and control systems in nuclear power plants: An overview", *Journal of Nuclear Science and Technology*, vol. 41, no. 3, pp. 323-330, 2004.
- [3] W. Wendai, J. Loman, and P. Vassiliou, "Reliability importance of components in a complex system", in: *IEEE Proceedings of Annual Reliability and Maintainability Symposium*, Los Angeles California, 2004.
- [4] J. F. Espiritu, D. W. Coit, and U. Prakash, "Component criticality importance measures for the power industry", *Electric Power Systems Research*, ELSEVIER vol. 77, pp. 407-420, 2007.
- [5] G. Hamoud, L. Lee, J. Toneguzzo, and G. Watt, "Assessment of component criticality in customer delivery systems", in: *Proceedings of the Eighth International Conference on Probabilistic Methods Applied to Power Systems*, Iowa State University, Ames, Iowa, 2004.
- [6] P. Hilber, and L. Bertling, "Monetary importance of component reliability in electrical networks for maintenance optimization", in: *Proceedings of the Eighth International Conference on Probabilistic Methods Applied to Power Systems*, Iowa State University, Ames, Iowa, 2004.
- [7] J. E. Ramirez-Marquez, and D. Coit, "Composite importance measures for multi-state systems with multi-state components", *IEEE Transactions on Reliability*, vol. 54, no. 3, pp. 517-529, 2005.
- [8] J. E. Ramirez-Marquez, C. M. Rocco, B. A. Gebre, D. W. Coit, and M. Tortorella, "New insights on multi-state component criticality and importance", *Reliability Engineering and System Safety*, ELSEVIER, vol. 91, pp. 894-904, 2005.
- [9] W. Wang, J. Loman, and P. Vassiliou, "Reliability importance of components in a complex system", *IEEE Proceedings of Annual Reliability and Maintainability Symposium*, Los Angeles, California, USA, 2004.
- [10] M. Rausand, and A. Hoyland, *System reliability theory – models, statistical methods and applications*, 2nd edition, John Wiley & Sons, New York, Inc, 2004.
- [11] A. Gandini, "Importance and sensitivity analysis in assessing system reliability", *IEEE Transactions on Reliability*, vol. 39, no. 1, pp. 61-70, 1990.
- [12] G. Levitin, L. Podofillini, and E. Zio, "Generalized importance measures for multistate elements based on performance level restrictions", *Reliability Engineering and System Safety*, ELSEVIER vol. 82, pp. 63-73, 2003.
- [13] G. F. M. de Souza, *Thermal power plant performance analysis*, Springer, London, 2012.
- [14] S. Bisanovic, and H. Sehovic, "Optimal reliability of power capacities in the phase of preparation and design", *International Journal of Reliability and Safety*, Inderscience Publishers, vol. 2, no. 4, pp. 340-356, 2008.

Smajo Bisanovic received the degree of Electrical Engineer in 1991, M.Sci. degree in 1994 and Ph.D. degree in 2009 from the Faculty of Electrical Engineering, University of Sarajevo, Bosnia and Herzegovina. He is assistant professor at the Faculty of Electrical Engineering, University of Sarajevo,