

# Comparison of Material Constitutive Models Used in FEA of Low Volume Roads

Lenka Ševelová, Aleš Florian

**Abstract**—Appropriate and progressive tool for analyzing behavior of low volume roads are probabilistic models used in reliability analyses. The necessary part of the probabilistic model is the deterministic model of structural behavior. The FE model of low volume roads is created in the ANSYS software. It is able to determine the state of stress and deformation in any point of the structure and thus generate data required for the reliability analysis. The paper compares two material constitutive models used for modeling of unbound non-homogenous materials used in low volume roads. The first model is linear elastic model according to Hook theory (H model), the second one is nonlinear elastic-plastic Drucker-Prager model (D-P model).

**Keywords**—FEA, FEM, geotechnical materials, low volume roads, material constitutive models, pavement.

## I. INTRODUCTION

LOW volume roads form a significant percentage in the total traffic network of both the economically advanced and developing countries. These pavement structures are very specific due to utilizing unbound materials that are used in the whole construction. Specifics of low volume roads and their growing significance in the transport system place a special attention on optimizing the design of these multi-functional roads. Road - a multi-layer construction that works together with the subgrade - must provide safe and efficient operation of motor vehicles for the required life at a given intensity of the traffic. The today's standard design methods for dimensioning low volume roads are based on knowledge of the California Bearing Ratio (CBR) of subgrade, empiricism and experiment. Experimental measurements and tests provide very important data e.g. about the influence of load and climatic effects on the road. However they must be carried out on a real structure, which is very expensive. Also they do not allow to analyze the state of stress in the construction system pavement - subgrade, they are not able to evaluate the effects of overloading and also they cannot predict the behavior of pavements made from new alternative materials (e.g. recycled ones).

Appropriate and progressive tool for analyzing these problems are probabilistic models used in reliability analyses [1]-[3]. They allow investigating of interaction between the individual components of the system pavement - subgrade, to

quantify the degree of influence of individual input parameters on the structural behavior as well as to include the random variability of input variables into calculations. The necessary part of any probabilistic model is the appropriate deterministic numerical model used for calculating output data. The aim is to create a suitable numerical model of low volume roads which would be able to determine the state of stress and deformation at any point of the pavement and thus generate data required for the reliability analysis. The main attention is given to the selection of an adequate material constitutive model of the soil and generally of all unbound materials which will include the most important physical phenomena occurring in the non-homogenous material with sufficient accuracy.

Numerical models of structures are currently mostly based on the finite element method (FEM) due to its universality for the solution of various physical phenomena in many fields of science. The paper presents partial results carried out in the calibration process of the developed FE model for modeling low volume roads to compare the two material constitutive models - linear elastic material model according to Hook theory (the H model) and nonlinear elastic-plastic Drucker-Prager model (the D-P model).

## II. MATERIAL CONSTITUTIVE MODEL OF UNBOUND NON-HOMOGENOUS MATERIALS

The FE model of pavement is developed in ANSYS ver. 13 software system [4]. According to the actual research, material constitutive models are among the most important and at the same time the most problematic parts of any geotechnical structural analysis. The main problem seems to be the description of nonlinear soil behavior using appropriate material characteristics and the subsequent material model calibration. Also some more complex models require laboratory experiments that are normally not carried out and can hardly be used in everyday geotechnical practice. ANSYS software offers a variety of different material constitutive models. With regard to the practical use and demands of preparation of input values two main groups of material constitutive models are examined. From the group of linear models the basic elastic model according to Hook theory (the H model) is selected. From nonlinear models the elastic-plastic Drucker-Prager model (the D-P model) is chosen.

L. Ševelová is with the Department of Landscape Formation and Protection, Mendel University of Brno, Czech Republic (e-mail: lenka.sevelova@mendelu.cz).

A. Florian is with the Faculty of Civil Engineering, Brno University of Technology, Czech Republic (phone: +420-541147378; e-mail: florian.a@fce.vutbr.cz).

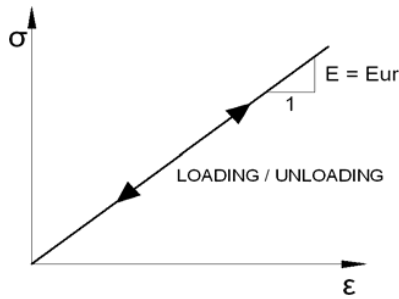

Fig. 1 H model idealization

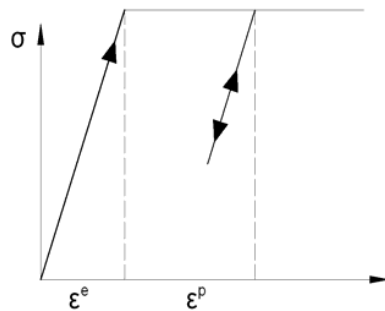

Fig. 2 D-P model elastic-plastic idealization

#### A. Linear Elastic Material Model - H Model

Linear elastic material model is the basic and the most widely used material model that is based on the linear relation between stress and strain given by the Hook law. The H model is defined for an ideal material with immediate response where the load does not exceed the limit of proportionality and where only elastic strains are expected. During loading and unloading the material behaves according to idealized stress-strain diagram, see Fig. 1, where the loading described by modulus of elasticity  $E$  follows the same curve as the unloading expressed by the modulus  $E_{ur}$ . The H model does not consider material hardening and the yield strength - the maximum shear stress  $\tau_{max}$  for soils - is not defined.

The necessary ANSYS software input parameters for this model are - material density -  $\rho$ , Poisson coefficient -  $\nu$ , and modulus of elasticity -  $E$ . The modulus of elasticity  $E = E_{ur}$  is defined as the initial tangential modulus of the stress-strain diagram.

#### B. Nonlinear Elastic-Plastic Material Model - D-P Model

Drucker-Prager material model describes materials with pressure-dependent inelastic behavior. It contains a dependence on hydrostatic stress. This behavior is considered as instantaneous and time-independent. The idealized stress-strain diagram of elastic-plastic material is shown in Fig. 2.

To describe the behavior of soils and other unbound materials it is necessary to define the plasticity limit which in the multidimensional state of stress is generalized by the yield surface that defines the area separating elastic and plastic zones in the material body. For D-P model, if the yield surface is plotted in principal stress space, it will look like a cone, as shown in Fig. 3. This area is dependent on the advancing

plasticization process and after exceeding the yield strength - the maximum shear stress  $\tau_{max}$  for soils - the resulting plastic strain is irreversible.

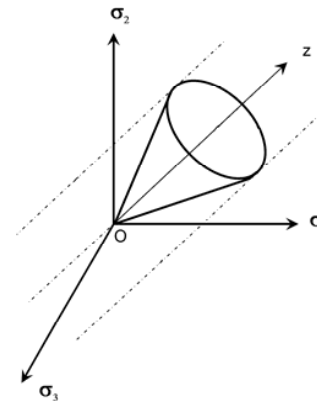

Fig. 3 Yield surface of D-P model

The necessary ANSYS software input parameters for this model are - modulus of elasticity -  $E$ , Poisson coefficient -  $\nu$ , material density -  $\rho$ , angle of internal friction -  $\phi$ , cohesion value -  $c$ , and dilatancy angle -  $\psi$ . The modulus of elasticity  $E$  is also defined as the initial tangential modulus.

### III. FINITE ELEMENT MODEL OF PAVEMENT

The ANSYS software system [4] is divided into individual modules that, with the parametric definition of the model, allow simultaneous processing of deterministic and reliability parts of the solution. In the parametric model individual steps of the creation and solution of the model as well as desired output data for probabilistic processing are defined with suitably chosen input parameters using the internal language APDL (ANSYS Parametric Design Language) [4]. Parametric definition of input parameters allows changing easily the dimensional and material arrangement, boundary conditions of the model and outputting settings needed for the probabilistic analysis. For this type of analysis additional definition of the input and output random variables and choice of numerical simulation techniques is required. ANSYS system explicitly offers Monte Carlo method or Latin Hypercube Sampling method [5] and alternatively so called USER method that uses input data generated directly by the user defined method, e.g. Updated Latin Hypercube Sampling method [6].

Parametric FE model of the pavement - subgrade system, see Fig. 4, is created as the 2D planar model in the working plane XY. The FE mesh is created by four-node element PLANE 82 [4] that has two degrees of freedom - displacement UY and UY - at each node. The contact between the structural layers is assumed as perfectly bonded. The calculation is carried out according to the theory of plane strain. In the case of D-P model the FEM model of pavement is nonlinear and thus Newton-Raphson method is used for solution of nonlinear system of equations.

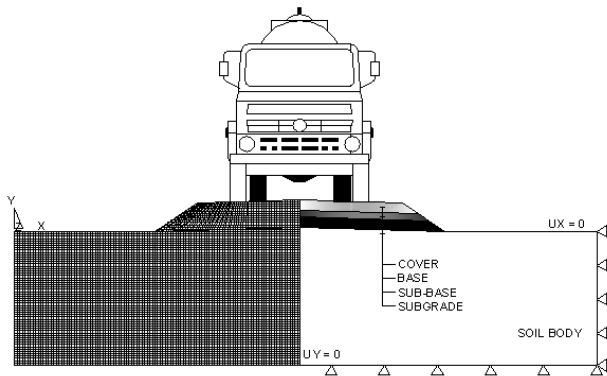

Fig. 4 Scheme of the model geometry, FE mesh

Four groups of input parameters (158 parameters total) are defined:

- Geometrical parameters - 47 parameters defining the geometrical and dimensional (m) arrangement of the pavement - subgrade layers and the dimensions of FE mesh,
- Boundary conditions parameters – 6 parameters defining the support of the model, position and intensity of the load,
- Material parameters - 39 parameters defining the modulus of elasticity (Pa), Poisson coefficient (-), material density (kNm-3), angle of internal friction ( $^{\circ}$ ), cohesion value (Pa) and dilatancy angle ( $^{\circ}$ ) of construction materials,
- Output parameters - 66 parameters defining the desired output values at selected points of FE mesh
- Horizontal stress SX (Pa), vertical stress SY (Pa), shear stress SYX (Pa) and vertical displacement (deflection) UY (m).

TABLE I  
INPUT VALUES FOR FEA

Layer	Thickness h [m]	Material Density $\rho$ [kg/m <sup>3</sup> ]	Poisson Coefficient $\nu$ [-]	Modulus of Elasticity $E_{min}$ [MPa]	Modulus of Elasticity $E_{max}$ [MPa]
Cover	0,180	2000	0,2	300	300
Base	0,200	2000	0,4	80	80
Sub-base	0,150	2000	0,4	80	80
Sub-grade	10,000	1950	0,4	1	30

All stress components are calculated on the contacts of the individual layers and in the center of each layer. Boundary conditions are defined on both vertical edges and on the lower horizontal edge of the FE model. On the vertical edges the horizontal displacement (X axis direction) is set to zero and on the lower horizontal edge the vertical displacement (Y axis direction) is set to zero. The lower horizontal edge is placed in the depth of 10m.

To simulate the standardized experimental test loading by circular plate, the contact pressure of intensity  $p = 650$  kPa that acts on ideal circular area with a radius of  $r = 0.1565$ m is converted into the load  $F = 50$  kN. No dynamic load is considered. Generally, traffic loading effects caused by motor

vehicles moving at the speed in the range of 30 – 50 km.h-1 can be supposed as temporary of a short-term nature with the short-term dynamic and the short-term static components. The dynamic load component increases the loading intensity and lengthens the response. These effects, however, disappear faster than those caused by the static load component. Also the static load component causes stresses that affect greater depths than those caused by the dynamic load component. But all these effects are generally smaller than the stresses caused by the permanent load (self-weight of materials) - so called geostatic stresses. Thus, the specific character of traffic on low volume roads that is limited by low speeds and accompanied by slow taxing and standing allow taking into account only the short-term static component of the traffic loading.

The solution procedure is divided into 8 partial load increments - load cases - T1 to T8 to allow tracking of stress changes in the course of pavement construction and thus to simulate the construction process with gradual loading by separate pavement layers finished by the external traffic loading. In the load cases T1 to T7, where only the self-weight of materials is acting, geostatic stresses  $\sigma_{or}$  are calculated. In the load case T8 external load join in and interaction of all loading effects ( $\sigma_{or} + \sigma$ ) comes in. It is possible to obtain the defined output parameters (stresses, deflection) individually from each load case (T1 to T8) and to determine changes in stresses and deflection caused e.g. by using different materials or external loads of different intensity.

TABLE II  
INPUT VALUES FOR FEA

Layer	Cohesion Value c [kPa]	Angle of Internal Friction $\phi$ [ $^{\circ}$ ]	Dilatancy Angle $\psi$ [ $^{\circ}$ ]
Cover	3	2000	0,2
Base	5	2000	0,4
Sub-base	5	2000	0,4
Sub-grade	10	1950	0,4

#### IV. PAVEMENT ANALYZED

For comparing two material constitutive models the typical low volume road widely used as a haul forest road in Czech Republic is chosen. The pavement consists of four structural layers:

1. cover - mechanically compacted mixture of natural stone,
2. base - coarse-fine crushed aggregate,
3. sub-base - soil mechanically improved with stone,
4. subgrade - original soil.

Dimensions and input material values used in H model and D-P model are listed in Tables I and II. They are taken from current standards and also based on professional judgment. Subgrade modulus of elasticity is given in the interval from minimal  $E_{min} = 1$  MPa to maximal value  $E_{max} = 30$  MPa to enable evaluation of the models behavior under different subgrade quality levels from very low to fair. For each material model - H model and D-P model - twenty calculations (studies) with different values of subgrade modulus of elasticity in the range  $E_{min} - E_{max}$  are performed. In H model, all materials are modeled as linear elastic. In D-P

model, all materials are modeled as nonlinear elastic-plastic.

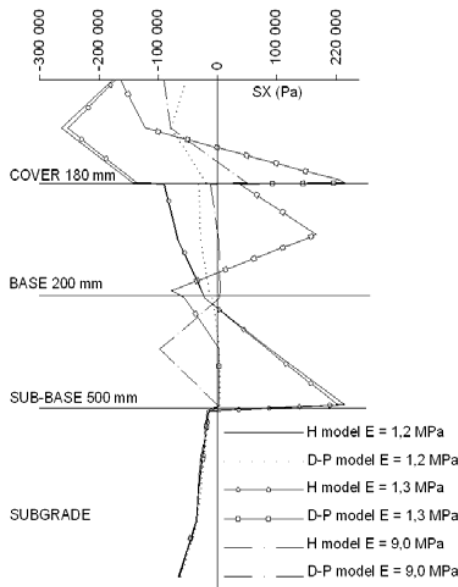

Fig. 5 Stress SX along the pavement thickness

V. RESULTS

To compare both material models the normal stresses in horizontal direction SX and vertical direction SY as well as deflection UY are analyzed. Stresses are evaluated on the vertical axis of the applied load in the middle of each structural layer and on the contact of layers. In the subgrade they are evaluated in four explicitly defined depth levels. Thus we are able to analyze stresses along the whole thickness of the structure analyzed and also on the contact of structural layers.

Compressive stress has negative sign while tensile stress has positive sign.

For the sake of brevity only some illustrative results are shown in Figs. 5 and 6. In Fig. 5 the stresses in horizontal direction SX along the pavement thickness for three representative values of subgrade modulus of elasticity of E = 9MPa, E = 1.3MPa and limiting E = 1.2MPa (the load capacity of subgrade material) are shown. The same is shown for stresses in vertical direction SY in Fig. 6.

The more significant differences in the stress behavior obtained from the material models depending on the value of E modulus show horizontal stresses SX, see Fig. 5. Extreme compressive stress arises in both material models and for all values of the E modulus in the area around the applied load. Stresses obtained from D-P model are generally smaller than those obtained from H model especially for small values of E modulus. For higher values of E modulus above 9MPa the stresses obtained from both models are more or less of the same value. In the subgrade, there is no difference in stresses SX calculated from both models with arbitrary value of E modulus. From the numerical point of view, the D-P model needs higher number of Newton-Raphson iteration for low

values of E modulus and some convergence problems occur for very low value of E = 1,2 MPa.

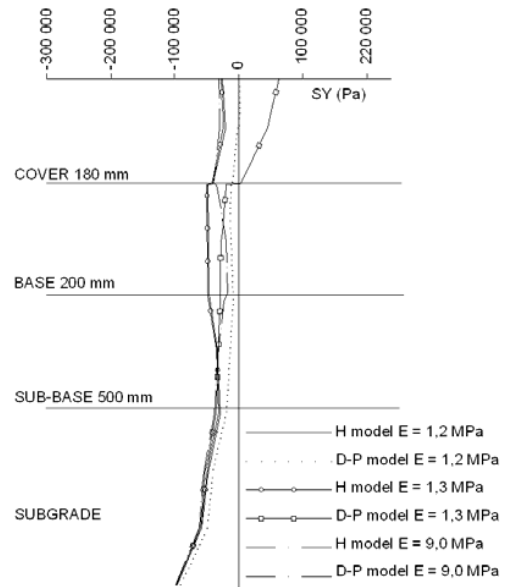

Fig. 6 Stress SY along the pavement thickness

In the case of SY stresses the both models show relatively identical behavior especially for higher values of E modulus above 9MPa, see Fig. 6. SY stresses obtained from H model are only compressive stresses in all layers and for all values of E modulus. In the D-P model SY stresses show with the decreasing value of E modulus a different behavior in the upper structural layers and for very low values the stresses change into tension.

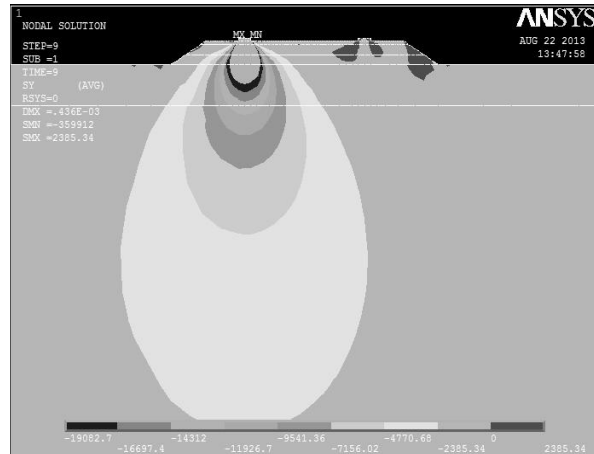

Fig. 7 SY stresses distribution for H model, E = 9MPa

The SY stresses distribution in 2D FEM model for H model and for E = 9MPa is shown in Fig. 7. The SX stresses distribution for D-P model and for E = 30MPa is shown in Fig. 8.

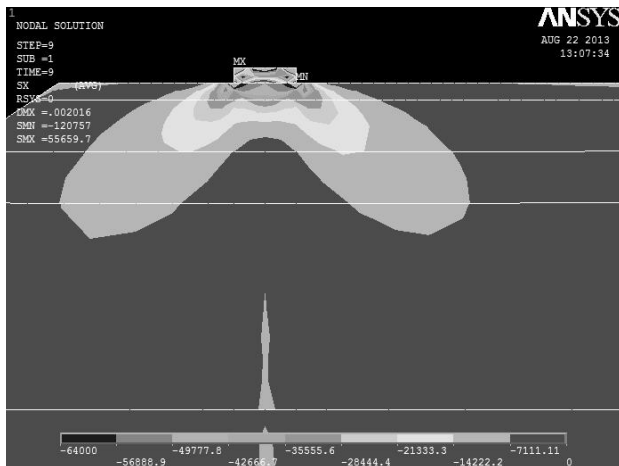

Fig. 8 SX stresses distribution for D-P model,  $E = 30\text{MPa}$

## VI. CONCLUSION

To analyze behavior of low volume roads in detail the probabilistic model used in reliability analyses is proposed. The necessary part of this type of analysis is the deterministic model of pavement behavior that is able to determine the state of stress and deformation in any point of the structure and thus generate data required for the reliability analysis. The paper compares two material constitutive models used in FE model of low volume roads for modeling of unbound non-homogenous materials. The first model is linear elastic model according to Hook theory (H model), the second one is nonlinear elastic-plastic Drucker-Prager model (D- P model).

Taking into account the theoretical background of both models the D-P model is able to describe the nonlinearities in soil behavior after loading more accurately. As proved in the study, it is correct especially for low quality subgrade with low modulus of elasticity. For other subgrade quality with higher modulus of elasticity the simple H model provides the same results. For the pavement analyzed the threshold level of modulus of elasticity is the value of 9 MPa. Also should be noted, that for subgrade with very low quality the D-P model shows problems with convergence of solution of nonlinear equations.

## ACKNOWLEDGMENT

The research was supported by the project TA01020326 "Optimization of design and realization of low capacity road pavements" of the Technology Agency of Czech Republic.

## REFERENCES

- [1] S. F. Wojtkiewicz, L. Khazanovich, G. Gaurav, and R. Velasquez, "Probabilistic Numerical Simulation of Pavement Performance using MEPDG," *Road Materials and Pavement Design*, vol. 11, no. 2, pp. 291-306, 2010.
- [2] S. W. Lee, J. H. Jeong, and B. J. Chon, "Probabilistic Modeling of Pavement Joint Opening," *Proc. of the Institution of Civ. Eng. Transport*, vol. 163, no. 1, pp. 9-17, 2010.
- [3] A. Florian, L. Ševelová, and R. Hela, "Reliability Analysis of Deflections of Concrete Pavement," in *Proc. of the 2nd Int. Conference on Best Practices for Concrete Pavements IBRACON 2011*, Florianopolis, Brazil, 2011, pp. 1-10.

- [4] www.ansys.com.
- [5] M. McKay, R. J. Beckman, and W. J. Conover, "A Comparison of Three Methods for Selecting Values of Input Variables in the Analysis of Output from a Computer Code," *Technometrics*, no. 2, pp. 239-245, 1979.
- [6] A. Florian, "Optimization of parametric studies using Updated Latin Hypercube Sampling," in *Proc. of the ICOSSAR 2005*, Rome, Italy, 2005, pp. 2319-2323.