

Comparative Study of QRS Complex Detection in ECG

Ibtihel Nouira, Asma Ben Abdallah, Ibtissem Kouaja, and Mohamed Hèdi Bedoui

Abstract—The processing of the electrocardiogram (ECG) signal consists essentially in the detection of the characteristic points of signal which are an important tool in the diagnosis of heart diseases. The most suitable are the detection of R waves. In this paper, we present various mathematical tools used for filtering ECG using digital filtering and Discrete Wavelet Transform (DWT) filtering. In addition, this paper will include two main R peak detection methods by applying a windowing process: The first method is based on calculations derived, the second is a time-frequency method based on Dyadic Wavelet Transform DyWT.

Keywords—Derived calculation methods, Electrocardiogram, R peaks, Wavelet Transform.

I. INTRODUCTION

THE electrocardiogram (ECG) signal reflects the electrical activity of the heart muscle. It is characterized by five separate waves designated as P, Q, R, S and T that shown in Fig. 1. These waves are related to the rhythmic electrical depolarization and repolarization of the atria and ventricles.

The Frequencies for each wave provide variations depending on the heart rate. The change in the rate of beat is called Arrhythmia. The frequency band of the ECG signals is approximately 50 to 100 Hz for a normal subject.

The RR distance between the R peaks is generally chosen for the detection of the cardiac arrhythmia, such as an irregular heart rate. A heart rate is regular if it is of the order of 60 beats per minute; otherwise, it's called bradycardia (heart rate <50 beats / mn and the distance $RR > 1.2s$) or tachycardia (heart rate > 100 beats / mn and the distance $RR < 0.6s$).

In this context, various studies have been conducted. For example, in the derivative based methods [1]-[2]-[3], to detect the R peaks, the authors use the first derivative (respectively second derivative in [4]). They locate for this purpose, the complex QRS by the thresholding of the derivative. Other works exploit nonlinear analysis methods, especially the neural networks [5] and non-stationary analysis tools such as wavelets that are the most used [6]-[7]-[8].

I. Nouira is with the TIM Team, Biophysics Laboratory, Medicine Faculty of Monastir, 5019 Monastir, Tunisia (phone: +216 50 852 880; e-mail: ibtihelnouira@gmail.com).

A. Ben Abdallah S is with the TIM Team, Biophysics Laboratory, Medicine Faculty of Monastir, 5019 Monastir, Tunisia (e-mail: asma.babdallah@crystal.rnu.tn).

I. Kouaja is with the TIM Team, Biophysics Laboratory, Medicine Faculty of Monastir, 5019 Monastir, Tunisia (e-mail: ibtissem.khouaja@live.fr).

M. H. Bedoui is with the TIM Team, Biophysics Laboratory, Medicine Faculty of Monastir, 5019 Monastir, Tunisia (e-mail: medhedi.bedoui@fmm.rnu.tn).

Our work fits into this context. This is to provide a tool for the detection of RR series that implements the methods based derivative [1]-[2]-[3]-[4] and those based on the Dyadic Wavelet Transform (DyWT) and which overcomes the disadvantages of these approaches [6]-[7]-[8]. More specifically, in order to reduce the sensitivity to noise, we use a bandpass filtering which based respectively on high pass and low pass filters. This phase is based on two methods. The first is the implementation of a digital filtering that is applied before the R peaks detection by the derived methods. The second is the development of a low pass filter based on Discrete Wavelet Transform DWT (Db2) and a high pass filter based on DWT (Db11) that are applied before the R peaks detection by the DyWT method. Our contribution is situated at this phase of pretreatment by the DWT: for each of the used filters, the decomposition level is calculated in an automatic manner basing on the sampling frequency and the bandwidth of the ECG signal. Once the signal is purified, we develop the phase of R peaks detection. To solve the problem of thresholding and false detections caused by the variability in the morphology of the R peaks, we propose to apply a window on the ECG signal. To validate our work, we apply it on real data which are relative to nine subjects (healthy and pathological). A comparison between the results will be given.

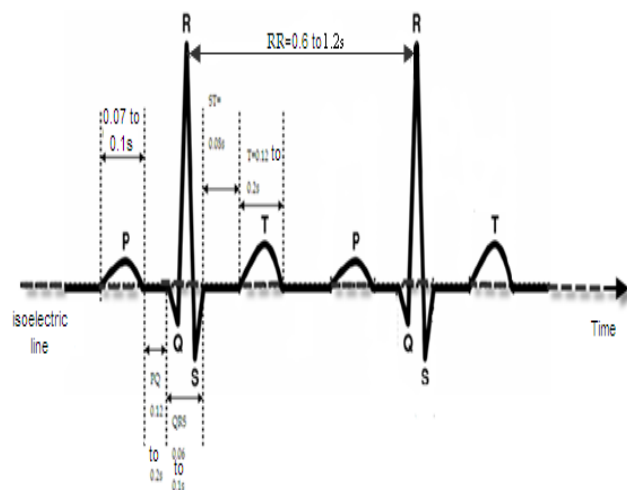

Fig. 1 Standard waves of a normal electrocardiogram

II. WAVELET TRANSFORM

The Continuous Wavelet Transform (CWT) is the continuous sum over the entire time interval of signal $x(t)$ multiplied by the shifted and the extended or reduced versions of the mother function $\psi(t)$. The CWT is defined by (1):

$$C(a, b) = \int_{-\infty}^{\infty} x(t)\psi_{a,b}(t)dt \frac{1}{\sqrt{a}} \int_{-\infty}^{\infty} x(t)\psi\left(\frac{t-b}{a}\right)dt \quad (1)$$

Where ψ is the mother wavelet, a is the scale factor and b is the translation parameter.

The continuity of the CWT in the plan of the translation parameter - scale factor is translated by a long calculation time which requires the discretization of the scale factor a and the translation parameter b by a suitable sampling grid as in (2), this transform is called dyadic wavelet transform DyWT.

$$a = 2^j \text{ et } b = k.2^j$$

$$DyWT_x^\psi(j, k) = C_{j,k} = 2^{-j/2} \int_{-\infty}^{\infty} x(t)\psi\left(\frac{t-k}{2^j}\right)dt \quad (2)$$

Where j and k are two integers

The discretized form of the CWT, described by (1) is the Discrete Wavelet Transform DWT. The DWT is based on the use of the complementarity of the two filters, low pass filter $h(n)$ and a high pass filter $g(n)$ (Fig. 2) [9].

Several levels of decompositions are possible. At every level the signal is decomposed into two components, the one representing the general shape of the signal or low frequency components, it is the "approximation" cA_j . The other one representing short and quick events or high frequency components, they are "details" cD_j . The approximation and details coefficients are respectively defined by (3) and (4):

$$cA_{j+1}(k) = \sum_{n=-\infty}^{\infty} h(n - 2k)cA_j(n) \quad (3)$$

$$cD_{j+1}(k) = \sum_{n=-\infty}^{\infty} g(n - 2k)cA_j(k) \quad (4)$$

Where j is the decomposition level

The reconstruction is assured by the Inverse Wavelet Transform IDWT by using the synthetic filters \bar{h} and \bar{g} .

$$x(t) = cA_j(k) = \sum_{n=-\infty}^{\infty} cA_{j+1}(n) \bar{h}(k - 2n) + \sum_{n=-\infty}^{\infty} cD_{j+1}(n) \bar{g}(k - 2n) \quad (5)$$

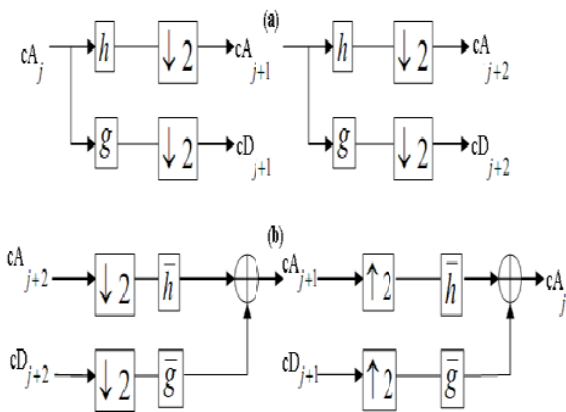

Fig. 2 Filter bank trees of: (a) decomposition (DWT), (b) reconstruction (IDWT)

III. METHODS OF DETECTION OF R PEAKS

The method of detection of the R peaks that we propose is composed of two phases that are: pretreatment and detection.

A. Pretreatment of ECG Signal

For a good detection and localization of the R peak, we will develop filtering methods before the application of detection methods. In fact, during the recording of ECG signals, different types of noise from various sources (artifacts, reversal of the extremities or chest leads, calibration of the device ...) can be superimposed to the original signal. The ECG signal conditioning is required to extract a useful signal from the signal buried in noise. Most sounds are located at frequencies that are below 1.5 Hz and above 50 Hz [10]. Therefore, the solution is filtering the ECG signal by a band pass filter or by high pass filter in a cascade with the low pass filter which their cutoff frequencies are respectively equal to the two preceding frequencies. In fact, the application of high pass filter eliminates baseline variations and the application of low pass filter removes high frequency noise.

In this section, two types of filter will be competing: filtering by a digital filter and by an application of the Daubechies wavelet to estimate the degree of the filtering quality.

1. Digital Filtering

A low pass filter $H_1(z)$ in series with a filter $H_2(z)$ or a filter $H_3(z)$ are applied to denoise the ECG signal [11]. The transfer functions and frequency characteristics of these filters are given in Table I.

TABLE I
EXAMPLES OF SOME LOW PASS AND HIGH PASS FILTERS

Transfer function	Nature of the filter	Gain	Cutoff frequency (3 dB)
$H_1(z) = \frac{1 - z^{-6} + z^{-12}}{1 - 2z^{-1} + z^{-12}}$	Low pass	36	20 Hz
$H_2(z) = \frac{-1 + 32z^{-16} - 32z^{-17} + z^{-32}}{32 - 32z^{-1}}$	High pass	1	8,5 Hz
$H_3(z) = z^{-127} \left[\frac{1 - z^{-128}}{2^7} \frac{1 - z^{-1}}{1 - z^{-1}} \right]^2$	High pass	1	1,62 Hz

Digital filters act on the gain, the waveform and location. Therefore, they can be used for the extraction of some parameters, in particular the determination of the distance RR or the number of QRS in a sequence. They are suitable especially for counting pulses as QRS because the P and T waves can be mitigated and the QRS complex is enhanced.

2. Wavelet Filtering

The principle of wavelet filtering is based on the decomposition of ECG signal by the DWT by choosing the mother wavelet ψ and the scale factor which give the best results. The works that have used this technique [12]-[13] differ in the choice of the mother function and the scale factor. In these works, the choice of scale is empirical.

In our case, the determination of the scale factor which optimizes the purification of the signal is automatically realized. In fact, it is calculated through two parameters: the sampling frequency and the knowledge of the bandwidth of the ECG signal. The scale parameter is specific to each filter (high and low pass filters). Thus, in the case of a sampling frequency of 256 Hz, the automatic calculation of optimal scale gives the order six for high pass filtering and order two for the low pass filtering.

To determine the choice of the mother wavelets, we based on a comparative study that we realized on various types of mother functions (coiflet, symlet, Daubechies). The best results obtained are the use of the Db11 mother wavelet in the case of high pass filtering and Db2 wavelet in the case of low pass filtering.

The high pass filter is constituted by three steps. In the first step, the original ECG signal is decomposed by DWT at level six. The second step is to remove the last approximation coefficients that correspond to low frequencies, zone of the baseline variations. Finally, we calculate the IDWT by using the new coefficients to reconstruct the signal where the variations of the baseline are eliminated.

The low pass is constituted by four stages. The first step is to decompose the ECG signal by DWT at level 2 and get the detail coefficients. In the second step, we calculate the mean μ (6) from the absolute values of the first detail coefficients $cD_1(k)$ then the standard deviation σ (7).

$$\mu = \frac{1}{N} \sum_{n=-\infty}^{\infty} \text{Abs}(cD_1(n)) \quad (6)$$

Where N is the number of the detail coefficients cD_1 .

$$\sigma = \frac{\mu}{0.6745} \quad (7)$$

Where 0.6745 is an empirical value used to calibrate the mean with standard deviation for a Gaussian process [14].

The threshold value is described by (8):

$$S = \sigma \sqrt{2 \ln(N)} \quad (8)$$

Then, we select the detail coefficients (cD) which is above the calculated threshold S using (9):

$$cD_i \text{ Chang}(k) = \begin{cases} cD_i(k) - (\text{sign}(cD_i(k)) \cdot S) & \text{if } cD_i(k) > S \\ 0 & \text{if } cD_i(k) \leq S \end{cases} \quad (9)$$

Finally, in the fourth step we compute the IDWT using the new coefficients to reconstruct the denoised signal.

With a sampling frequency of 256Hz, the selected frequencies range of the filtered signal varies in the range 2 Hz and 32 Hz.

B. R Peaks Detection

After the pretreatment of ECG Signal, we develop R peak detection methods based on derived calculations and the DyWT.

To solve the problem of variation in the morphology of the

R peaks, we propose to develop all detection methods on a time windowed portion of an ECG signal. The window allows the reduction of false detections. Thus the detection of R peaks will be limited on small intervals of time, in which these peaks do not admit a large variability in its morphology.

1. Methods Based On Derived Calculations

R peak Detection algorithms based on derived calculation are chosen on the basis of the literature with particular reference [1]-[2]-[3]-[4]. They have been developed in their adding the process of windowing.

The method proposed by W.P. Holsinger aims to seek a point of the derivative of the ECG signal that exceeds a given threshold ($S = 0.45 * \text{max amplitude of the derived signal}$) [2]. R peak is detected, if successif three points exceed the threshold S.

The method of Fraden and Neuman [3] is a variant of the Holsinger method, the authors proposed first to refocus the signal and then use a threshold ($S1 = 0.4 * \text{max amplitude of the refocused signal}$). The absolute value signal is then thresholded by refocused S1 and the derivative of the signal is then calculated. A R peak is detected when a point of the derivative exceeds the threshold S2 ($0.7 * \text{max amplitude of the derived signal}$).

For calculating the derivative of the ECG signal, A. Menard proposed using the following formula [1]:

$$\text{Derived}(i) = -2 * \text{signal}(i - 2) - \text{signal}(i - 1) + \text{signal}(i + 1) + 2 * \text{signal}(i + 2) \quad (10)$$

Where i denotes the i-th signal point

The detection of R wave is obtained if a point of the derivative exceeds a threshold $S1=0.7$ proportional to the maximum amplitude of the derived signal.

Finally, Ahlstrom and Tompkins in [4] to detect the R peaks were based on the exploitation of the first and second derivative of the ECG signal. First, the absolute value of the derivative is calculated, then smoothed using (11). In the next step, the summation of the absolute value of the smoothed first derivative and the absolute value of the second derivative is realized.

Two thresholds ($S1 = 0.8 * \text{max amplitude of the sum signal}$ and $S2 = 0.1 * \text{max amplitude of the sum signal}$) are used. Then, we search for a point above the first threshold S1, and there is R peak detection if the following six points reach or exceed the second threshold S2.

$$\text{Smoothed Signal}(i) = [\text{signal}(i - 1) + 2 * \text{signal}(i) + \text{signal}(i + 1)]/4 \quad (11)$$

Where i denotes the i-th signal point

2. Method Based On DyWT

For a proper detection of the R peaks, and an exact location of this wave, we propose using the DyWT.

As input, we have the QRS complex whose frequencies vary between 5 and 15 Hz. Thus, by applying the same process (III.A.2), we obtain a scale factor of order 4.

Based on this important parameter, we have designed our detection and localization algorithm of the R wave by using a Db4 mother wavelet, which is characterized by the strong resemblance of its model to the ECG signal.

After calculating the DyWT of the ECG signal in the scale 2^4 ($j = 4$) by (2), we use the time windowing technique. For our algorithm, we set the time of window at 4s. Then, for each window, we locate the positive maxima and the negative minima of the DyWT by report respectively in thresholds S1 and S2 where the S1 and S2 thresholds are chosen as $0.45 * \text{max signal amplitude}$ and $0.28 * \text{min signal amplitude}$. When we have all the possible QRS, it is necessary to remove the redundant minima and maxima and the isolated couples. The principle is to eliminate among two minima (or maxima), the minimum (or maximum) farthest from the maxima (or minima) of the couple, to have at the end only the closest couples of the negative minima- positive maxima and which are the most likely to be the Wavelet Transform of the QRS complex. Finally, we locate the R peaks of QRS complexes from different intervals limited by the negative minima-positive maxima couples by looking for the points in which the DyWT vanishes.

IV. RESULTS AND DISCUSSIONS

The developed methods are applied to nine recordings in the database MIT-BIH of 10 minutes duration. These recordings show different types of noises to better illustrate the effectiveness of detection algorithms to pinpoint R peaks.

A. Pretreatment of ECG Signal

For the DyWT method and to purify the noisy ECG signals, we use a filtering by the Daubechies wavelet (Fig. 3 (b)).

For the derived calculation methods, two digital filters are put in competition. The first is the band-pass filter $H_1(z)$ in cascade with $H_2(z)$ (Fig. 3 (c)), the second is the band-pass filter $H_1(z)$ in cascaded with $H_3(z)$ (Fig. 3 (d)).

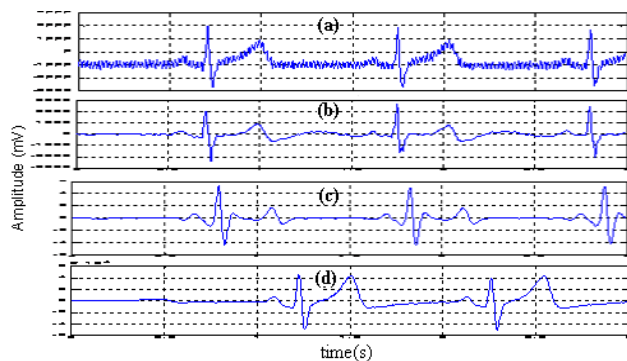

Fig. 3 Sample of ECG signal: (a) initial, (b) filtered by Db filter, (c) filtered by $H_1.H_2$, (d) filtered by $H_1.H_3$

According to Fig. 3, we note that by using the filter $H_1(z)$ $H_3(z)$ we have a good noise filtering, but an attenuation of the amplitudes of the R wave and a side effect appears clearly for the initial values. The filter $H_1(z)$ $H_2(z)$ properly purifies

a high frequency noise and retains the amplitudes of low frequencies waves, but, it generates a small shift, to the order of 10^{-1} , of the location of R peaks. Thus, for the methods based on derived calculations, we adopt the last filter.

B. Detection of R Peaks

In the present work, we study the different methods involved in detecting R peaks. We will evaluate the results basing on two criteria: the first one being the rate of Non Detection (ND) which is the number of labeled R peaks that are not detected. The second being the False detection rate (FD) recorded in the absence of a R peak. The Table below reports the results of detection of each method: Hoslinger (H.), Fraden and Neuman (F. and N), Menard (M.), Ahlstrom and Tompkins (A. and T.) and DyWT based on Db4.

According to Table II, it turned out that the derived methods studied have thresholding problems. In fact, we find that some results are not significant. The methods of Ahlstrom and Tompkins, Menard and Fraden and Newman have a high rate of non detection and especially false detections, particularly for highly noisy signals. In reality, the non detections generated by these methods are explained by the sensitivity to noise and therefore the threshold, and false detections obtained by these algorithms are due to noise sensitivity and the large amplitude waves T. Therefore, these techniques suffer from two major problems. The first is that the bandwidth of the QRS complex differs from one individual to another, and even in the same subject from one cycle to another. The second difficulty is the choice of a decision threshold. The threshold is usually empirically determined, additional conditions must be considered before the final decision.

We notice from Table II that the results of detection by the DyWT method are very satisfactory, since the rate of total error detection is equal to 0.74%. So, our detection algorithm based on Wavelet Transforms achieves a percentage of detecting R waves of the QRS complexes equal to 99.26%. This is despite the existence of different types of waves and noises in the recordings which can distort the detection. Moreover, the method of DyWT is very efficient in terms of positional accuracy of the R peaks; we do this by locating a minimum threshold for a negative and positive threshold for the maximum, so we detect the true QRS complexes and not other waves. However, the method of Hoslinger, which despite an average detection rate that is very high equal to 98, 9%, allows an inaccurate location of the peaks R.

TABLE II
RESULTS OF THE R PEAKS DETECTION BY THE PROPOSED ALGORITHMS

Record (present R peaks)		1(467)	2(556)	3(649)	4(651)	5(558)	6(577)	7(511)	8(350)	9(550)
Method										
H.	R detected	467	558	655	651	561	585	512	339	551
	F D	1	2	9	0	4	8	1	1	5
	N D	1	0	3	0	1	0	0	12	4
	%Error	0.43%	0.36%	1.85%	0%	0.9%	1.39%	0.19%	2.89%	1.63%
F.	R detected	463	561	630	645	543	570	514	333	545
and	F D	3	8	10	0	1	0	11	1	2
N	N D	7	3	29	6	16	7	8	18	7
	%Error	2.14%	1.98%	6.01%	0.92%	3.05%	1.21%	3.71%	4.22%	1.64%
M.	R detected	462	554	610	622	545	573	507	340	549
	F D	4	0	0	1	0	0	0	0	0
	N D	9	3	39	30	13	4	4	10	1
	%Error	2.78%	0.54%	6.01%	4.76%	2.33%	0.69%	0.78%	2.22%	0.18%
A.	R detected	465	557	620	630	549	577	510	342	548
and	F D	0	1	0	1	1	1	0	2	0
T	N D	2	0	29	22	10	1	1	10	2
	%Error	0.43%	0.18%	4.47%	3.53%	1.97%	0.53%	0.19%	2.67%	0.36%
DB4	R detected	467	555	646	645	553	573	344	344	549
	F D	0	0	1	0	1	0	0	0	0
	N D	0	1	4	6	6	4	6	6	1
	%Error	0%	0.18%	0.77%	0.92%	1.25%	0.69%	1.33%	1.33%	0.18%

V. CONCLUSION

The characterization of normal and abnormal parameters of the various morphologies of the cardiac signal is very interesting for the detection of multiple anomalies. The use of methods to detect R peaks appears very promising for such a characterization.

Starting with the filtering algorithms of the ECG, we performed a filter to eliminate low frequency deviations from the baseline by two techniques, one based on a low frequencies digital filter, the second based on the coefficients of the DWT and zeroing of the approximation coefficients which are responsible for the movements of the baseline. Then we propose a noise filtering of rapid changes in the ECG signal not only by digital filtering of the high frequencies, but also by thresholding the coefficients of the detail. To continue of this work, we develop algorithms for the localization of the R wave of the ECG signal by applying four derived calculation methods and DyWT method which gives the case of QRS a couple negative minimum-positive maximum setting, and an interval in which we have investigated the R waves.

The results obtained show that the R wave of ECG can be estimated with a good accuracy for the DyWT method. However, the used derived methods, particularly Ahlstrom and Tompkins, Menard and Fraden and Newman, appear sensitive to threshold and noise.

REFERENCES

[1] A. Menrad. "Dual microprocessor system for cardiovascular data acquisition, processing and recording," in Proc. 1981 IEEE Int. Conf. Industrial Elect. Contr. Instrument., 1981, pp. 64-69.

[2] P. Holsinger, K.M. Kempner and M.H. Miller, "A QRS preprocessor based on digital differentiation," IEEE Trans. Biomed. Eng., vol. 18, pp. 121-127, May 1971.

[3] J. Fraden and M. R. Neuman. "QRS wave detection". Med. & Biol. Eng. & Comp. vol. 18, pp. 125-132, Mar. 1980.

[4] M.L. Ahlstrom and W.J. Tompkins. "Automated high-speed analysis of holter tapes with microcomputers," IEEE Trans. Biomed. Eng., vol. 30, pp. 651-657, Oct. 1983.

[5] Q. Xue, Y.H. Hu and W.J. Tompkins. "Neural-Network-based Adaptive Matched Filtering for QRS detection," IEEE Trans. Biomed. Eng., vol. 39, pp. 317-329, 1992.

[6] S. Sumathi and Dr.M.Y. Sanavullah. "Comparative Study of QRS Complex Detection in ECG Based on Discrete Wavelet". International Journal of Recent Trends in Engineering, Vol 2, No. 5, pp. 273-277, 2009.

[7] C. Li and C. Zheng. "QRS Detection by Wavelet Transform," in Proc. 15th Ann. Int. Conf. IEEE Eng. Med. Biol. Soc., 1993, pp. 330-331.

[8] R. Gautam and A. Sharmar. "Detection of QRS complexes of ECG recording based on Wavelet Transform using MATLAB". International Journal of Engineering Science and Technology, vol. 2(7), pp. 3038-3044, 2010.

[9] A.R. Al Qawasmī and K. Daqrouq. "ECG Signal Enhancement Using Wavelet Transform," WSEAS Trans on Biology and Biomedicine, vol. 7, Issue 2, pp. 62-72, Apr. 2010.

[10] G.M. Friesen, T.C. Jannett, M.A. Jadallah, S.L. Yates and H.t. Nagle. "A Comparison of the Noise Sensitivity of Nine QRS Detection Algorithms," IEEE Trans. Biomed. Eng., vol. 37, No. 1, pp. 85-98, 1990.

[11] T.Y.Lo and P.C.Tang, "A fast bandpass filter for ECG processing", Proc. IEEE Eng. Med. Biol. Soc. 4th Annu. Int. Conf, 1982.

[12] M. Kania, M. Fereniec and R. Maniewski. "Wavelet Denoising for Multi-lead High Resolution ECG Signals". Measurement science review, vol. 7, Section 2, No. 4, pp. 30-33, 2007.

[13] P. S Gokhale. "ECG Signal De-noising using Discrete Wavelet Transform for removal of 50Hz PLI noise". International Journal of Emerging Technology and Advanced Engineering, Vol. 2, Issue 5, pp. 81-85, May 2012.

[14] Z. Germán-Salló, "Wavelet Transform Based ECG Signal Denoising", presented at the Scientific International Conference Interdisciplinarity in Engineering, Mures, Romania, 2007.