

Capacitor Placement in Radial Distribution System for Loss Reduction Using Artificial Bee Colony Algorithm

R. Srinivasa Rao

Abstract—This paper presents a new method which applies an artificial bee colony algorithm (ABC) for capacitor placement in distribution systems with an objective of improving the voltage profile and reduction of power loss. The ABC algorithm is a new population based meta heuristic approach inspired by intelligent foraging behavior of honeybee swarm. The advantage of ABC algorithm is that it does not require external parameters such as cross over rate and mutation rate as in case of genetic algorithm and differential evolution and it is hard to determine these parameters in prior. The other advantage is that the global search ability in the algorithm is implemented by introducing neighborhood source production mechanism which is a similar to mutation process. To demonstrate the validity of the proposed algorithm, computer simulations are carried out on 69-bus system and compared the results with the other approach available in the literature. The proposed method has outperformed the other methods in terms of the quality of solution and computational efficiency.

Keywords—Distribution system, Capacitor Placement, Loss reduction, Artificial Bee Colony Algorithm.

I. INTRODUCTION

THE power losses in distribution systems correspond to about 70% of total losses in electric power systems [1]. These losses can be considerably reduced through the installation and control of reactive support equipments, such as capacitor banks, reducing reactive currents in distribution feeders. Furthermore, voltage profiles, power-factor and feeder capability of distribution substations are also significantly improved. The placement of capacitor banks on distribution feeders involves determination of size, type (fixed or switched), location of capacitors at specified load levels. The main objective in capacitor placement problem is to minimize the total cost which is the amount of energy losses of whole system and investment and maintenance cost of installed capacitors while the voltage constraints of each node of the system hold within the limits.

Since, the optimal capacitor placement is a complicated combinatorial optimization problem, many different optimization techniques and algorithms have been proposed in the past. H. Ng et al [2] proposed the capacitor placement problem by using fuzzy approximate reasoning. Sundharajan and Pahwa [3] proposed the genetic algorithm approach to determine the optimal placement of capacitors based on the mechanism of natural selection. Ji-Pyng Chiou et al [4] proposed the variable scale hybrid differential evolution algorithm

for the capacitor placement in distribution system. Grainger et al [5]- [6] and Baghzouz and Ertem [7] proposed the concept that the size of capacitor banks was considered as a continuous variable. Bala et al [8] presented a sensitivity-based method to solve the optimal capacitor placement problem.

In this paper, a new algorithm called artificial bee colony (ABC) algorithm is proposed to place the capacitors at candidate locations with an objective of reducing the power losses in the distribution system. The artificial bee colony algorithm is a new meta heuristic approach, proposed by Karaboga [9]- [11]. It is inspired by the intelligent foraging behavior of honey bee swarm. The proposed method is tested on 14 and 33 bus radial distribution systems and results obtained are effective and encouraging.

II. PROBLEM FORMULATION

The objective of capacitor placement in the distribution system is to minimize the annual cost of the system, subjected to certain operating constraints and load pattern. For simplicity, the operation and maintenance cost of the capacitor placed in the distribution system is not taken into consideration. The three-phase system is considered as balanced and loads are assumed as time invariant.

Mathematically, the objective function of the problem is described as:

$$\text{Minimize } f = \text{Min. } (COST + \lambda \Delta V_{min}^2) \quad (1)$$

where $COST$ includes the cost of power loss and the capacitor placement, and will be discussed further later. λ is a penalty function and ΔV_{min}^2 is the squared sum of the violated voltage constraint. Moreover, the penalty function satisfies the following properties:

(1) if the voltage constraint is not violated, $\lambda = 0$;

(2) if the constraint is violated, a significant penalty is imposed to cause the objective function to move away from the undesirable solution.

The voltage magnitude at each bus must be maintained within its limits and is expressed as:

$$V_{min} \leq |V_k| \leq V_{max} \quad (2)$$

where $|V_k|$ is the voltage magnitude of bus k , V_{min} and V_{max} are minimum and maximum permissible voltages limits, respectively.

Dr. R. Srinivasa Rao is with the Department of Electrical and Electronics Engineering, J. N. T. University Kakinada, INDIA, e-mail: kau5@in.com.

The power loss of any line section connecting buses k and $k+1$ can be computed as

$$P_{Loss}(k, k+1) = R_{k,k+1} \frac{(P_k^2 + Q_k^2)}{|V_k|^2} \quad (3)$$

The total power loss in all feeders, $P_{T, Loss}$ may then be determined by summing up the losses of all line sections of the feeder, which is given as

$$P_{T, Loss} = \sum_{k=0}^{n-1} P_{Loss}(k, k+1) \quad (4)$$

Considering the practical capacitors, there exists a finite number of standard sizes which are integer multiples of the smallest size Q_0^C . Besides, the cost per kVAR varies from one size to another. In general, capacitors of larger size have lower unit prices. The available capacitor size is usually limited to

$$Q_{max}^C = L \cdot Q_0^C \quad (5)$$

where L is an integer multiplier. Therefore, for each installation location, there are L capacitor sizes $\{Q_0^C, 2Q_0^C, 3Q_0^C, \dots, LQ_0^C\}$ available. Given the annual installation cost for each compensated bus, the total cost due to capacitor placement and power loss change is computed by the formula:

$$COST = K_P P_{T, Loss} + \sum_{k=1}^n (K_{cf} + K_k^C Q_k^C) \quad (6)$$

where n is number of candidate locations for capacitor placement, K_P is the equivalent annual cost per unit of power loss in Rs/(kW-year); K_{cf} is the fixed cost for the capacitor placement. The constant K_k^C is the annual capacitor installation cost, and, $k = 1, 2, \dots, n$ are the indices of the buses selected for compensation. The bus reactive compensation power is limited to

$$Q_k^C \leq \sum_{k=1}^n Q_{Lk} \quad (7)$$

where Q_k^C and Q_{Lk} are the capacitive and inductive reactive powers at bus k respectively.

III. OVERVIEW OF ARTIFICIAL BEE COLONY ALGORITHM (ABC)

In the ABC algorithm, the colony of artificial bees contains three groups of bees: employed bees, onlookers and scouts. A bee waiting on the dance area for making decision to choose a food source is called an onlooker and a bee going to the food source visited by it previously is named an employed bee. A bee carrying out random search is called a scout. In the ABC algorithm, first half of the colony consists of employed artificial bees and the second half constitutes the onlookers. For every food source, there is only one employed bee. In other words, the number of employed bees is equal to the number of food sources around the hive. The employed bee whose food source is exhausted by the employed and onlooker bees becomes a scout. In the ABC algorithm, each cycle of the search consists of three steps: sending the employed bees onto the food sources and then measuring their nectar

amounts; selecting of the food sources by the onlookers after sharing the information of employed bees and determining the nectar amount of the foods; determining the scout bees and then sending them onto possible food sources. At the initialization stage, a set of food source positions are randomly selected by the bees and their nectar amounts are determined. Then, these bees come into the hive and share the nectar information of the sources with the bees waiting on the dance area within the hive. At the second stage, after sharing the information, every employed bee goes to the food source area visited by her at the previous cycle since that food source exists in her memory, and then chooses a new food source by means of visual information in the neighborhood of the present one. At the third stage, an onlooker prefers a food source area depending on the nectar information distributed by the employed bees on the dance area. As the nectar amount of a food source increases, the probability with which that food source is chosen by an onlooker increases, too. Hence, the dance of employed bees carrying higher nectar recruits the onlookers for the food source areas with higher nectar amount. After arriving at the selected area, she chooses a new food source in the neighborhood of the one in the memory depending on visual information. Visual information is based on the comparison of food source positions. When the nectar of a food source is abandoned by the bees, a new food source is randomly determined by a scout bee and replaced with the abandoned one. In our model, at each cycle at most one scout goes outside for searching a new food source and the number of employed and onlooker bees were equal.

The probability P_i of selecting a food source i is determined using the following expression:

$$P_i = \frac{fit_i}{\sum_{n=1}^{S_N} fit_n} \quad (8)$$

where fit_i is the fitness of the solution represented by the food source i and S_N is the total number of food sources. Clearly, with this scheme good food sources will get more onlookers than the bad ones. After all onlookers have selected their food sources, each of them determines a food source in the neighborhood of his chosen food source and computes its fitness. The best food source among all the neighboring food sources determined by the onlookers associated with a particular food source i and food source i itself, will be the new location of the food source i . If a solution represented by a particular food source does not improve for a predetermined number of iterations then that food source is abandoned by its associated employed bee and it becomes a scout, i.e., it will search for a new food source randomly. This tantamount to assigning a randomly generated food source (solution) to this scout and changing its status again from scout to employed. After the new location of each food source is determined, another iteration of ABC algorithm begins. The whole process is repeated again and again till the termination condition is satisfied.

The food source in the neighborhood of a particular food source is determined by altering the value of one randomly chosen solution parameter and keeping other parameters unchanged. This is done by adding to the current value of the

chosen parameter the product of a uniform variate in $[-1, 1]$ and the difference in values of this parameter for this food source and some other randomly chosen food source.

Formally, suppose each solution consists of d parameters and let $x_i = (x_{i1}, x_{i2}, \dots, x_{id})$ be a solution with parameter values $x_{i1}, x_{i2}, \dots, x_{id}$. In order to determine a solution v_i in the neighborhood of x_i , a solution parameter j and another solution $x_k = (x_{k1}, x_{k2}, \dots, x_{kd})$ are selected randomly. Except for the value of the selected parameter j , all other parameter values of v_i are same as x_i i.e., $v_i = (x_{i1}, x_{i2}, \dots, x_{i(j-1)}, x_{ij}, x_{i(j+1)}, \dots, x_{id})$. The value v_i of the selected parameter j in v_i is determined using the following formula:

$$v_{ij} = x_{ij} + u(x_{ij} - x_{kj}) \quad (9)$$

where u is an uniform variate in $[-1, 1]$. If the resulting value falls outside the acceptable range for parameter j , it is set to the corresponding extreme value in that range.

The proposed artificial bee colony algorithm is summarized as follows:

1. Read input data and Initialize MNC;
2. Initialize the population, $x_{ij} = (Q_{i1}, Q_{i2}, \dots, Q_{ij})$;
3. Evaluate fitness value for each employed bee by using the following the formula

$$fitness = \frac{1}{1 + Power\ loss}$$

4. Initialize cycle=1;
5. Generate new population (solution) v_{ij} in the neighborhood of x_{ij} for employed bees using equation 9 and evaluate them;
6. Apply the greedy selection process between x_i and v_i ;
7. Calculate the probability values P_i for the solutions x_i by means of their fitness values using the equation 8;
8. Produce the new populations v_i for the onlookers from the populations x_i , selected based on P_i by applying roulette wheel selection process, and evaluate them;
9. Apply the greedy selection process for the onlookers between x_i and v_i ;
10. Determine the abandoned solution, if exists, and replace it with a new randomly produced solution x_i for the scout bees using the following equation: $x_{ij} = min_j + rand(0, 1) * (max_j - min_j)$;
11. Memorize the best solution achieved so far;
12. cycle=cycle+1;
13. if cycle<MIC, go to step 5, otherwise go to step 14;
14. Stop.

IV. TEST RESULTS

The proposed method was tested on 69-bus radial distribution system and results have been obtained to evaluate its effectiveness. The algorithm of this method was programmed in MATLAB environment and run on a Pentium IV, 3-GHz personal computer with 0.99 GB RAM.

69 - bus system: To test the proposed method, a 69-node radial distribution system shown in Fig. 1 has been taken as an example network [12]. Line data and nominal load data for this system are given in Appendix A.

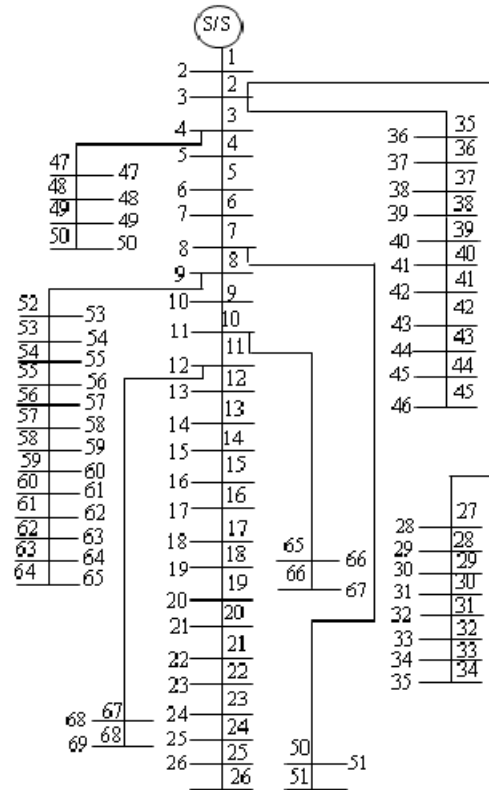

Fig. 1. 69-bus radial distribution system

For this test feeder, K_P is selected to be 168 \$/(kW-year) [7]. Only fixed capacitors are used in the analysis and the marginal cost of capacitors given [14] are used to compute the total annual cost. The fixed cost of the capacitor, K_{cf} is selected as \$1000 [15] with a life expectancy of ten years (the maintenance and running costs are neglected). The substation voltage (bus 1) is considered as 1.0 p.u. The limit of voltage magnitude is taken between 0.90 to 1.10 p.u.

Using sensitivity analysis the buses are ordered according to their sensitivity value ($\partial P_{Linloss} / \partial Q_{eff}$) (i.e. nodes 61, 64, 59, 65, ...). Top three nodes are selected as candidate locations (i.e. nodes 61, 64 and 59) to reduce the search space and then the amount to be injected in the selected nodes is optimized by ABC. Using this method, the capacitors of rating 700, 800, 100 kVAR are placed at the optimal candidate locations 61, 64, and 59, respectively. The simulation results are shown in I. Table I also shows the comparison of results Particle Swarm Optimization (PSO) [13]. The minimum voltage before capacitor installation is 0.90919 p.u (bus 65) and is raised to 0.93693 p.u (bus 65) after capacitor installation.

From Table I, it is observed that the power loss obtained with the proposed method is approximately 10 kW less than

TABLE I
COMPARISON OF SIMULATION RESULTS OF 69-BUS SYSTEM

item	Uncompe-nsated	Compensated	
		PSO [13]	Proposed
Total losses (kW)	224.96	1566.62	146.75
Loss reduction (%)	—	31.39	34.76
Optimal locations and Size in kVAR	—	46 241	61 600
		47 365	64 700
		50 1015	59 100
Total kVAR		1621	1400
Annual Cost (\$/year)	37793.28	29578.32	27830.55
Net Savings (\$/year)	—	8216.26	9962.73
% Saving	—	21.74	26.36

that of (PSO) [13]. The optimal candidate locations are the same with all methods but the total kVAR injected by the proposed method is less by 200 kVAR than that of PSO method. The net saving in the cost by the proposed method is 5% less than that of the PSO method.

V. CONCLUSION

In the present work, a new population based artificial bee colony algorithm (ABC) has been proposed to solve capacitor placement problem in distribution system. Simulations are carried on 69-bus systems and results are compared with the other population based method PSO. The results obtained by the proposed method out perform the other methods in terms of quality of the solution and computation efficiency.

The main advantage of ABC algorithm is that it does not require external parameters such as cross over rate and mutation rate etc, as in case of genetic algorithms, differential evolution and other evolutionary algorithms and these are hard to determine in prior. The other advantage is that the global search ability in the algorithm is implemented by introducing neighborhood source production mechanism which is a similar to mutation process.

APPENDIX A

LINE AND LOAD DATA OF 69-BUS SYSTEM

Br. No. (i)	Send. end IS(i)	Recv. end IR(i)	R (Ω)	X (Ω)	P_L (kW)	Q_L (kW)
1	1	2	0.0005	0.0012	0	0
2	2	3	0.0005	0.0012	0	0
3	3	4	0.0015	0.0036	0	0
4	4	5	0.0251	0.0294	0	0
5	5	6	0.366	0.1864	2.6	2.2
6	6	7	0.3811	0.1941	40.4	30
7	7	8	0.0922	0.047	75	54
8	8	9	0.0493	0.0251	30	22
9	9	10	0.819	0.2707	28	19
10	10	11	0.1872	0.0619	145	104
11	11	12	0.7114	0.2351	145	104
12	12	13	1.03	0.34	8	5

Br. No. (i)	Send. end IS(i)	Recv. end IR(i)	R (Ω)	X (Ω)	P_L (kW)	Q_L (kW)
13	13	14	1.044	0.345	8	5.5
14	14	15	1.058	0.3496	0	0
15	15	16	0.1966	0.065	45.5	30
16	16	17	0.3744	0.1238	60	35
17	17	18	0.0047	0.0016	60	35
18	18	19	0.3276	0.1083	0	0
19	19	20	0.2106	0.069	1	0.6
20	20	21	0.3416	0.1129	114	81
21	21	22	0.014	0.0046	5	3.5
22	22	23	0.1591	0.0526	0	0
23	23	24	0.3463	0.1145	28	20
24	24	25	0.7488	0.2475	0	0
25	25	26	0.3089	0.1021	14	10
26	26	27	0.1732	0.0572	14	10
27	3	28	0.0044	0.0108	26	18.6
28	28	29	0.064	0.1565	26	18.6
29	29	30	0.3978	0.1315	0	0
30	30	31	0.0702	0.0232	0	0
31	31	32	0.351	0.116	0	0
32	32	33	0.839	0.2816	14	10
33	33	34	1.708	0.5646	19.5	14
34	34	35	1.474	0.4873	6	4
35	3	36	0.0044	0.0108	26	18.55
36	36	37	0.064	0.1565	26	18.55
37	37	38	0.1053	0.123	0	0
38	38	39	0.0304	0.0355	24	17
39	39	40	0.0018	0.0021	24	17
40	40	41	0.7283	0.8509	1.2	1
41	41	42	0.31	0.3623	0	0
42	42	43	0.041	0.0478	6	4.3
43	43	44	0.0092	0.0116	0	0
44	44	45	0.1089	0.1373	39.22	26.3
45	45	46	0.0009	0.0012	39.22	26.3
46	4	47	0.0034	0.0084	0	0
47	47	48	0.0851	0.2083	79	56.4
48	48	49	0.2898	0.7091	384.7	274.5
49	49	50	0.0822	0.2011	384.7	274.5
50	8	51	0.0928	0.0473	40.5	28.3
51	51	52	0.3319	0.1114	3.6	2.7
52	9	53	0.174	0.0886	4.35	3.5
53	53	54	0.203	0.1034	26.4	19
54	54	55	0.2842	0.1447	24.4	17.2
55	55	56	0.2813	0.1433	0	0
56	56	57	1.5900	0.5337	0	0
57	57	58	0.7837	0.263	0	0
58	58	59	0.3042	0.1006	100	72
59	59	60	0.3861	0.1172	0	0
60	60	61	0.5075	0.2585	1244	888
61	61	62	0.0974	0.0496	32	23
62	62	63	0.145	0.0738	0	0
63	63	64	0.7105	0.3619	227	162
64	64	65	1.041	0.5302	59	42
65	11	66	0.2012	0.0611	18	13
66	66	67	0.0047	0.0014	18	13
67	12	68	0.7394	0.2444	28	20
68	68	69	0.0047	0.0016	28	20

ACKNOWLEDGMENT

The author would like to thank Jawaharlal Nehru Technological University Kakinada for providing the infrastructure to complete this work.

REFERENCES

- [1] C. Lyra, C. Pissara, C. Cavellucci, A. Mendes, P. M. Franca, "Capacitor placement in largesized radial distribution networks, replacement and sizing of capacitor banks in distorted distribution networks by genetic algorithms", *IEE Proceedings Generation, Transmision & Distribution*, pp. 498-516, 2005.
- [2] Ng H.N., Salama M.M.A. and Chikhani A.Y, "Capacitor allocation by approximate reasoning: fuzzy capacitor placement", *IEEE Transactions on Power Delivery*, vol. 15, No. 1, pp. 393-398, 2000.
- [3] Sundharajan and A. Pahwa, "Optimal selection of capacitors for radial distribution systems using genetic algorithm", *IEEE Trans. Power Systems*, vol. 9, No.3, pp.1499-1507, Aug. 1994.
- [4] Ji-Pyng Chiou et al, "Capacitor placement in large scale distribution system using variable scaling hybrid differential evolution", *Electric Power and Energy Systems*, vol. 28, pp.739-745, 2006.
- [5] J. J. Grainger, S. H. Lee, "Optimum size and location of shunt capacitors for reduction of losses on distribution feeders", *IEEE Trans Power Apparatus Systems*, vol. 100, pp. 1105-1108, 1981.
- [6] S. H. Lee, J. J. Grainger, "Optimum placement of fixed and switched capacitors on primary distribution feeders", *IEEE Trans PAS*, vol. 100, pp. 345-352, 1981.
- [7] Baghzouz. Y and Ertem S, "Shunt capacitor sizing for radial distribution feeders with distorted substation voltages", *IEEE Trans Power Delivery*, vol. 5, pp.650-57, 1990.
- [8] J. L. Bala, P. A. Kuntz, M. Taylor, "Sensitivity-based optimal capacitor placement on a radial distribution feeder", Proc. Northcon 95, *IEEE Technical Application Conf.*, pp. 225230, 1995.
- [9] B. Basturk, D. Karaboga, "An artificial bee colony (ABC) algorithm for numeric function optimization", *IEEE Swarm Intelligence Symposium 2006*, May 12-14, Indianapolis, IN, USA, 2006.
- [10] D. Karaboga, B. Basturk, "A powerful and efficient algorithm for numerical function optimization: artificial bee colony (ABC) algorithm", *Journal of Global Optimization*, vol. 39, pp. 459-471, 2007.
- [11] D. Karaboga, B. Basturk, "On the performance of artificial bee colony (ABC) algorithm", *Applied Soft Computing*, vol. 8 pp. 687-697, 2008.
- [12] Baran ME, Wu FF, "Optimal sizing of capacitors placed on a radial distribution systems", *IEEE Trans Power Deliver*, vol. 4, pp. 735-43, Jan. 1989.
- [13] Prakash K. and Sydulu M, "Particle swarm optimization based capacitor placement on radial distribution systems", *IEEE Power Engineering Society general meeting 2007*, pp. 1-5, 2007.
- [14] S. F. Mekhamer et al, "New heuristic strategies for reactive power compensation of radial distribution feeders", *IEEE Trans Power Delivery*, vol. 17, No. 4, pp.1128-1135, Oct. 2002.
- [15] D. Das, "Reactive power compensation for radial distribution networks using genetic algorithms", *Electric Power and Energy Systems*, vol. 24, pp.573-581, 2002.

BIOGRAPHY

Dr. R. Srinivasa Rao received the B.Tech degree in electrical engineering from SVU Tirupathi (INDIA) in 1996, the M.E degree from IISc Bangalore in 1998, and the Ph.D. degree from JNTU in 2009. Currently, he is Associate Professor in department of electrical engineering, JNTU Kakinada, INDIA. His areas of interest include electric power distribution systems and power systems operation and control.