

Automatic Generation Control Design Based on Full State Vector Feedback for a Multi-Area Energy System Connected via Parallel AC/DC Lines

Gulshan Sharma

Abstract—This article presents the design of optimal automatic generation control (AGC) based on full state feedback control for a multi-area interconnected power system. An extra high voltage AC transmission line in parallel with a high voltage DC link is considered as an area interconnection between the areas. The optimal AGC are designed and implemented in the wake of 1% load perturbation in one of the areas and the system dynamic response plots for various system states are obtained to investigate the system dynamic performance. The pattern of closed-loop eigenvalues are also determined to analyze the system stability. From the investigations carried out in the work, it is revealed that the dynamic performance of the system under consideration has an appreciable improvement when a high voltage DC line is paralleled with an extra high voltage AC line as an interconnection between the areas. The investigation of closed-loop eigenvalues reveals that the system stability is ensured in all case studies carried out with the designed optimal AGC.

Keywords—Automatic generation control, area control error, DC link, optimal AGC regulator, closed-loop eigenvalues.

I. INTRODUCTION

THE structure of power systems is getting large and complex day by day as demand of electrical power is increasing enormously throughout the world. The plants with increased capacity and bigger units are indispensable to meet the current power requirements. This has become important to meet the several economic and technical objectives set up by the various utilities. Due to economic reasons, these generating stations are situated at remote locations from the load centers. Every electrical utility is under obligation to provide a certain degree of continuity of power supply within a reasonable offset in frequency and voltage of the system to its consumers. Further, power supply to the consumers should be economical and profitable to the utilities. Moreover, realizing the benefits of variability in generation mixes and load patterns, utilities have switched over to operate in interconnected fashion with tie-lines over which the power is exchanged between the load centers and consumers, which ensures the overall reliability and economy. Therefore, the selection of transmission system plays an important role in the modern power systems. These lines should be capable of exchanging the electrical power among widely spread power pools in an efficient and effective manner. In earlier days, the power is transmitted from generating house to several load

centers by AC transmission lines operating at higher voltage levels, i.e., extra high voltage AC (EHVAC) lines. However, these transmission lines were associated with higher fault levels, oscillations were sensed in another control areas as well as the load disturbances are propagated to other control areas through AC tie-lines. All these problems were sought out with the emergence of DC transmission system which has numerous technical and economic advantages over AC lines. One of the most promising applications of HVDC transmission is its operation with AC link in parallel as an area interconnection between two areas. It has also demonstrated very effective in stabilizing the power system dynamics [1]-[3].

Normally, the power systems operate in nominal system state which is characterized by constant frequency and voltage profile of the system with certain specified system reliability. The frequency of modern energy system alters and attains a new value as the power necessity changes and hence affects the class electric energy deliverance to the clients. Hence, an effective control technique is always preferable for the electrical system so that at every instant, the electrical power generated must be balanced by the required load demand and the frequency deviations of energy system may vary within permissible ranges and does not affect the delivery of quality power to the customers.

The task of AGC is to adjust the output of synchronous generators within a defined boundary of control area as per the alterations in frequency and tie power and hence to keep the energy system operation well. Area control error (ACE) is the linear blend of shift in frequency and tie power. In literature, many research articles were reported concerning AGC of interconnected power systems [4]-[9]. Most of these studies were based on classical controllers approach. The gains of classical controllers were obtained through trial and error practice and the obtained control designs are unsuccessful for the diverse operating conditions of AGC of interconnected energy systems. The AGC controller design for an interconnected power system is a multivariable system problem and its effective control can be executed using modern control techniques. From the various research publications, it has been observed that the system's dynamic performance with greater stability margins can be achieved with optimal AGC regulators designed using optimal control strategies as compared to that obtained with conventional control techniques [10]-[18]. Therefore, the application of modern control theory is the most promising tool to handle the

Gulshan Sharma is with the Department of Electrical Engineering, Nirma University, Ahmedabad-382481, India (e-mail: gulshanmail2005@gmail.com).

AGC problem of large interconnected power systems. Further, the two-area power system models considered in most of these studies were consisting of identical non-reheat, reheat thermal turbines or hydro turbines. However, in real time operating situations, interconnected power systems are of multi-area type and consisting of various types of generations through turbines of diverse types. Therefore, these aspects need to be paid due attention while carrying out AGC studies of power systems.

In the present work, a multi-area interconnected power system with hydro turbines in area-1, non-reheat turbines in area-2 and tandem compound non-reheat turbines in area-3 is selected for the study. Two types of interconnections; (1) EHVAC transmission link and (2) parallel EHVAC/HVDC transmission links are considered between the different areas.

II. THE CONSIDERED SYSTEM MODELS

Model-1: It is a 3-area interconnected power system with hydro turbines in area-1, non-reheat turbines in area-2 and tandem compound non-reheat turbines in area-3. The three areas are interconnected via AC line only.

The model-2 is same as given above. However, control areas in multi-area are interconnected via parallel EHVAC/HVDC tie-lines. The transfer function model of the developed system is given in Fig. 1.

III. FULL STATE VECTOR FEEDBACK AGC DESIGN

The continuous time-invariant dynamic model of the system in the state variable form is given as [18]:

$$\frac{d}{dt}(X) = AX + BU + \Gamma P_d, \quad (1)$$

$$Y = CX \quad (2)$$

where X , U , Y and P_d represent the state, control, disturbance and output vector respectively and A = State, B =Control, C = Output and $n\Gamma$ =are the disturbance matrix.

The idea behind the control technique is to minimize the system index value defined as;

$$j = \int_0^{\infty} \frac{1}{2} [X^T QX + U^T RU] dt. \quad (3)$$

In the design of optimal AGC, (1) can be rewritten as:

$$\frac{d}{dt}(X) = AX + BU + \Gamma P_d, X(0) = X_0, \quad (4)$$

However, (2) will remain same. With a full state vector feedback control problem, a control law is stated in the form

$$U^* = -[\Psi^*] X, \quad (5)$$

which minimizes the cost function given by (3). For the

infinite time problem, the application of pontryagin's minimum principle results in the following matrix Riccati equation:

$$PA + A^T P - PBR^{-1}B^T P + Q = 0. \quad (6)$$

The solution of (6) yields a positive definite symmetric matrix, P , and the optimal control law is given by

$$U^* = -R^{-1}B^T P X. \quad (7)$$

The required optimal feedback gain matrix is given by

$$[\Psi^*] = R^{-1}B^T P. \quad (8)$$

IV. DYNAMIC SYSTEM MODEL

The power system models under consideration can be described in state variable form by (1) and (2). The structure various vectors are as:

Model-1

State vector:

$$X = \begin{bmatrix} \Delta F_1 \Delta F_2 \Delta F_3 \Delta P_{ie12} \Delta P_{ie23} \Delta P_{ie31} \Delta P_{M1} \Delta P_{M2} \Delta P_{x1} \Delta P_{x2} \\ \Delta P_{M3} \Delta x_{E1} \Delta x_{E2} \Delta x_{E3} \int ACE_1 dt \int ACE_2 dt \int ACE_3 dt \end{bmatrix}^T.$$

Control vector:

$$U = [\Delta P_{C1} \Delta P_{C2} \Delta P_{C3}]^T.$$

Disturbance vector:

$$P_d = [\Delta P_{D1} \Delta P_{D2} \Delta P_{D3}]^T.$$

Model-2

State vector:

$$X = \begin{bmatrix} \Delta F_1 \Delta F_2 \Delta F_3 \Delta P_{ie12} \Delta P_{ie23} \Delta P_{ie31} \Delta P_{M1} \Delta P_{M2} \Delta P_{x1} \Delta P_{x2} \Delta P_{M3} \\ \Delta x_{E1} \Delta x_{E2} \Delta x_{E3} \int ACE_1 dt \int ACE_2 dt \int ACE_3 dt \Delta P_{dc12} \Delta P_{dc23} \Delta P_{dc31} \end{bmatrix}^T.$$

Control vector:

$$U = [\Delta P_{C1} \Delta P_{C2} \Delta P_{C3}]^T.$$

Disturbance vector:

$$P_d = [\Delta P_{D1} \Delta P_{D2} \Delta P_{D3}]^T.$$

ACE_{m1}, ACE_{m2} and ACE_{m3} are the modified ACEs of areas 1, 2 and 3 respectively. The modified ACEs for area-1, area-2 and area-3 are derived herewith:

$$ACE_{m1} = B_1 \Delta F_1 + (\Delta P_{ie12} + a_{31} \Delta P_{ie31} + \Delta P_{dc12} + a_{31} \Delta P_{dc31}),$$

$$ACE_{m2} = B_2 \Delta F_2 + (\Delta P_{ie23} + a_{12} \Delta P_{ie12} + \Delta P_{dc23} + a_{12} \Delta P_{dc21}),$$

$$ACE_{m3} = B_3 \Delta F_3 + (\Delta P_{ie31} + a_{23} \Delta P_{ie23} + \Delta P_{dc31} + a_{23} \Delta P_{dc23}).$$

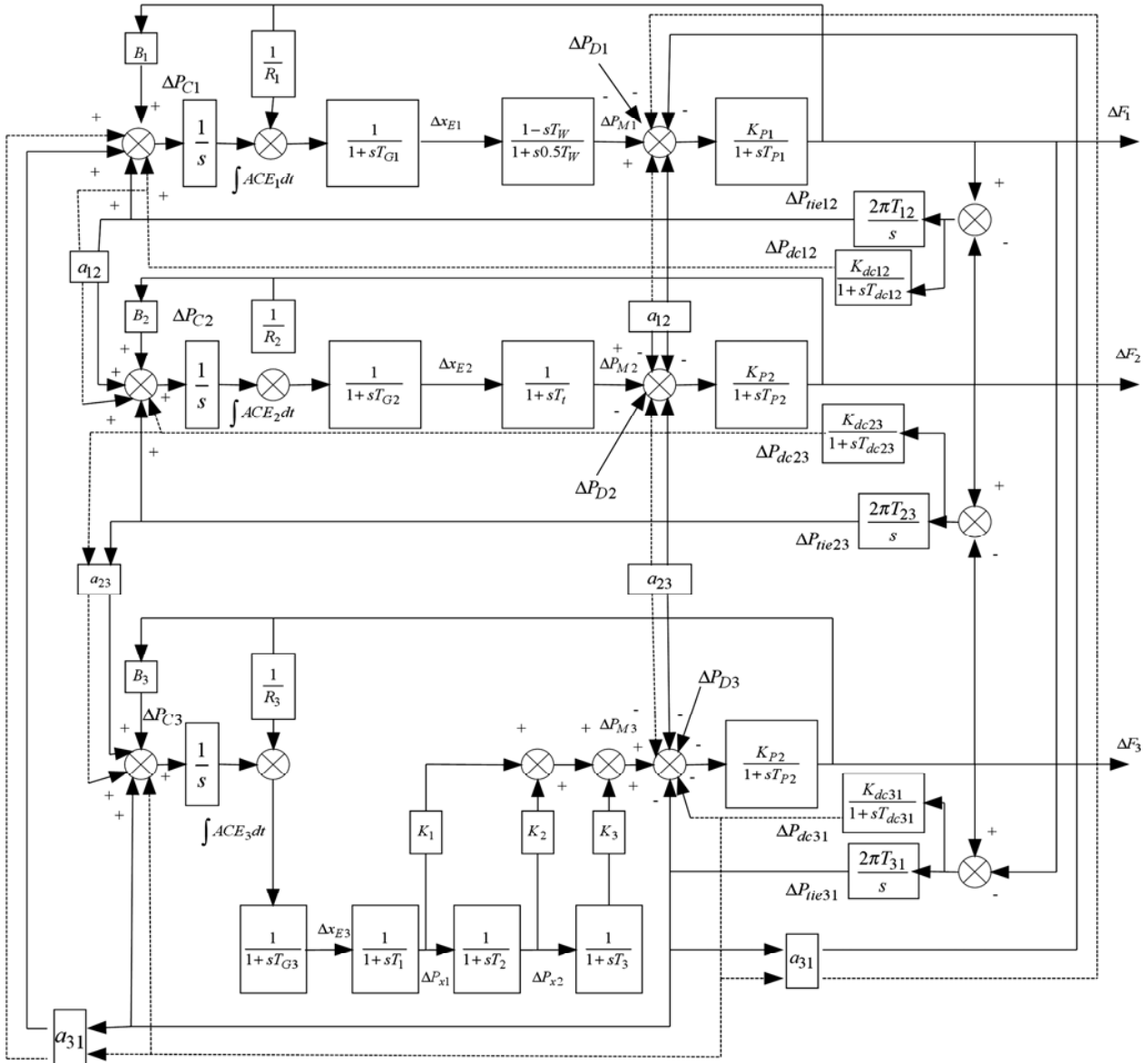

Fig. 1 Transfer function model of a multi-area interconnected electrical energy systems

V. ANALYSIS OF RESULTS

The optimal AGC are designed based on full state vector feedback control technique using performance index minimization. These performance index values are shown in Table I. The system state, control and disturbance matrices are derived from the transfer function model of the system as given in Fig. 1. The state cost weighting and control cost weighting matrices i.e. Q and R are selected of appropriate dimension for each system model under consideration. The closed-loop system eigenvalues are obtained to investigate the dynamic stability of the system with the implementation of designed AGC. The pattern of closed-loop system eigenvalues

are shown in Table II. The system dynamic response plots are plotted with the implementation of designed AGC considering 1% load disturbance in area-2. The response plots obtained are shown in Figs. 2-10.

Investigations of optimum performance index values reveal that there is an increase in optimum performance index value computed for system model-2 as compared to that obtained with model-1. The performance index values depend on the matrices Q and R. The lower performance index may result in deterioration in dynamic performance of the system. Thus, the proper choice of Q and R decides the value of minimum performance index as well as the cost of the physical realization of the controller. An investigation of closed-loop

system eigenvalues reveal that the all eigenvalues are associated with a negative real number to ensure system stability with considerable stability margins for both power system models. The incorporation of the HVDC link in parallel with the EHVAC link as a system interconnection has offered better system dynamic stability margins as compared to that offered when EHVAC link is considered as an area interconnection.

The investigation of the time response plots of Figs. 2-10 reveals that the proposed optimal AGC are successful in providing smooth settling of system dynamic responses for power system model-2 as compared to that obtained with power system model-1. Also, there is an appreciable reduction in the magnitude of the first peak of responses achieved with power system model-2 as compared to that obtained with power system model-1.

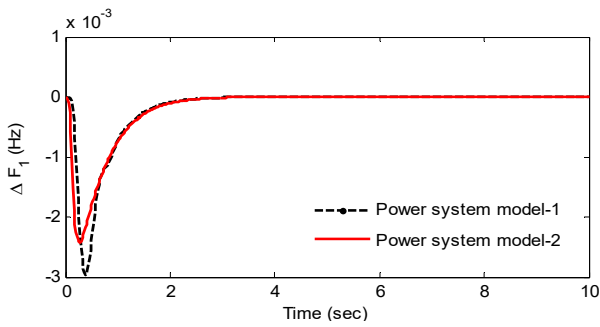

Fig. 2 Response of ΔF_1 for 1% load disturbance in area-2

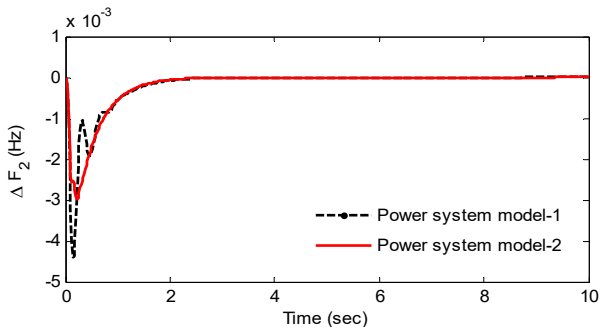

Fig. 3 Response of ΔF_2 for 1% load disturbance in area-2

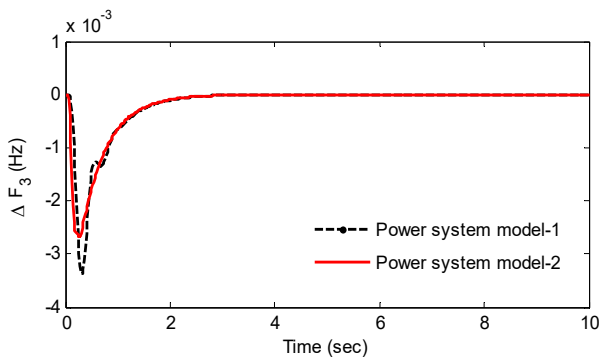

Fig. 4 Response of ΔF_3 for 1% load disturbance in area-2

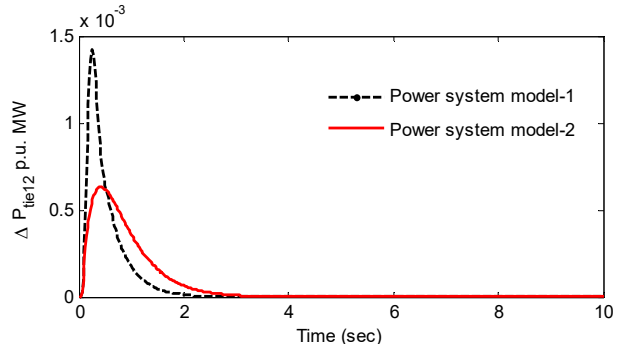

Fig. 5 Response of ΔP_{tie12} for 1% load disturbance in area-2

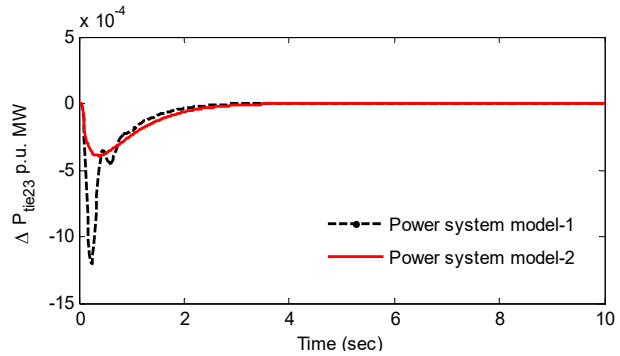

Fig. 6 Response of ΔP_{tie23} for 1% load disturbance in area-2

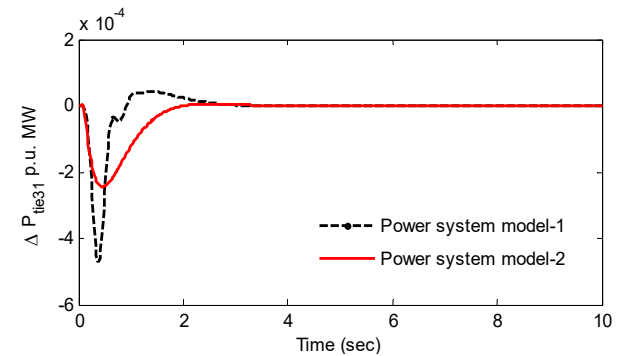

Fig. 7 Response of ΔP_{tie31} for 1% load disturbance in area-2

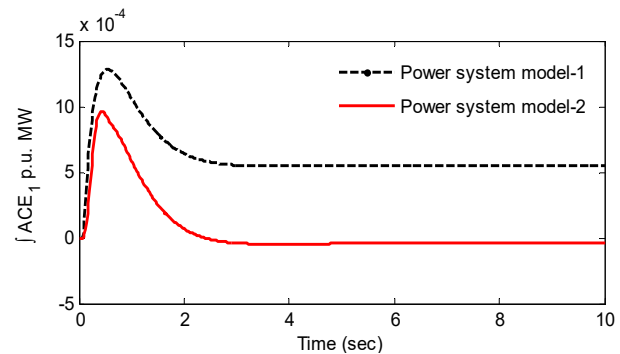

Fig. 8 Response of $\int ACE_1 dt$ for 1% load disturbance in area-2

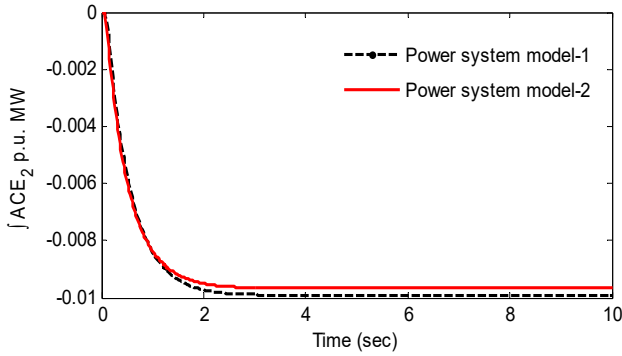

Fig. 9 Response of $\int ACE_2 dt$ for 1% load disturbance in area-2

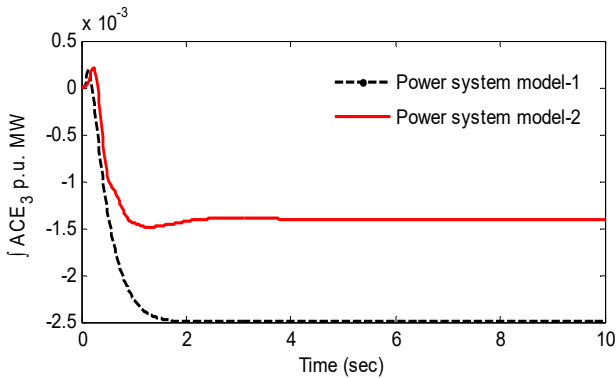

Fig. 10 Response of $\int ACE_3 dt$ for 1% load disturbance in area-2

TABLE I
COMPUTED PERFORMANCE INDEX

Type of Models	Computed Performance Index
Model-1	1.2474
Model-2	1.2738

TABLE II
THE SYSTEM EIGEN VALUES IN CLOSED-LOOP FASHION

Model-1	Model-2
-35.4777	-35.4410
-14.3541	-14.2322
-11.1816	-11.6577
-6.3109 + 1.4980i	-3.0231 + 9.8228i
-6.3109 - 1.4980i	-3.0231 - 9.8228i
-1.7503 + 3.3358i	-2.2250 + 9.7312i
-1.7503 - 3.3358i	-2.2250 - 9.7312i
-0.9824 + 3.0984i	-6.3743 + 1.6768i
-0.9824 - 3.0984i	-6.3743 - 1.6768i
-2.8353 + 1.3013i	-3.2866 + 1.4482i
-2.8353 - 1.3013i	-3.2866 - 1.4482i
-2.4287	-2.4803
-0.5435	-0.6615
-0.2854 + 0.1792i	-0.2941 + 0.1715i
-0.2854 - 0.1792i	-0.2941 - 0.1715i
-0.4063	-0.4942
-0.0000	-0.4060
	-0.4024
	-5.0000
	-0.0000

VI. CONCLUSIONS

The presents research work discusses the design of optimal AGC based on full state vector feedback control for a multi-area power system with diverse sources of energy in different power system areas of an interconnected electrical energy system. The designed optimal AGC are implemented and the dynamic performances for various system states are obtained considering 1% step load disturbance. From the investigations carried out, the following conclusions are drawn;

- The AGC design based on full state vector feedback provides promising system dynamic performance in a multi-area power system interconnected via EHVAC transmission line.
- Besides, the incorporation of HVDC line in parallel with EHVAC transmission link has improved the system dynamic stability margins of few states appreciably and also improved the dynamic performance of the power system to a great extent.
- The closed-loop system stability is ensured for all case studies. However, higher stability margins are achieved with model-2 as that achieved with model-1.
- Hence, the performance of AGC in a multi-area energy system improves a lot through installing an HVDC lines paralleled to AC lines.

APPENDIX

Numerical Date

$$P_{r1} = P_{r2} = P_{r3} = 2000 \text{ MW}, T_{G1} = 0.08 \text{ s}, T_{G2} = 0.1 \text{ s},$$

$$T_{G3} = 0.2 \text{ s}, R_1 = 2.5 \text{ Hz/p.u.MW}, R_2 = 2.5 \text{ Hz/p.u.MW},$$

$$R_3 = 2.6 \text{ Hz/p.u.MW}, T_w = 0.1 \text{ s}, T_T = 0.3 \text{ s}, T_1 = 0.2 \text{ s}, T_2 = 6 \text{ s},$$

$$T_3 = 0.4 \text{ s}, K_1 = 0.3, K_2 = 0.4, K_3 = 0.3,$$

$$B_1 = B_2 = B_3 = 0.425 \text{ p.u. MW/Hz},$$

$$\Delta P_{D1} = \Delta P_{D2} = \Delta P_{D3} = 0.01 \text{ p.u. MW}, H_1 = 0.06 \text{ s}, H_2 = 0.1 \text{ s},$$

$$H_3 = 0.16 \text{ s}, D_1 = D_2 = D_3 = 0.01 \text{ p.u. MW/Hz}.$$

Data for AC Link

$$P_{\max} = 200 \text{ MW}, T_{ij} = 0.545 \text{ p.u. MW/Hz}, \delta_1 - \delta_2 = 30^\circ.$$

Data for DC Link

$$K_{dc} = 1.0, T_{dc} = 0.2 \text{ s}.$$

REFERENCES

- [1] Sanpei, M., Kakehi, A., and Takeda, H., "Application of multi-variable control for automatic frequency controller of HVDC transmission system," *IEEE Trans. Power Delivery*, Vol. 9, No. 2, pp. 1063–1068, April 1994.
- [2] Kumar, P., and Ibraheem, "AGC strategies-a comprehensive review," *Int. J. Power Energy Syst.*, Vol. 16, No. 2, pp. 107–111, 1996.
- [3] Ibraheem, Kumar, P., and Khatoun, S., "Effects of parameters uncertainties of dynamics performance of an interconnected power system systems with AC/DC links," *Int. J. Power Energy Syst.*, Vol. 25, No. 3, pp. 196–210, 2005.
- [4] Elgerd, O. I., and Fosha, C., "Optimum megawatt frequency control of multi-area electric energy systems," *IEEE Trans. Power Appar. Syst.*, Vol. PAS-89, No. 4, pp. 556–563, April 1970.
- [5] Willems, J. L., "Sensitivity analysis of the optimum performance of conventional load frequency control," *IEEE Trans. Power Appar. Syst.*, Vol. PAS-93, No. 5, pp. 1287–1291, September/October 1974.

- [6] Nanda, J., and Kaul, B. L., "Automatic generation control of an interconnected power system," *Proc. IEE*, Vol. 125, No. 5, pp. 385–390, May 1978.
- [7] Kothari, M. L., Satsangi, P. S., and Nanda, J., "Sampled data automatic control of interconnected reheat thermal stations consisting generation rate constraints," *IEEE Trans. Power Appar. Syst.*, Vol. PAS-100, No. 5, pp. 2334–2342, May 1981.
- [8] Hiyama, T., "Optimization of discrete-type load-frequency regulators considering generation rate constraints," *Proc. IEE*, Vol. 129(C), pp. 285–289, November 1982.
- [9] Kothari, M. L., Satsangi, P. S., and Nanda, J., "Sampled data automatic control of interconnected reheat thermal stations consisting generation rate constraints," *IEEE Trans. Power Appar. Syst.*, Vol. PAS-100, No. 5, pp. 2334–2342, May 1981.
- [10] Fosha, C. E., and Elgerd, O. I., "The megawatt frequency control problem: A new approach via optimal control theory," *IEEE Trans. Power Appar. Syst.*, Vol. PAS-89, No. 4, pp. 563–577, April 1970.
- [11] Tacker, E. C., Lee, C. C., Reddoch, T. W., Tan, T. O., and Julich, P. M., "Optimal control of interconnected electric energy systems: A new formulation," *Proc. IEEE*, Vol. 60, pp. 1239–1241, October 1972.
- [12] Calovic, M. S., "Linear regulator design for a load and frequency control," *IEEE Trans. Power Appar. Syst.*, Vol. PAS-91, pp. 2271–2285, 1972.
- [13] Feliachi, A., "Optimal decentralized load frequency control," *IEEE Trans. Power Appar. Syst.*, Vol. PAS-97, No. 2, pp. 379–385, May 1987.
- [14] Kothari, M. L., and Nanda, J., "Application of optimal control strategy to automatic generation control of hydro thermal system," *IEE Proc. Pt. D*, Vol. 135, No. 4, pp. 268–274, July 1988.
- [15] Liaw, C. M., and Chao, K. H., "On the design of an optimal automatic generation controller for an interconnected power system," *Int. J. Control*, Vol. 58, pp. 113–127, 1993.
- [16] Ibraheem, and Kumar, P., "Current status of the Indian power system and dynamic performance enhancement of hydro power systems with asynchronous tie lines," *Electric Power Comp. and Syst.*, Vol. 31, pp. 605–626, 2003.
- [17] Nanda, J., Mangla, A., and Suri, S., "Some new findings on automatic generation control of an interconnected hydro thermal system with conventional controllers," *IEEE Trans. Energy Convers.*, Vol. 21, No. 1, pp. 187–194, March 2006.
- [18] Ibraheem, Kumar, P., Hasan, N., Singh, Y., "Optimal automatic generation control of interconnected power system with asynchronous tie-lines under deregulated environment," *Electric Power Comp. and Syst.*, Vol. 40, pp. 1208–1228, 2012.



Gulshan Sharma is presently working as an Associate Professor with the Department of Electrical Engineering, Institute of Technology, Nirma University, Ahmedabad, India. He obtained his B. Tech in Electrical Engineering from Punjab Technical University, Jalandhar, India in 2007 and M. Tech in Power System from Jamia Millia Islamia University, New Delhi, India in 2009 and Ph.D. in Electrical Engineering from Department of Electrical Engineering, Malaviya National Institute of

Technology, Jaipur, India in 2015. He was a postdoctoral research fellow in the Department of Electrical Electronics and Computer Engineering, University of Pretoria, South Africa (2015-2016). He has published number of research papers in international journals and conferences of high repute. His areas of interest are automatic generation control strategies, soft computing techniques and renewable energy integrations to the conventional power systems.