

# Automatic Fluid-Structure Interaction Modeling and Analysis of Butterfly Valve Using Python Script

N. Guru Prasath, Sangjin Ma, Chang-Wan Kim

**Abstract**—A butterfly valve is a quarter turn valve which is used to control the flow of a fluid through a section of pipe. Generally, butterfly valve is used in wide range of applications such as water distribution, sewage, oil and gas plants. In particular, butterfly valve with larger diameter finds its immense applications in hydro power plants to control the fluid flow. In-lieu with the constraints in cost and size to run laboratory setup, analysis of large diameter valves will be mostly studied by computational method which is the best and inexpensive solution. For fluid and structural analysis, CFD and FEM software is used to perform large scale valve analyses, respectively. In order to perform above analysis in butterfly valve, the CAD model has to recreate and perform mesh in conventional software's for various dimensions of valve. Therefore, its limitation is time consuming process. In-order to overcome that issue, python code was created to outcome complete pre-processing setup automatically in Salome software. Applying dimensions of the model clearly in the python code makes the running time comparatively lower and easier way to perform analysis of the valve. Hence, in this paper, an attempt was made to study the fluid-structure interaction (FSI) of butterfly valves by varying the valve angles and dimensions using python code in pre-processing software, and results are produced.

**Keywords**—Butterfly valve, fluid-structure interaction, automatic CFD analysis, flow coefficient.

## I. INTRODUCTION

**B**UTTERFLY valve is commonly used to control fluid flow where the pressure drop is relatively low in applications like's shutoff valves or throttling valves. This typical butterfly valve varies the performance in different angles of the valve positions. Therefore, inappropriate selection of the valve angles leads to reduce the life span of the valve disk. So, the fluid analysis of the valve and structure analysis of the valve helps to choose the high performance angle of the butterfly valve.

In literature, many researchers have performed CFD analysis to identify flow behavior and structural effects of various angles of the valve to withstand the pressure developed by the fluid flow in those opening conditions [1]. For seven different angles of the valve, the hydrodynamic load in butterfly valve are studied in analytical and compared with experimental results. Then, the hydrodynamic effect of the butterfly valve is calculated under the various conditions to estimate the effects of disk shape and their deformation, surface roughness and pressure variation parameters are studied [2]. Afterwards, the

effect of Reynolds number at various angles of opening butterfly valve is studied. Additionally, the pressure loss coefficient is also evaluated. Finally, permanent pressure loss coefficient is computed, and their dependence is analyzed to understand quantitatively [3]. In [4], two different sizes of the butterfly valve are selected to study their performance factor and results of the analysis. Moreover, the load bearing capacity is also checked. Then, the FSI of large diameter of butterfly valve is analyzed in various angles to find out the performance of the valve and safety factor of the structure [5]. To achieve better performance of butterfly valve in various aspects the FSI is performed and integrated with optimization to produce better efficient model [6]. The metamodel optimization is employed to reduce in weight of butterfly valve and satisfies the constraints like safety of the valve and pressure loss coefficient. Finally, the optimal shape and reference model of FSI is compared.

From the above researches, most of the works are using the commercial software to model the geometry of the butterfly valve, and further analyses are taken place. However, during the modeling part, especially changing the dimension and valve angles is time consuming process. In this paper, python code was developed to create and complete pre-processing setup automatically using Salome software. Afterwards, CFD analysis is taken place in FLUENT software, and finally the pressure from surface of the valve is applied as boundary conditions in structural model and analysis are taken place; results are shown in respective analysis. This above process will helpful for industries where the performance of the butterfly valve in various dimensions in limited amount of time is important.

## II. GOVERNING EQUATION

To predict the flow behavior inside the butterfly valve, Navier-Stokes equations are included in order to absorb the effects of turbulence on mean flow properties as Reynolds-Averaged Navier-Stokes (RANS) equation which is given as:

$$\bar{u}_j \frac{\partial \bar{u}_i}{\partial x_j} = g_j - \frac{1}{\rho} \frac{\partial \bar{p}}{\partial x_i} - \frac{\partial \overline{u'_i u'_j}}{\partial x_j} + \nu \frac{\partial^2 \bar{u}_i}{\partial x_j^2} \quad (1)$$

where  $u$ ,  $i$  and  $j = 1-3$  are mean velocity of the fluid and Reynolds-averaged components in all directions, respectively.  $\partial \overline{u'_i u'_j}$  is considered as Reynolds stress.

In this butterfly analysis, the structural analysis is also performed. In this analysis, deformation of the valve is a small value. Therefore, one way FSI coupling is taken for this analysis and governing equation is considered as:

Guru Prasath N. and Sangjin Ma are with the Computer Aided Design & Engineering Lab, Department of Mechanical Engineering, Konkuk University, South Korea (phone: 02-450-3543; e-mail: guruprasathamav@gmail.com, fjjang82@naver.com).

Chang-Wan Kim\* is a professor, Department of Mechanical Engineering, Konkuk university, South Korea (phone: 02-450-3543; e-mail: goodant@konkuk.ac.kr).

$$M\ddot{\beta} + K\beta = f_p \quad (2)$$

where,  $K$ ,  $M$ , and  $f$  are mass, stiffness, and force matrix, respectively. The pressure from the fluid domain is applied to FSI interface of solid domain.

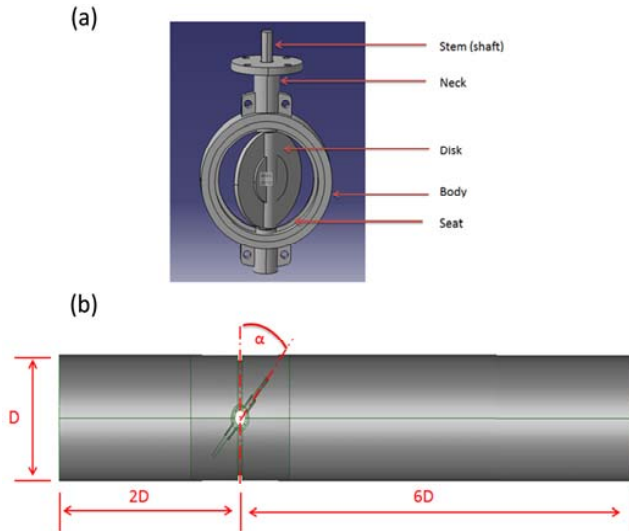

Fig. 1 (a) Structural geometry of the butterfly valve (b) the flow domain of the valve with 2D and 6D of extended upstream and downstream of the valve

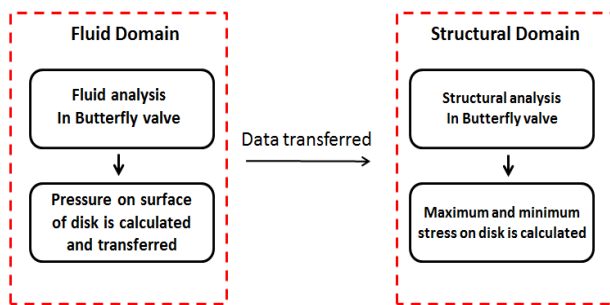

Fig. 2 The schematic process of one-way FSI

### III. FLUID-STRUCTURE INTERACTION (FSI)

Normally, FSI is performed in one-way or two-way coupling method depending on their problem specification. Usually, two-way FSI is performed in large deflection structure problems to understand the behavior of structure depending on the time steps. During this analysis, the data in both solid and structure field data are transferred between them using moving mesh simultaneously. But, in this butterfly valve the deformation on the disk is a relatively small in value. Therefore, one-way FSI is an efficient process for this analysis. Fig. 2 clearly illustrates the schematic flow process of one-way FSI. In fluid domain, the boundary conditions are applied in valve. During fluid analysis, the hydrodynamic pressure was developed in fluid domain and applied over the surface of the disk in butterfly valve. After that, the pressure was imported to the structural analysis as a structural boundary condition, and

analysis was performed to verify the minimum and maximum stress on the disk of the valve.

### IV. FLOW PROCESS OF ANALYSIS

In the existing analysis of the butterfly valve or any other type of valve analysis, the modeling part (pre-processing) is a time consuming process. Some industries need to verify the performance of the valve in various dimensions and angles. Because of the time consuming modeling process, their efficiency is reduced and it takes more time to complete the full analysis. Therefore, it is inappropriate flow process of work in industries to complete butterfly valve FSI analysis. In this paper, a Python script is developed to reduce the time consuming process of pre-processing. This Python script contains the parameters which help to change the dimensions of the butterfly valve and it automatically creates the meshing part of the model. The complete flow process of the analysis is depicted in Fig. 3.

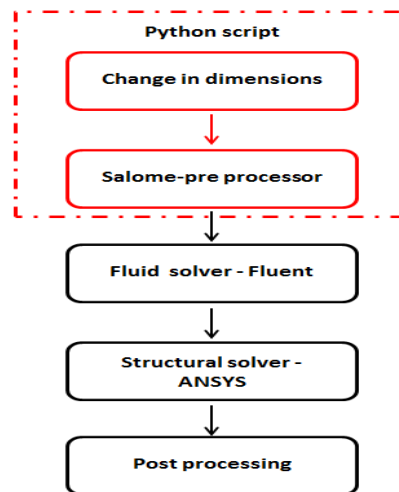

Fig. 3 Flow process of the analysis

### V. COMPUTATIONAL ANALYSIS SETUP

#### A. Butterfly Valve Modeling

The structural and fluid domain of the butterfly valve is shown in Fig. 1. The diameter of the valve is 2.3 m; therefore, in fluid domain, the upstream and downstream of the valve is extended for 2D and 6D, respectively. Similarly, the opening angle of the valve varies depending on the amount of fluid flow; therefore, the valve angle also changed and is used to check the performance. Figs. 4 and 5 show the fluid and structure domains which are used for FSI analyses, and the results are shown below.

#### B. Fluid Analysis

Fluid domain of butterfly valve as shown in Fig. 4 is used for CFD analysis in FLUENT software. In the incompressible steady state analysis for butterfly valve, K-omega SST is selected for turbulence model. Water is considered as working fluid and uniform velocity of 3 m/s is given to the inlet and

opening condition for outlet. No-slip condition is selected for the walls.

During the CFD analysis, the various opening valve angles are selected between 20 and 70 degrees to observe hydrodynamic pressure surface of the disk in the valve, and the results are shown.

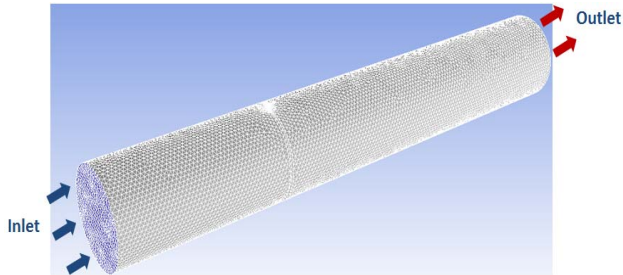

Fig. 4 Boundary conditions of fluid domain

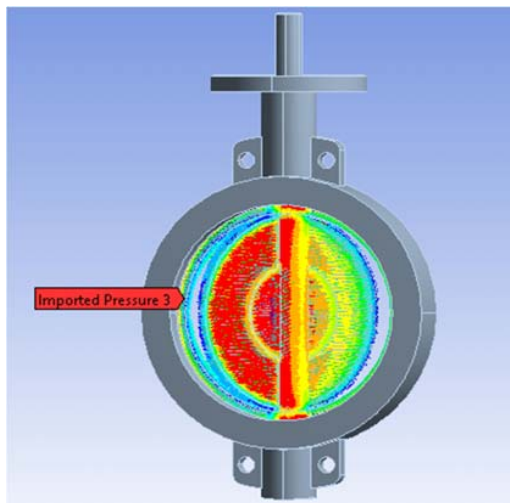

Fig. 5 Shows the FSI interfaces of the structural domain

### C. Structure Analysis

In structural analysis, the butterfly valve's structural model is selected, and surface of disk surface of the valve is considered as FSI interface surfaces as shown in Fig. 5. During fluid analysis, the hydrodynamic pressure is developed; that pressure is imported and applied over the surface of the structural disk to check the maximum and minimum point of stress distribution of the disk. This analysis is one-way fluid-structure analysis. The results from the various angles of fluid analysis are used to check the stress distribution of the surface of the disk.

## VI. RESULT AND DISCUSSION

3D FSI analysis of butterfly valve is performed in typical flow process. In this process, to reduce time consuming pre-processor method, the python script is created and used to create geometry model in order to perform FSI analysis. Afterwards, butterfly valve's pressure distributions and von

Mises stress on the valve of butterfly valves for various angles of opening is analyzed, and the results are given below.

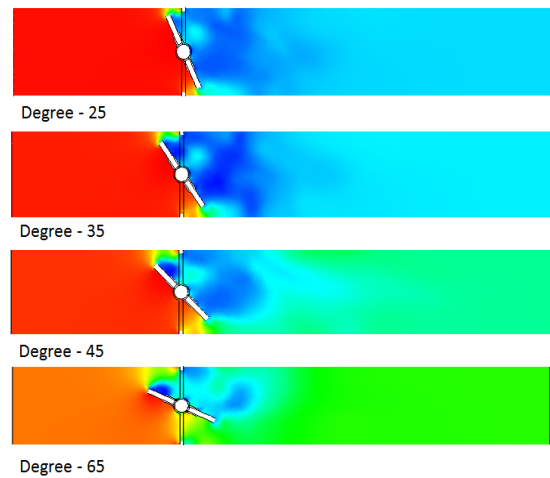

Fig. 6 Pressure distributions of the butterfly valve for various opening angles

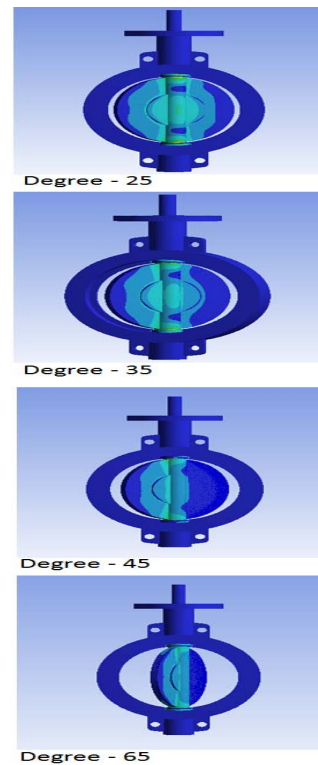

Fig. 7 The Von-mises stress on the structural domain of the butterfly valve

Fig. 6 illustrates the pressure distributions on the butterfly valve for various valve opening angles. In these analyses, the boundary conditions and inlet fluid flow of 3 m/s is selected for every analysis. The hydrodynamic pressure developed in the valve surface is transferred to the structural domain FSI interface surface as shown in Fig. 5, and their pressure

distribution and von Mises stress of the butterfly valve are shown in Figs. 6 and 7, respectively.

Throughout the working procedure, the preprocessor of the analysis was created using Python script to reduce time duration, and the remaining solver and post-processing was performed to validate the typical FSI results of the butterfly valve.

## VII. CONCLUSION

The 3D FSI analysis of butterfly valve is performed in various opening angles of the valves, and the results are shown. The typical FSI flow process and developed python script in pre-processing help to reduce consuming time in order to create geometry model. This Python script made a convenient way to change the dimensions, valve angles, and mesh sizes of the butterfly valve by changing the parameters in the Python code. The parameters of dimensions in the code will make a suitable way for the industries to check the performance of the valves in various dimensions and angles. The future work of this paper is to make the complete automatic flow process of FSI flow process using python code.

## ACKNOWLEDGMENT

This research was supported by the National Research Foundation of Korea (NRF) grant funded by the Ministry of Science, ICT & Future Planning (No.2016R1A2B2015794). Technology Innovation Program (10048305, Launching Plug-in Digital Analysis Framework for Modular system Design) funded by MOTIE.

## REFERENCES

- [1] Fangbiao Lin and Gerald A. Schohl, "CFD prediction and validation of butterfly valve hydrodynamic forces," world water and environmental Resources Congress, 2004.
- [2] Farid Vakili-Tahami, Mohammad Zehsaz, Mahdi Mohammadpour and Ali Vakili-Tahami, "Analysis of the hydrodynamic torque effects on large size butterfly valves and comparing results with AWWA c504 standard recommendations" *Journal of Mechanical science and Technology*, 2012, pp. 2799-2806.
- [3] Naveen Kumar, V seshardi and Yogesh kumar, "Parametric study of flow characteristics of butterfly valve using CFD," *International Journal of Emerging Technology and Advanced Engineering*, vol. 5, 2015.
- [4] Aniruddha V Kapre and Yogesh Dodia, "Flow analysis of butterfly valve using CFD," *International Journal of Research in Engineering and Technology*, vol. 4, 2015, pp. 95-99
- [5] Xue Guan Song, Lin Wang and Young Chul Park, "Fluid and structural analysis of a large scale diameter butterfly valve," vol. 8, *Journal of advanced numerical systems*, 2009, pp. 81-88.
- [6] X G Song, L Wang and Y C Park, "Analysis and optimization of a butterfly valve disc," *Proceedings of the Institution of Mechanical Engineers, Part E: Journal of Process Mechanical Engineering*, IMech vol. 223 2009, pp. 81- 89.