

# Assessment of Carbon Dioxide Separation by Amine Solutions Using Electrolyte Non-Random Two-Liquid and Peng-Robinson Models: Carbon Dioxide Absorption Efficiency

Arash Esmaeili, Zhibang Liu, Yang Xiang, Jimmy Yun, Lei Shao

**Abstract**—A high pressure carbon dioxide (CO<sub>2</sub>) absorption from a specific gas in a conventional column has been evaluated by the Aspen HYSYS simulator using a wide range of single absorbents and blended solutions to estimate the outlet CO<sub>2</sub> concentration, absorption efficiency and CO<sub>2</sub> loading to choose the most proper solution in terms of CO<sub>2</sub> capture for environmental concerns. The property package (Acid Gas-Chemical Solvent) which is compatible with all applied solutions for the simulation in this study, estimates the properties based on an electrolyte non-random two-liquid (E-NRTL) model for electrolyte thermodynamics and Peng-Robinson equation of state for the vapor and liquid hydrocarbon phases. Among all the investigated single amines as well as blended solutions, piperazine (PZ) and the mixture of piperazine and monoethanolamine (MEA) have been found as the most effective absorbents respectively for CO<sub>2</sub> absorption with high reactivity based on the simulated operational conditions.

**Keywords**—Absorption, amine solutions, Aspen HYSYS, carbon dioxide, simulation.

## I. INTRODUCTION

THE greenhouse gases emission has become one of the most challenging environmental issues during the last few decades and the rising CO<sub>2</sub> concentration in the past 200 years has contributed significantly to the global warming phenomena. A wide range of CO<sub>2</sub> emissions is directly related to consumption of fossil fuels; therefore, invention and development of efficient processes to reduce capital and operational costs as well as the size of equipment for CO<sub>2</sub> capture have attracted wide interest.

Different methods have been developed for CO<sub>2</sub> capture

Arash Esmaeili is with Research Center of the Ministry of Education for High Gravity Engineering and Technology, Beijing University of Chemical Technology, Beijing 100029, China (phone: +8613161777098; e-mail: ar.esmaeili@mail.buct.edu.cn).

Zhibang Liu and Yang Xiang are with Research Center of the Ministry of Education for High Gravity Engineering and Technology, Beijing University of Chemical Technology, Beijing 100029, China (e-mail: 2019400002@mail.buct.edu.cn, xiangy@mail.buct.edu.cn).

Jimmy Yun is with College of Chemical and Pharmaceutical Engineering, Hebei University of Science and Technology, Shijiazhuang, Hebei Province 050018, China and School of Chemical Engineering, The University of New South Wales, Sydney, NSW 2052, Australia (e-mail: jimmy.yun@unsw.edu.au).

Lei Shao is with Research Center of the Ministry of Education for High Gravity Engineering and Technology, Beijing University of Chemical Technology, Beijing 100029, China (corresponding author, phone: +8613641092152; e-mail: shaol@mail.buct.edu.cn).

based on chemical reactions between CO<sub>2</sub> and various types of alkanolamines in both conventional columns and rotating packed beds (RPBs). For example, [1]-[3] studied CO<sub>2</sub> absorption by MEA in a conventional column and RPBs, respectively. The most important advantage of absorption is that absorbents can be regenerated by introducing the CO<sub>2</sub>-rich absorbents into a stripper where off-gas is removed by rising temperature. The drawbacks of chemical absorption processes include high energy consumption and limited loadings created by heat of reaction and the reaction stoichiometry in addition to the problems of corrosion and degradation with some of the absorbents.

The commonly used absorbents are non-sterically hindered amines (non-SHAs) in aqueous solutions such as MEA and diglycolamine (DGA) as primary amine, diethanolamine (DEA) and di-isopropanolamine (DIPA) as secondary amine, methyl-diethanolamine (MDEA) and triethanolamine (TEA) as tertiary amine. Sulfinol-D (mixture of DIPA and sulfolane) and Sulfinol-M (mixture of MDEA and sulfolane) as the combination of chemical and physical absorbents have found some significant applications during the last few decades. The blended amine solutions containing SHAs have been also experimented by scientists and industries. For instance, [4] studied CO<sub>2</sub> absorption by 2-amino-2-methyl-1-propanol (AMP); [5] investigated AMP+MEA in a conventional column; [6] evaluated the blended solution of AMP+PZ; [7] conducted experiments on a number of SHAs; [8] published experimental data for CO<sub>2</sub> removal by MEA, DEA, TEA and AMP; [9] and [10] examined CO<sub>2</sub> capture by diethylenetriamine (DETA)+PZ and aqueous DETA solution respectively in an RPB.

The absorption of CO<sub>2</sub> occurs via a two-step mechanism: (1) the dissolution of CO<sub>2</sub> in the aqueous amine solution, and then, (2) the reaction of the weak acid solution with the weakly basic amine. The first absorption step is controlled by the partial pressure of the CO<sub>2</sub> in the gas feed. Amines can be classified according to the number of hydrogen atoms that have been substituted, as primary (R-NH<sub>2</sub>, where R is a hydrocarbon chain), secondary (R-NH-R') or tertiary (R'-NR-R'') amines [11]. This study investigated the ability of all types of amine solutions as single and blended absorbents to assess their reactivity with CO<sub>2</sub> and select the most appropriate one in terms of absorption efficiency.

II. CHEMISTRY OF THE REACTIONS BETWEEN CO<sub>2</sub> AND AMINES

For primary and secondary amines, such as MEA and DEA, the carbamate formation reaction predominates; this reaction is much faster than the CO<sub>2</sub> hydrolysis reaction. The stoichiometry of the carbamate reaction limits the capacity of primary and secondary amines to approximately 0.5 mole of CO<sub>2</sub> per mole of amine. However, DEA-based amine processes can also achieve loadings of more than 0.5 mole of CO<sub>2</sub> per mole of amine through the partial hydrolysis of carbamate (RNHCOO<sup>-</sup>) to bicarbonate (HCO<sub>3</sub><sup>-</sup>), which regenerates some free amine [11]. Xiao et al. [5] have reviewed the equilibrium reactions of CO<sub>2</sub> with both primary and secondary amines:

Dissociation of water:

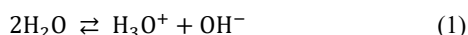

Hydrolysis and dissociation of dissolved CO<sub>2</sub>:

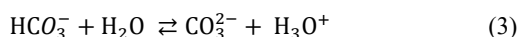
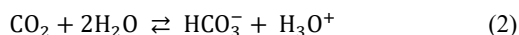

The reaction (R2) is very slow ( $k = 0.026 \text{ s}^{-1}$  at 25 °C) and may usually be neglected.

Protonation of the amine:



Carbamate formation:

Primary amine:



Secondary amine:

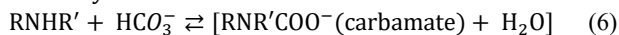

And the subsequent removal of the proton by a base B, which could be an amine, OH<sup>-</sup> or H<sub>2</sub>O, from a zwitterion can be shown as:

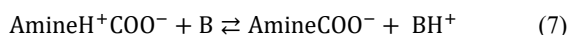

Tertiary amines, such as MDEA, allow higher amounts of CO<sub>2</sub> captured per mole of amine due to a suitable reaction stoichiometry though they present generally a low reaction rate in comparison with primary and secondary amines. This low reaction rate could be associated with a high liquid viscosity that decreases mass transfer rate [12]. The mechanism for the reaction of CO<sub>2</sub> with the tertiary amines is as follows [13], [14]:

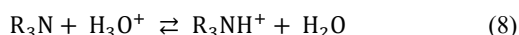

In the case of a SHA such as AMP, the presence of the methyl group significantly reduces the stability of the carbamate bond which results in the preferred formation of the bicarbonate leading to the particularly high loading capacity of

these solvents. SHAs demonstrate certain advantages over conventional non-SHA absorbents for CO<sub>2</sub> removal from gases, such as high absorption rate, higher selectivity and resistance to degradation.

When CO<sub>2</sub> is absorbed in PZ solutions, the zwitterion mechanism used for primary and secondary amines can be adopted to explain the formation of carbamate which is regarded as the result of deprotonation of zwitterion generated through the reaction between CO<sub>2</sub> and PZ, the following equilibrium chemical reactions with the reactions R1 to R3 take place in the liquid phase [15], [16]:

First and second protonation of PZ:

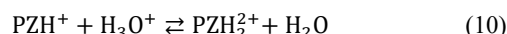
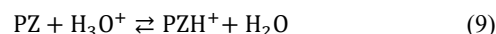

Formation of three carbamate species (PZ carbamate, PZ dicarbamate and protonated PZ carbamate), respectively:

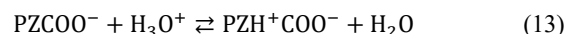
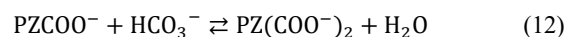
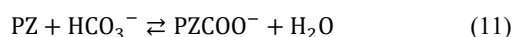

The theory of mass transfer with chemical reaction can be used to analyze the experimental results. The most significant simplification arises from the pseudo-first-order assumption for kinetics. This assumes the concentration of amine to be constant in the liquid boundary layer. Such simplification transforms the second-order reaction expression of CO<sub>2</sub> with an amine to a first-order expression [17]:

$$r_{\text{CO}_2} = k_{2,\text{Am}} [\text{Amine}]([\text{CO}_2] - [\text{CO}_2]^*) \quad (14)$$

$$r_{\text{CO}_2} = k_1 ([\text{CO}_2] - [\text{CO}_2]^*) \quad (15)$$

where  $k_{2,\text{Am}}$  (m<sup>3</sup>/kmol.s) is the second-order reaction rate constant; [Amine] and [CO<sub>2</sub>] are amine and CO<sub>2</sub> concentration (kmol/m<sup>2</sup>.s) respectively, [CO<sub>2</sub>]<sup>\*</sup> is the equilibrium concentration of CO<sub>2</sub>;  $k_1$  (1/s) is the rate constant for the pseudo-first-order reaction and defined as:

$$k_1 = k_{2,\text{Am}} \cdot [\text{Amine}] \quad (16)$$

The reaction kinetics of CO<sub>2</sub> with MEA has been studied extensively in the literature [1]. Regardless of the experimental techniques and conditions, all the data for the reaction of CO<sub>2</sub> with MEA are in very good agreement. The first-order reaction rate for MEA was suggested as follows for the temperature range of 4.8-35°C and MEA concentration of 0.0152-0.177 M [18]:

$$r_{\text{CO}_2-\text{MEA}} = k_{2,\text{MEA}} [\text{MEA}][\text{CO}_2] \quad (17)$$

$$\log k_{2,\text{MEA}} = 10.99 - \frac{2152}{T} \quad (18)$$

The reaction rate of CO<sub>2</sub> absorption into a blended amine solution can be considered as a rapid pseudo-first-order reversible reaction and expressed as [19]:

$$N_{\text{CO}_2} = \frac{\sqrt{D_{\text{CO}_2} (k_{2,1\text{st Amine}} \cdot C_{1\text{st Amine}} + k_{2,2\text{nd Amine}} \cdot C_{2\text{nd Amine}})}}{H_{\text{CO}_2}} (P_{\text{CO}_2, \text{bulk}} - P^*_{\text{CO}_2}) \quad (19)$$

### III. SIMULATION OF CO<sub>2</sub> ABSORPTION BY AMINE SOLUTIONS

The simulation of CO<sub>2</sub> absorption from a specific gas was conducted by different kinds of absorbents in a conventional

column with 10 trays using Aspen HYSYS simulator to estimate the outlet CO<sub>2</sub> concentration, absorption efficiency and CO<sub>2</sub> loading so as to choose the most proper absorbent solution in terms of CO<sub>2</sub> absorption rate. Therefore, the studies of required parameters, data and correlations such as Gibbs free energy, binary interaction coefficients and etc., have been avoided by application of the property package of Acid Gas-Chemical Solvent and the main focus of interest is absorption efficiency. The schematic of absorption process is depicted in Fig. 1.

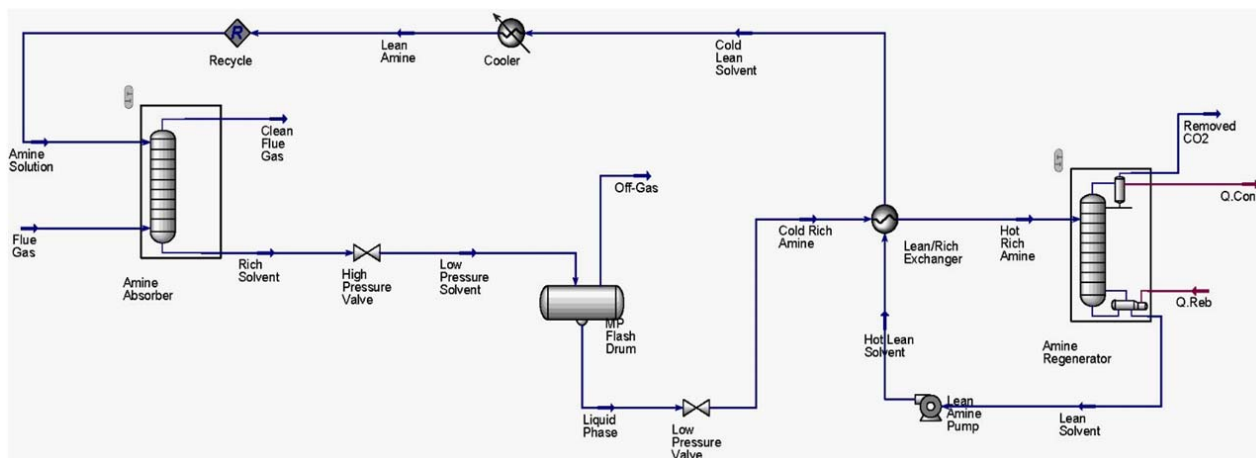

Fig. 1 The schematic CO<sub>2</sub> absorption process by using amine solution in Aspen HYSYS

Nine single amine absorbents and 15 blended amine solutions have been investigated. The single amine solutions include PZ, MEA, DGA, DIPA, DEA, MDEA, TEA, Sulfinol-D (30 wt% DIPA+15%Sulfolane) and Sulfinol-M (30wt% MDEA+15%Sulfolane) while the latter two are considered as a mixture of chemical and physical absorbents. All these solutions were introduced into the column with a concentration of 45 wt% and flow rate of 850 kmol/hr. The appointed concentration of 45 wt% makes the model able to be converged in Aspen HYSYS by all chosen single absorbents. The blended amine solutions are divided into two parts: the first part constitutes PZ+MEA, PZ+DGA, PZ+MDEA, PZ+DEA, PZ+TEA, MEA+DGA, MEA+MDEA, MEA+DEA and MEA+TEA in contact with the gas separately with a concentration of 30 wt% and flow rate of 500 kmol/hr, the second part comprises DIPA+PZ, DIPA+MEA, DIPA+DGA, DIPA+DEA, DIPA+MDEA and DIPA+TEA which were introduced into the column separately with a concentration of 30 wt% and flow rate of 850 kmol/hr. The second part adopted a higher flow rate because the blended DIPA solutions with a flow rate of 500 kmol/hr could not be converged by Aspen HYSYS in the column including ten trays with the specific gas composition. In this study, absorption efficiency of single absorbents is not compared with that of the blended solutions. Some of these blended solutions, such as PZ+MEA [20], [21] and PZ+MDEA [22]-[24] have been studied in the literature.

The molar composition of the gas was 27.36% CO<sub>2</sub>, 34.73% CO, 37.49% H<sub>2</sub>, 0.19% CH<sub>4</sub> and 0.23% H<sub>2</sub>O. The gas was introduced into the column in the conditions 35 °C, 58.5 barg and 96.8 kmol/hr while all solutions were introduced into the column in 45 °C, 59.0 barg to investigate CO<sub>2</sub> absorption. The Acid Gas-Chemical Solvent property package is based on the Electrolyte NRTL model for electrolyte thermodynamics [23] and Peng-Robinson equation of state for vapor phase and liquid hydrocarbon phase properties. This property package is based on extensive research and development in rate-based, simulation of chemical absorption process and molecular thermodynamics models for aqueous amine solutions, it contains the parameters identified from regression of thermodynamic and physical property data such as VLE and heat of absorption for amine solutions. It is highly recommended the rate-based model is used instead of equilibrium model for the simulation of CO<sub>2</sub> absorption, the characteristic that distinguishes this model from the equilibrium is the accuracy of results in such a way that the rate-based model considers the following parameters in order to predict the performance of CO<sub>2</sub> absorption process and the required energy of solvent regeneration: mass transfer correlation, thermodynamics and kinetics model, heat transfer correlation, physicochemical properties (density, viscosity, diffusivity, surface tension, and etc.) and flow model.

The correlations used to simulate the CO<sub>2</sub> absorption are illustrated in Table I. The investigation and comparison of

CO<sub>2</sub> absorption capability with a wide range of amine absorbents has not been conducted in previous studies.

TABLE I  
THE MODELS AND CORRELATIONS USED FOR SIMULATION OF CO<sub>2</sub>  
ABSORPTION BY AMINE SOLUTION

Model Approach	Used Correlation
Flow model	V-Plug
Liquid density	Clarke model
Liquid viscosity	Jones-Dole model
Liquid surface tension	Onsager-Samaras model
Binary diffusivity	Nernst-Hartley model
Thermal conductivity	Riedel model
Mass transfer	AICHE model
Heat transfer coefficient	Chilton and Colburn
Liquid Film resistance	Discrxn model
Vapor film resistance	Film model

#### A. Comparison of Single Amine and Blended Amine Solutions

For the nine single amine solutions with 45 wt% and 850 kmol/hr by considering no lean-CO<sub>2</sub> loading, the following order was obtained from the strongest absorbent to the weakest based on the kinetics parameters which are shown in Tables II and III for zwitterion and protonated amine formation (reactions 5, 6, 8) as well as electrolytes formation (reactions 2, 11, 12) respectively. This order clearly shows the extent of chemical absorption and reactivity. These results are generally compatible with the previous experimental studies on some of amine absorbents. For instance, [10], [17], [25] and [26] and have carried out experiments and calculated the second order reaction rates for some of single and blended alkanolamines applied in this study and acquired almost the same order and their results verify the model used in this study.

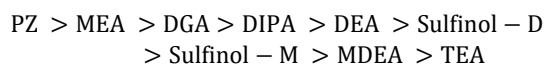

TABLE II  
KINETICS PARAMETERS OF CO<sub>2</sub> ABSORPTION BY PRIMARY, SECONDARY AND TERTIARY AMINES

Solvent	Type of reaction	<i>k</i>	<i>E<sub>a</sub></i> (cal/mol)
MEA [27]	forward	9.77E+10	9855.8
	backward	2.18E+18	14138.4
DGA [27]	forward	1.94E+15	15813
	backward	3.0E+26	25287
DIPA [27]	forward	4.09E+09	9563.1
	backward	2.16E+19	15021
DEA [27]	forward	6.48E+16	5072
	backward	1.43E+17	11497
MDEA [28]	forward	6.85E+10	9029
	backward	6.62E+17	22131
TEA [18]	forward	2.02E+11	8837
	backward	5.02E+18	22288

The CO<sub>2</sub> removal by PZ resulted in the off-gas with only 61.2 ppm CO<sub>2</sub> in outlet as this absorbent has the highest reaction rate with CO<sub>2</sub>, while such absorption by TEA brought about an outlet CO<sub>2</sub> to concentration of 22184.8 ppm as this

solvent is subject to the lowest reaction rate in the same concentration and operational conditions. The reason can be attributed to a higher reactivity resulting from the higher reaction heat of PZ with CO<sub>2</sub>.

TABLE III  
KINETICS PARAMETERS OF BICARBONATE AND SPECIES OF PZ CARBAMATE FORMATION [28]

Type of Electrolyte	Type of reaction	<i>k</i>	<i>E<sub>a</sub></i> (cal/mol)
Bicarbonate	forward	1.33E+17	13249
	backward	6.63E+16	25656
PZ carbamate	forward	1.70E+10	319
	backward	3.40E+23	14160
PZ bicarbamate	forward	1.04E+14	8038.3
	backward	3.20E+20	8692

This order can be illustrated as CO<sub>2</sub> absorption efficiency which is depicted in Fig. 2. Efficiency term,  $\eta$ , is defined as the percentage of CO<sub>2</sub> removed from the inlet gas stream of the column by absorption process and expressed as [25]:

$$\eta = \left[ 1 - \left( \frac{y_{\text{CO}_2, \text{out}}}{1 - y_{\text{CO}_2, \text{out}}} \right) \left( \frac{1 - y_{\text{CO}_2, \text{in}}}{y_{\text{CO}_2, \text{in}}} \right) \right] \times 100 = \left[ 1 - \frac{y_{\text{CO}_2, \text{out}}}{y_{\text{CO}_2, \text{in}}} \right] \times 100 \quad (20)$$

Consequently, PZ possesses the highest efficiency of 99.98% for CO<sub>2</sub> removal while TEA has the lowest efficiency of 93.98%; in other words, PZ is able to absorb more CO<sub>2</sub> because of carbamate formation and higher reaction heat; nevertheless, TEA has slower reaction rate due to lowest order of magnitude in its second order reaction rate constant and indirect reaction with CO<sub>2</sub>.

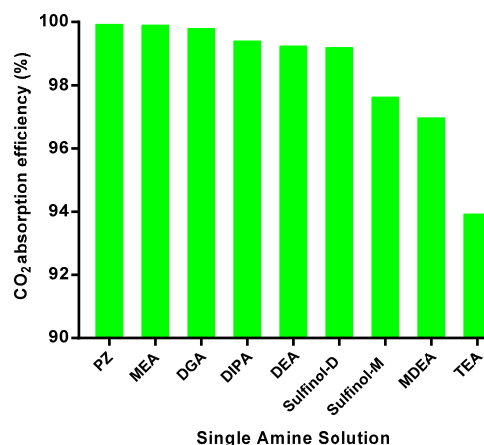

Fig. 2 CO<sub>2</sub> removal efficiency by 45wt% single amine solutions with flow rate of 850 kmol/hr

Aroonwilas et al. [25] studied five different single amine solutions as MEA, DEA, AMP, DIPA and MDEA with a constant concentration 3.0 kmol/m<sup>3</sup> for CO<sub>2</sub> removal. According to their studies with the mentioned absorbents, MEA has obtained the highest amount of CO<sub>2</sub> absorption while MDEA has attained the lowest in terms of CO<sub>2</sub> absorption efficiency as well as reaction heat which is similar to the achieved results in this study.

The order of CO<sub>2</sub> loading ( $\alpha$ ) (as molar flow of absorbed CO<sub>2</sub> to molar flow of amine solvent) in the nine absorbents is shown as follows and the detailed data are given in Fig. 3. It is clear that TEA reached the highest CO<sub>2</sub> loading in 0.326 on account of higher reaction stoichiometry, while the minimum CO<sub>2</sub> loading was achieved by MEA in 0.160 owing to having the lowest equilibrium solubility and the fact that its maximum absorption capacity is limited to 0.5 mole CO<sub>2</sub> per mole MEA. Some of these absorbents have been experimentally investigated by [29].

TEA > DIPA > Sulfinol – D > Sulfinol – M > MDE  
> DGA > DEA > PZ > MEA

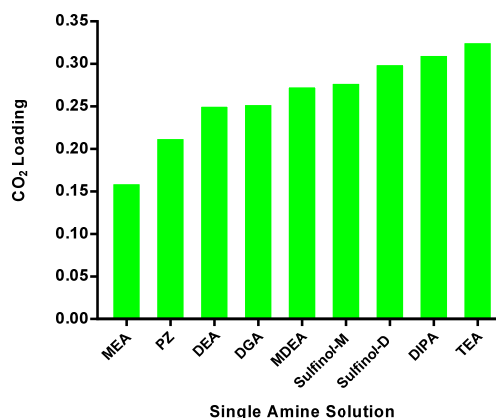

Fig. 3 CO<sub>2</sub> loading in 45wt% single amine solutions with flow rate of 850 kmol/hr

The second-order reaction rate constant between amine and CO<sub>2</sub> is independent of absorbent concentration and it is only a function of temperature, so it can be concluded that the reaction between them is a rapid pseudo-first-order reversible reaction [22]. The second order reaction rate constant for PZ [22], DEA [30], DGA [31], MDEA [14] and TEA [13] are as follows, respectively, the values of which are indicated for the mentioned amine absorbents within 305-335 K in Fig. 4.

$$k_{2,PZ} [\text{m}^3/\text{kmol}\cdot\text{s}] = 4.0 \times 10^{10} \cdot \exp\left(\frac{-4059.4}{T}\right) \quad (21)$$

$$\log k_{2,DEA} [\text{m}^3/\text{kmol}\cdot\text{s}] = 10.4493 - \frac{2274.5}{T} \quad (22)$$

$$k_{2,DGA} [\text{m}^3/\text{kmol}\cdot\text{s}] = 6.66 \times 10^3 \cdot \exp\left(-4823.1\left(\frac{1}{T} - \frac{1}{298}\right)\right) \quad (23)$$

$$k_{2,MDEA} [\text{m}^3/\text{kmol}\cdot\text{s}] = 5.86 \times 10^6 \cdot \exp\left(\frac{-3984}{T}\right) \quad (24)$$

$$k_{2,TEA} [\text{m}^3/\text{kmol}\cdot\text{s}] = 3.311 \times 10^6 \cdot \exp\left(\frac{-4089}{T}\right) \quad (25)$$

The ability of an absorbent to remove CO<sub>2</sub> is dictated by its equilibrium solubility as well as mass transfer and chemical kinetics characteristics [17]. Being a cyclic symmetric diamine, each mole of PZ can theoretically absorb two moles of CO<sub>2</sub> and PZ may favor rapid formation of the carbamates.

The apparent second-order rate constant of PZ has been found to be an order at least higher than that of conventional alkanolamines such as MEA which is shown in Figs. 4 and 5 based on logarithmic-scale. Most of CO<sub>2</sub> is absorbed from the middle to the bottom of column owing to higher driving force between gas and absorbent, the mole fraction of CO<sub>2</sub> in the liquid phase has reached to  $6.79 \times 10^{-6}$  by PZ on the top of the column while the minimum value of that is about  $1.05 \times 10^{-4}$  using DIPA which represents two order of magnitudes difference. In other words, PZ has been able to obtain the similar solubility on tray no.7 from the bottom and there has been less CO<sub>2</sub> concentration on the upper stages to be absorbed but such solubility has attained with a slighter slope by DIPA on tray no.10 which proves that CO<sub>2</sub> absorption by DIPA requires an absorber with higher number of stages and height than that of by PZ to achieve the same solubility. The order shown in Fig. 5 is identical to [26] on MEA, DEA and TEA. Whereas PZ is effective in promoting the rate of CO<sub>2</sub> absorption even at its low concentrations in blend with other amine absorbents, it is known as an activator or promoter in industrial processes.

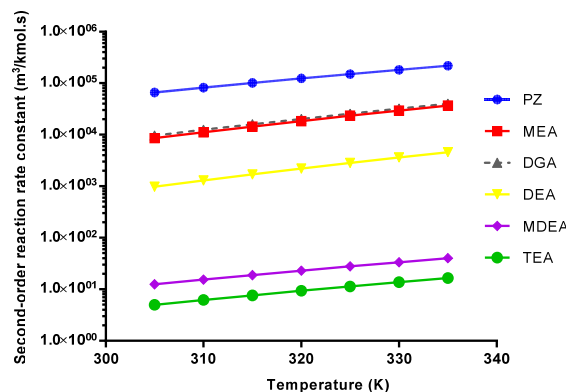

Fig. 4 The estimated values of second-order reaction rate constant for amine absorbents

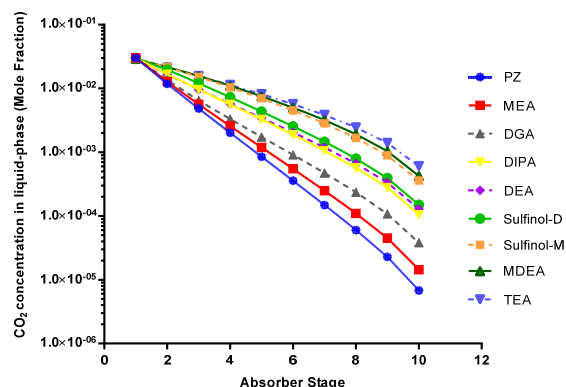

Fig. 5 The values of absorbed CO<sub>2</sub> in 45 wt% single amine solutions with flow rate of 850 kmol/hr

For the blended solutions with 30 wt% and 500 kmol/hr, the following order demonstrates CO<sub>2</sub> absorption efficiency of

nine different mixtures, and in consequence, solution of PZ and MEA possesses the fastest reaction with CO<sub>2</sub> which can be observed in Figs. 6 and 7. Some of these solutions have been studied before, e.g. [25] reported that MEA+MDEA has much more tendency to absorb CO<sub>2</sub> than DEA+MDEA, and our results confirm that the mixture of DEA and MDEA is subject to the lowest absorption efficiency with the outlet CO<sub>2</sub> concentration varying from 19,618 ppm to 14,220 ppm while DEA concentrations varied between 5 wt% and 25 wt%:

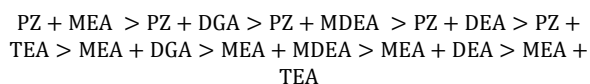

Fig. 6 shows the effect of the blended amine solutions with various PZ concentrations on CO<sub>2</sub> removal. PZ was employed as an activator and mixed with five different absorbents to form 30 wt% solutions while the concentration of PZ in each solution varied from 5 wt% to 25 wt%. Exceptionally, TEA solution was evaluated from 10 wt% due to lack of sufficient reactivity in the solution of 5 wt% PZ + 25 wt% TEA with CO<sub>2</sub> to be converged by this model. It is clear that CO<sub>2</sub> removal was improved by increasing PZ concentration, particularly for the amines with slower reaction rate such as DEA and TEA. After the gas was treated by the solution of PZ+TEA, the outlet CO<sub>2</sub> concentration declined by 93% with an increasing PZ concentration from 10 wt% to 25 wt%, while there was only 42% decrease in the outlet CO<sub>2</sub> concentration for the solution of PZ+MEA with 25 wt% PZ in comparison with that of 5 wt% PZ, in such a way the outlet CO<sub>2</sub> concentration by the solution of 5 wt% PZ+25 wt% MEA is around 421 ppm which is comparatively lower than the same PZ concentration blended with other absorbents. Regardless of PZ+MEA solution, PZ+DGA exhibited a higher CO<sub>2</sub> absorption than other mixtures except the case of 5 wt% PZ+25 wt% DGA in which the outlet CO<sub>2</sub> concentration reached 1450 ppm compared to 1070.1 by 5 wt% PZ+25 wt% MDEA. TEA demonstrated the lowest absorption ability and the outlet

CO<sub>2</sub> concentration was as high as 4412 ppm in the solution of 10 wt% TEA+20 wt% PZ. Similarly, CO<sub>2</sub> removal was simulated by the 30 wt% blended amine solutions with MEA concentration of 5 wt%, 10 wt%, 15 wt%, 20 wt% and 25 wt% and the results are shown in Fig. 7, which illustrates that CO<sub>2</sub> removal performance of MEA with other amines followed the same order as that of PZ with other amines although the outlet CO<sub>2</sub> concentration was 6-8 times higher for the solutions with MEA than those with PZ at the same concentration. The values of CO<sub>2</sub> absorbed by the solutions of MEA+DGA, MEA+MDEA and MEA+DEA were close to each other in the lowest concentration of MEA (5 wt%). These results suggest that the MEA does not influence much at lowest concentration and the effect of those three absorbents (DGA, MDEA and DEA) predominates, while MEA affects CO<sub>2</sub> absorption significantly at higher concentrations (from 10 wt%) and somehow overshadows the effect of the other compounds in the solution.

Fig. 8 depicts CO<sub>2</sub> removal by the blended amine solutions with different concentrations of DIPA as a secondary amine. Contrary to the mixture of PZ with other absorbents that brought about a descending outlet CO<sub>2</sub> concentration with increasing PZ mass ratio, the blended solutions with DIPA demonstrate up or down trends with increasing DIPA concentration depending on their reaction rates with CO<sub>2</sub> as well as CO<sub>2</sub> solubility in these absorbents. Considering the fact that PZ, MEA and DGA have higher reactivity with CO<sub>2</sub> than DIPA, increasing DIPA concentration affected CO<sub>2</sub> absorption reversely and led to a rise in the outlet CO<sub>2</sub> concentration as much as 2.78, 4.86 and 2.15 times, respectively. On the other side, a rise in DIPA concentration in the mixtures of DIPA+DEA caused a slight increase in the outlet CO<sub>2</sub> concentration as 1.11 times because DIPA more promotes CO<sub>2</sub> loading than the reaction rate compared with DEA and finally, brought on higher CO<sub>2</sub> concentration in the outlet gas which has a good consistency with the previous literature [25].

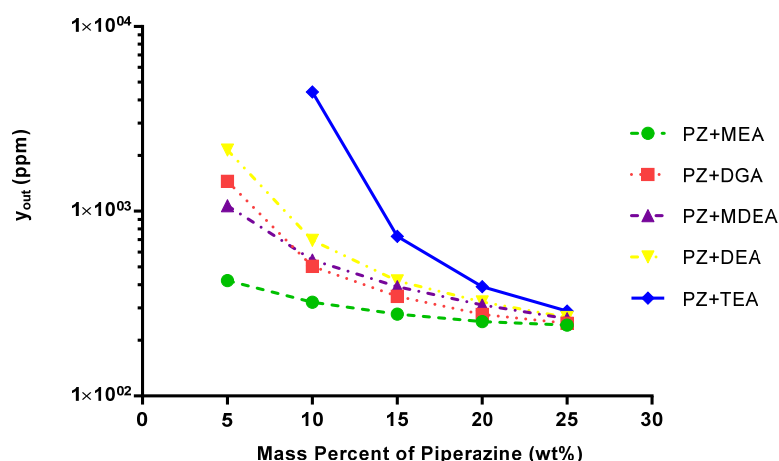

Fig. 6 Comparison of CO<sub>2</sub> absorption by different 30 wt% blended solutions mixed with PZ

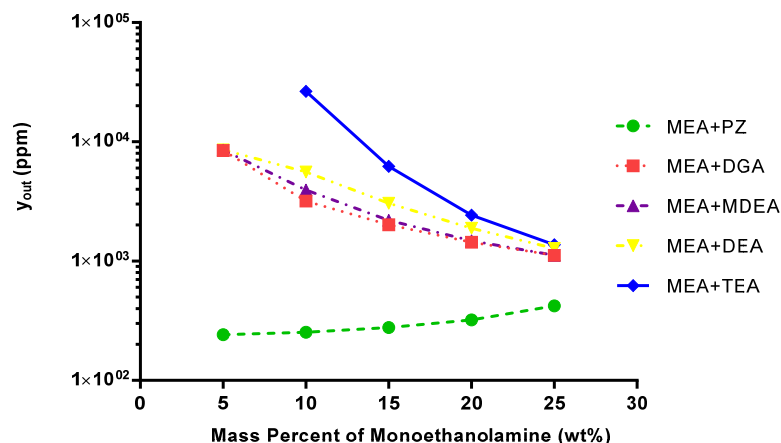

Fig. 7 Comparison of CO<sub>2</sub> absorption by different 30 wt% blended solutions mixed with MEA

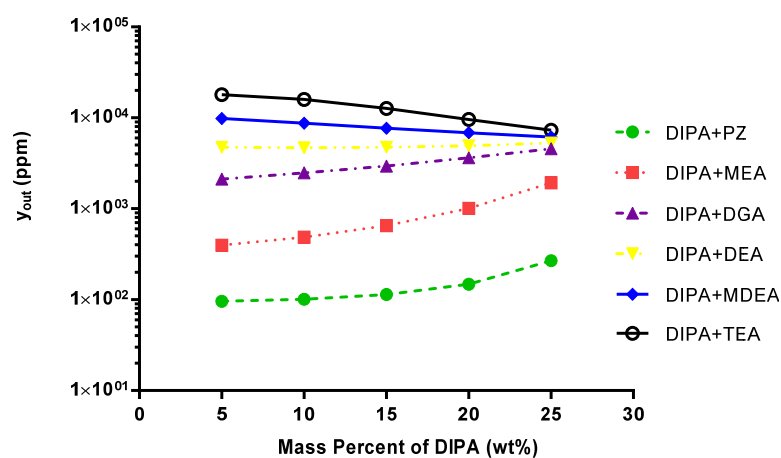

Fig. 8 Comparison of CO<sub>2</sub> absorption by different 30 wt% blended solutions mixed with DIPA

In DIPA+MDEA and DIPA+TEA solutions, both controlling parameters of higher reactivity of DIPA than MDEA and TEA in addition to higher solubility of CO<sub>2</sub> in DIPA compared with MDEA led to the decrease in the outlet CO<sub>2</sub> concentration by 37.6% and 59.5%, respectively. Therefore, DIPA in mixture with tertiary amine solvents makes more efficient blended solutions than that of with other type of amine because it promotes the slow reaction rate of tertiary amine absorbents as an activator in such a way that DIPA worked effectively on the top trays of the column and then higher solubility of CO<sub>2</sub> in MDEA or TEA caused CO<sub>2</sub> reduction on the bottom trays and consequently in the outlet gas. These trends are in good agreement with [25] which shows a mixed kinetic/thermodynamic competition in a blended solution between two reactive components (MEA or DEA and MDEA). Based on their experiments, promoters play a key role in controlling absorption rate in low CO<sub>2</sub> loadings because they react with CO<sub>2</sub> in a faster rate than other amine component to form very stable carbamate components. As CO<sub>2</sub> loading is enhanced, more CO<sub>2</sub> is converted to promoter carbamate resulting in reduction of unreacted promoter to unreacted tertiary amine ratio. Consequently,

tertiary amine obtains its role in estimation of CO<sub>2</sub> absorption rate. When blended amines are used, promoters probably act as primary reactant to absorb CO<sub>2</sub> on upper section of column while the other amine component controls absorption on lower sections.

#### B. Investigation of Operational Parameters on CO<sub>2</sub> Absorption by PZ+MEA

In order to investigate the effect of operational conditions on CO<sub>2</sub> absorption in the column, five parameters, e.g. solution temperature, gas temperature, solution flow rate, gas flow rate and lean-CO<sub>2</sub> loading for the strongest solution, 25wt%PZ+5wt%MEA, were studied, while the effect of streams temperature was assessed simultaneously and that of streams flow rate was also examined together. Pressure and flow rate of the gas and liquid streams are 58.5 barg and 96.8 kmol/hr as well as 59.0 barg and 500 kmol/hr, respectively.

Fig. 9 represents the effect of PZ+MEA solution temperature on CO<sub>2</sub> absorption. It is clear that rising solution temperature resulted in a higher CO<sub>2</sub> removal because high temperature can enhance the reaction rate between the amine solution and CO<sub>2</sub> and thus increased liquid-side mass transfer coefficient despite the fact that higher temperature causes

lower CO<sub>2</sub> solubility in the solution. The effect of gas temperature is shown in Fig. 10, which indicates that increasing gas temperature at a certain amine solution temperature did not affect CO<sub>2</sub> absorption, obviously because the main mass transfer resistance is in liquid film even if gas temperature increase brings about a rising in gas-side mass

transfer coefficient. This observation is in agreement with other studies [32]. The temperature over 60 °C is not a good choice for amine solutions based on the operating conditions and recommendations in literature [10], and thus the investigation was performed up to this temperature.

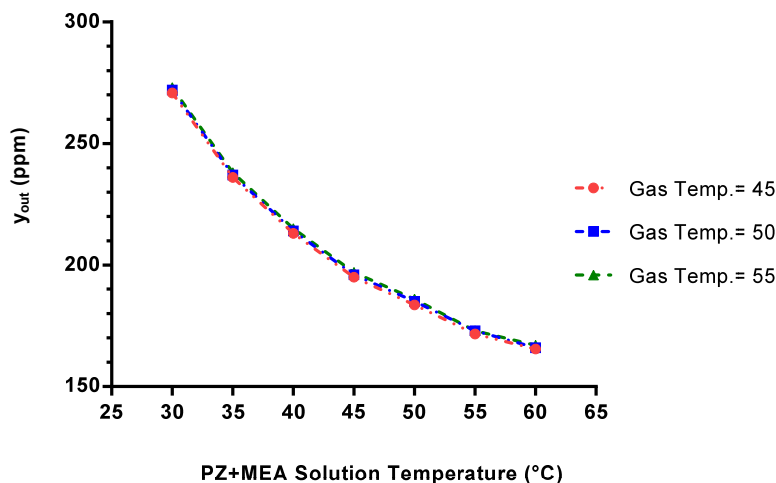

Fig. 9 Outlet CO<sub>2</sub> concentration vs. PZ+MEA solution temperature with three different gas temperatures

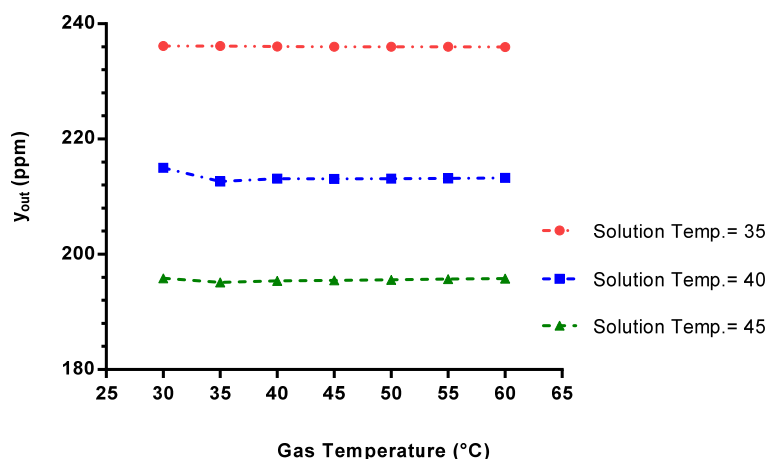

Fig. 10 Outlet CO<sub>2</sub> concentration vs. gas temperature with three different PZ+MEA solution temperatures

The influence of gas flow rate on CO<sub>2</sub> absorption is illustrated in Fig. 11, which shows that higher gas flow rate at a fixed liquid flow rate led to higher outlet CO<sub>2</sub> concentration while the inlet temperature of the gas and absorbent were 35 °C and 45 °C, respectively. A rising gas flow rate from 90 kmol/hr to 130 kmol/hr not only results in higher CO<sub>2</sub> amount per unit time in the column but shortens gas-liquid contact time, thereby causing a lower CO<sub>2</sub> absorption efficiency. Figs. 11 and 12 also indicate that rising PZ+MEA solution flow rate assisted to decrease the outlet CO<sub>2</sub> concentration as a result of higher liquid-side and overall mass transfer coefficients. Furthermore, Fig. 12 clearly indicates that there was negligible difference in the value of absorbed CO<sub>2</sub> with various gas flow rates when PZ+MEA solution flow rate increased from 600

kmol/hr to 900 kmol/hr. Consequently, the flow rate of 600 kmol/hr can be chosen as the minimum required flow of the absorbent where the operating line and the equilibrium curve meet each other.

Fig. 13 illustrates the variation of rich-CO<sub>2</sub> loading (the amount of absorbed CO<sub>2</sub> in rich amine) versus lean-CO<sub>2</sub> loading (the amount of remained CO<sub>2</sub> in lean amine after regeneration) in different solution flow rates. The rich-CO<sub>2</sub> loading increases with rising lean-CO<sub>2</sub> loading up to a specific point depends on the value of solution flow rate, i.e. increasing the amount of CO<sub>2</sub> in lean solution has led to more absorbed CO<sub>2</sub> in rich amine solutions but the maximum solubility is subject to the flow rate so that the minimum flow rate is 600 kmol/hr to achieve rich-CO<sub>2</sub> loading equal to 1.0 and the



lower flow rates were not able to reach this amount of rich loading. On the other hand, the rich-CO<sub>2</sub> loading has declined with increasing solution flow rate in a constant lean-CO<sub>2</sub> loading; this trend is in good agreement with the similar work [21]. Fig. 14 depicts the values of outlet CO<sub>2</sub> in the off-gas

with the variation of lean-CO<sub>2</sub> loading which has increased in various solution flow rates in such a way that there is no much difference between the values of outlet CO<sub>2</sub> for the flow rates of 600 kmol/hr and 650 kmol/hr from the rich-CO<sub>2</sub> loading of 0.35.

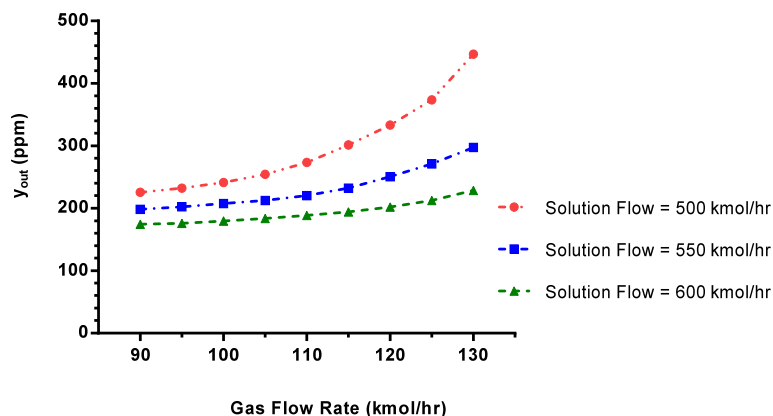

Fig. 11 Outlet CO<sub>2</sub> concentration vs. gas flow rate with three different PZ+MEA solution flow rates

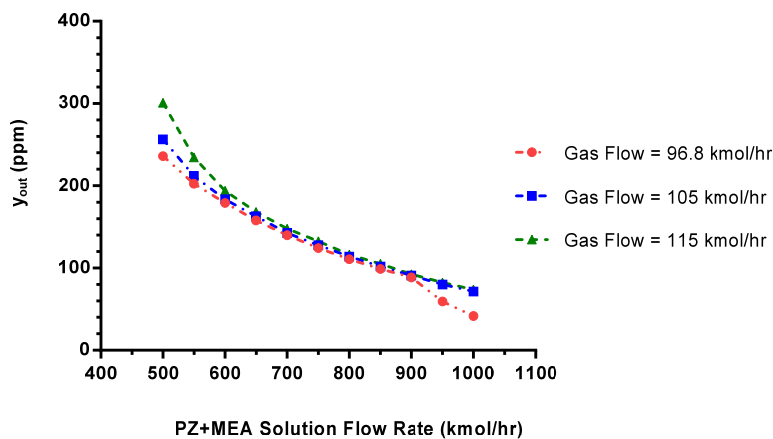

Fig. 12 Outlet CO<sub>2</sub> concentration vs. PZ+MEA solution flow rate with three different gas flow rates

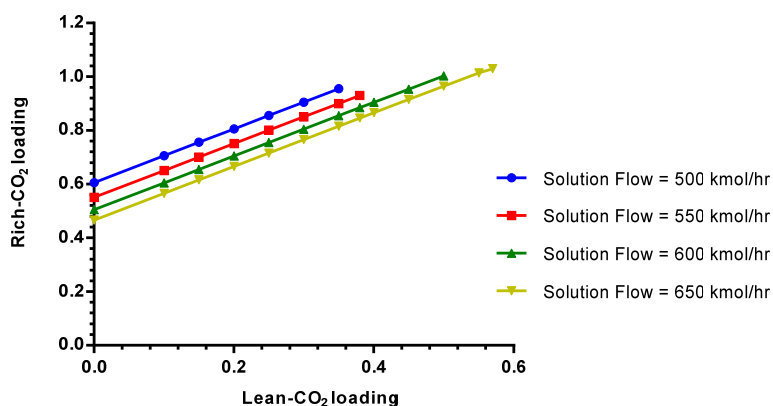
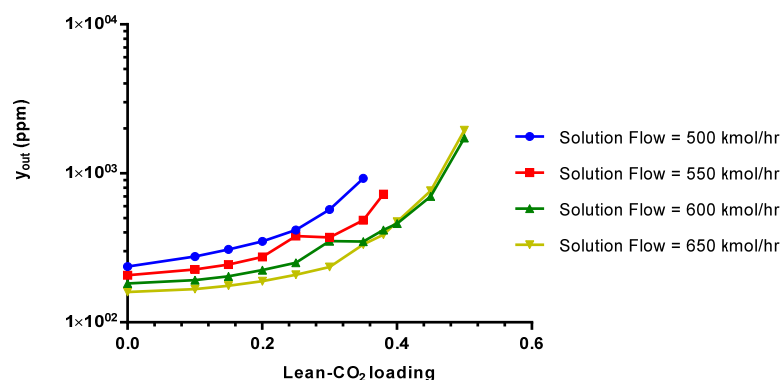

Fig. 13 Rich-CO<sub>2</sub> loading of PZ+MEA solution vs. lean-CO<sub>2</sub> loading with various solution flow rates

Fig. 14 Outlet CO<sub>2</sub> concentration vs. lean-CO<sub>2</sub> loading with various solution flow rates

#### IV. CONCLUSION

The conventional absorption column module in Aspen HYSYS was used to investigate CO<sub>2</sub> removal efficiency of a wide range of single and blended aqueous amine solutions, which include PZ, MEA, DEA, MDEA, DIPA, TEA, DGA, Sulfinol-D and Sulfinol-M as well as PZ+MEA, PZ+DGA, PZ+MDEA, PZ+DEA, PZ+TEA, MEA+DGA, MEA+MDEA, MEA+DEA and MEA+TEA; in addition to DIPA+PZ, DIPA+MEA, DIPA+DGA, DIPA+DEA, DIPA+MDEA and DIPA+TEA. It was found that PZ and the mixture of PZ and MEA were the most appropriate solutions for CO<sub>2</sub> absorption among the single amine absorbents and blended solutions owing to the higher order of magnitude in second-order reaction rate constant, fastest reaction rate and highest efficiency, while TEA exhibited the maximum CO<sub>2</sub> loading on account of its higher equilibrium capacity. Furthermore, increasing the amine solution temperature improved CO<sub>2</sub> removal while variation of gas temperature had a negligible effect on CO<sub>2</sub> absorption. An increase in the gas flow rate or decrease in the PZ+MEA solution flow rate resulted in an obvious rise in outlet CO<sub>2</sub> concentration. It was observed that the outlet CO<sub>2</sub> concentration varied a little with the increase of the gas flow rate from 96.8 kmol/hr to 115 kmol/hr at the PZ+MEA solution flow rate in the range of 600 kmol/hr to 900 kmol/hr. Moreover, enhancing lean-CO<sub>2</sub> loading has led to rising the values of CO<sub>2</sub> in the outlet gas and rich solvent, the results of Figs. 12-14 were useful to estimate the minimum required solution flow rate in this model. This work can provide guideline for the selection of suitable absorbents in CO<sub>2</sub> capture.

#### ACKNOWLEDGMENT

This work was financially supported by the National Natural Science Foundation of China (No. 21676008).

#### NOMENCLATURE

##### Symbols Used

[Amine]	[kmol m <sup>-3</sup> ]	concentration of amine
[CO <sub>2</sub> ]	[kmol m <sup>-3</sup> ]	CO <sub>2</sub> concentration in the liquid bulk
[CO <sub>2</sub> ] <sup>*</sup>	[kmol m <sup>-3</sup> ]	equilibrium concentration of CO <sub>2</sub>
B	[-]	base

<i>C</i>	[kmol m <sup>-3</sup> ]	concentration
<i>D<sub>G,L</sub></i>	[m <sup>2</sup> s <sup>-1</sup> ]	diffusivity of gas in liquid phase
<i>E<sub>a</sub></i>	[cal mol <sup>-1</sup> ]	activation energy
<i>N</i>	[kmol m <sup>-2</sup> s <sup>-1</sup> ]	molar mass-transfer flux
<i>P<sub>CO<sub>2</sub>,bulk</sub></i>	[Pa]	partial pressure of CO <sub>2</sub> in the gas bulk
<i>P<sub>CO<sub>2</sub></sub></i> <sup>*</sup>	[Pa]	equilibrium partial pressure of CO <sub>2</sub>
<i>r</i>	[kmol m <sup>-3</sup> s <sup>-1</sup> ]	reaction rate
<i>T</i>	[K]	absolute temperature
<i>y</i>	[-]	mole fraction of CO <sub>2</sub>
<i>Y</i>	[-]	molar ratio of CO <sub>2</sub> [ <i>y</i> /(1 - <i>y</i> )]

##### Greek Symbols

<i>α</i>	[-]	CO <sub>2</sub> loading
<i>η</i>	[%]	absorption efficiency of CO <sub>2</sub>

##### Subscripts

<i>Am</i>	amine
<i>in</i>	inlet
<i>out</i>	outlet

##### Abbreviations

<i>RNH<sub>2</sub></i>	primary amine
<i>RNHR'</i>	secondary amine
<i>R'NRR''</i>	tertiary amine

#### REFERENCES

- Hikita, H.; Asai, S.; Katsu, Y.; Ikuno, S. Absorption of carbon dioxide into aqueous monoethanolamine solutions, *AIChE J.* 1979, 25, 793-800.
- Lin, C.; Liu, W.; Tan, C. Removal of carbon dioxide by absorption in a rotating packed bed, *Ind. Eng. Chem. Res.* 2003, 42, 2381-2386.
- Jassim, M. S.; Rochelle, G.; Eimer, D.; Ramshaw, C. Carbon dioxide absorption and desorption in aqueous monoethanolamine solutions in a rotating packed bed, *Ind. Eng. Chem. Res.* 2007, 46, 2823-2833.
- Aroonwilas, A.; Tontiwachwuthikul, P. High-efficiency structured packing for CO<sub>2</sub> separation using 2-amino-2-methyl-1-propanol (AMP), *J. Sep. Purif. Technol.* 1997, 12, 67-79.
- Xiao, J.; Li, C.; Li, M. Kinetics of absorption of carbon dioxide into aqueous solutions of 2-amino-2-methyl-1-propanol + monoethanolamine, *J. Chem. Eng. Sci.* 2000, 55, 161-175.
- Seo, D. J.; Hong, W. H. Effect of piperazine on the kinetics of carbon dioxide with aqueous solutions of 2-amino-2-methyl-1-propanol, *Ind. Eng. Chem. Res.* 2000, 39, 2062-2067.
- Bougie, F.; Iliuta, M. C. Analysis of regeneration of sterically hindered alkanolamines aqueous solutions with and without activator, *J. Chem. Eng. Sci.* 2010, 65, 4746-4750.
- Kim, Y. E.; Lim, J. A.; Jeong, S. K.; Yoon, Y. I.; Bae, S. T. Comparison of carbon dioxide absorption in aqueous MEA, DEA, TEA, and AMP solutions, *Bull. Korean Chem. Soc.* 2013, 34, 783-787.
- Yu, C.; Cheng, H.; Tan, C. CO<sub>2</sub> capture by alkanolamine solutions

- containing diethylenetriamine and piperazine in a rotating packed bed, *Int. J. Greenhouse Gas Control*, 2012, 9, 136-147.
- [10] Sheng, M.; Xie, C.; Zeng, X.; Sun, B.; Zhang, L. Intensification of CO<sub>2</sub> capture using aqueous diethylenetriamine (DETA) solution from simulated gas in a rotating packed bed, *Fuel*, 2018, 234, 1518-1527.
- [11] Rufford, T. E.; Smart, S.; Watson, G. C. Y.; Graham, B. F. The removal of CO<sub>2</sub> and N<sub>2</sub> from natural gas: a review of conventional and emerging process technologies, *J. Pet. Sci. Eng.* 2012, 94-95, 123-154.
- [12] Garcia-Abuin, A.; Gomez-Diaz, D.; Navaza, J. M.; Rumbo, A.; Carbon dioxide capture with tertiary amines. Absorption rate and reaction mechanism, *J. Taiwan Inst. Chem. Eng.* 2017, 80, 356-362.
- [13] Sotelo, J. L.; Benitez, F. J.; Beltran-Heredia, J.; Rodriguez, C. Absorption of carbon dioxide into aqueous solutions of triethanolamine, *AIChE J.* 1990, 36 (8), 1263-1266.
- [14] Xu, G.; Zhang, C.; Qin, S.; Wang, Y. Kinetics study of absorption of carbon dioxide into solutions of activated methyl-diethanolamine, *Ind. Eng. Chem. Res.* 1992, 31, 921-927.
- [15] Ermachkov, V.; Kamps, A. P. S.; Speyer, D.; Maurer, G. Solubility of carbon dioxide in aqueous solutions of piperazine in the low gas loading region, *J. Chem. Eng. Data*, 2006, 51, 1788-1796.
- [16] Bougie, F.; Iliuta, M. C. CO<sub>2</sub> absorption in aqueous piperazine solutions: experimental study and modeling, *J. Chem. Eng. Data*, 2011, 56, 1547-1554.
- [17] Bishnoi, S.; Rochelle, G. T. Absorption of carbon dioxide into aqueous piperazine: reaction kinetics, mass transfer and solubility, *J. Chem. Eng. Sci.* 2000, 55, 5531-5543.
- [18] Hikita, H.; Asai, S.; Ishikawa, H.; Honda, M. The kinetics of reactions of carbon dioxide with monoethanolamine, diethanolamine and triethanolamine by a rapid mixing method, *Chem. Eng. J.* 1977, 13, 7-12.
- [19] Zhang, X.; Zhang, C.; Liu, Y. Kinetics of absorption of CO<sub>2</sub> into aqueous solution of MDEA blended with DEA, *Ind. Eng. Chem. Res.* 2002, 41, 1135-1141.
- [20] Dugas, R.; Rochelle, G. Absorption and desorption rates of carbon dioxide with monoethanolamine and piperazine, *Energy Procedia*, 2009, 1, 1163-1169.
- [21] Dugas, R. E.; Rochelle, G. CO<sub>2</sub> absorption rate into concentrated aqueous monoethanolamine and piperazine, *J. Chem. Eng. Data*, 2011, 56, 2187-2195.
- [22] Zhang, X.; Zhang, C.; Qin, S.; Zheng, Z. A kinetics study on the absorption of carbon dioxide into a mixed aqueous solution of methyl-diethanolamine and piperazine, *Ind. Eng. Chem.* 2001, 40, 3785-3791.
- [23] Bishnoi, S.; Rochelle, G. T. Absorption of carbon dioxide in aqueous piperazine/methyl-diethanolamine, *AIChE J.* 2002, 48, 2788-2799.
- [24] Samanta, A.; Roy, S.; Bandyopadhyay, S. S. Physical solubility and diffusivity of N<sub>2</sub>O and CO<sub>2</sub> in aqueous solutions of piperazine and (N-methyl-diethanolamine + piperazine), *J. Chem. Eng. Data*, 2007, 52, 1381-1385.
- [25] Aroonwilas, A.; Veawab, A. Characterization and comparison of the CO<sub>2</sub> absorption performance into single and blended alkanolamines in a packed column, *Ind. Eng. Chem. Res.* 2004, 43, 2228-2237.
- [26] Rahimi, A.; Tavakoli, T.; Saadat, A.; Niksiar, A. Modeling and experimental study of CO<sub>2</sub> removal by alkanolamines in a packed bed, *Sep. Sci. Technol.* 2014, 49, 317-328.
- [27] Borhani, T. N. G.; Akbari, V.; Hamid, M. K. A.; Manan, A. M. Rate-based simulation and comparison various promoters for CO<sub>2</sub> capture in industrial DEA-promoted potassium carbonate absorption unit, *J. Ind. Eng. Chem.* 2015, 22, 306-316.
- [28] Hemmati, A.; Farahzad, R.; Surendar, A.; Aminahmadi, B.; Validation of mass transfer and liquid holdup correlations for CO<sub>2</sub> absorption process with methyl-diethanolamine solvent and piperazine as an activator, *Process Saf. Environ. Protection*. 2019, 126, 214-222.
- [29] Wang, Y. W.; Xu, S.; Otto, F. D.; Mather, A. E. Solubility of N<sub>2</sub>O in alkanolamines and in mixed solvents, *Chem. Eng. J.* 1992, 48, 31-40.
- [30] Blauwhoff, P. M. M.; Versteeg, G. F.; van Swaaij, W. P. M. A study on the reaction between CO<sub>2</sub> and alkanolamines in aqueous solutions, *Chem. Eng. Sci.* 1983, 38, 1411-1429.
- [31] Al-Juaied, M.; Rochelle, G. T. Absorption of CO<sub>2</sub> in aqueous diglycolamine, *Ind. Eng. Chem. Res.* 2006, 45, 2473-2482.
- [32] Lin, C.; Lin, Y.; Tan, C. Evaluation of alkanolamine solutions for carbon dioxide removal in cross-flow rotating packed bed, *J. Hazard. Mater.* 2010, 175, 344-351.