

# Application of vortex tubes for extracting sediments using SHARC software-A case study of the Western canal in the Dez Diversion Weir

A.H.Sajedi Pour, N.Hedayat and Z.Yazdi

**Abstract**—Sediment loads transfer in hydraulic installations and their consequences for the O&M of modern canal systems is emerging as one of the most important considerations in hydraulic engineering projects particularly those which are intended to feed the irrigation and drainage schemes of large command areas such as the Dez and Mogahn in Iran. The aim of this paper is to investigate the applicability of the vortex tube as a viable means of extracting sediment loads entering the canal systems in general and the water intake structures in particular. The Western conveyance canal of the Dez Diversion weir which feeds the Karkheh Flood Plain in Southwestern Dezfoul has been used as the case study using the data from the Dastmashan Hydrometric Station. The SHARC software has been used as an analytical framework to interpret the data.

Results show that given the grain size D50 and the canal turbulence the adaption length from the beginning of the canal and after the diversion dam is estimated at 477 m, a point which is suitable for laying the vortex tube.

**Keywords**—Vortex tube, sediments, western canal, SHARC model

## I. INTRODUCTION

**S**EDIMENT loads whether in the form of suspended or bed loads are emerging as the important hydraulic engineering features that have attracted the attention of experts, researchers and the operators of the irrigation and drainage schemes in the field. This becomes important under circumstances where the watershed management is poor or deficient and considerable volume of the soil layer is eroded in the forms of Gully and Sheet erosions during sudden rain storms of the spring. As the soil is eroded at the sloppy mountain areas, the shear stress of the run-off flow carry with it tons of the eroded soil along the streams into the permanent rivers which in turn changes the hydraulic behavior of the rivers affected as well as their morphology. Such a morphological changes will have numerous hydraulic consequences particularly behind the hydro-electrical and reservoir dams [1 Sajedi 2010]. Sediment transport along the rivers and its gradual accumulation at certain points along the stream particularly behind the dam reservoirs would be far reaching as experience elsewhere has indicated[3]. One of these has reportedly decreased the nominal capacity of the

reservoirs in the Dez regulating and hydro-electrical dams. Not only this has resulted in serious operational problems in the water delivery of the canal systems in command areas but has also led to considerable environmental challenges that are attributed to flushing out of the sediment loads into the river stream which occasionally practiced in some rivers that in turn affect the marine lives wherever it occurs. The operational impact of sediment loads in the canal system has been highlighted by researchers [2 Sajedi et al 2010, 3 Shirin et al 2010]. For this reason the present paper aims to investigate the complex sedimentation processes and the ways in which these could be mitigated in modern canal systems.

## II. PROCEDURE FOR PAPER SUBMISSION

### A. Materials and method

River Dez is one of the largest permanent surface streams of Iran which originates from the Zagros mountain ranges in central Iran. It meanders through the ragged mountains before entering the Khuzestan plateau a few km north of Greater Dezfoul, internationally renown for its food and fiber production potentials. The Dez irrigation and drainage scheme which is a modern network is designed to supply the water requirements of various cash and strategic crops grown in this modern command area. The gross command area is 120,000 ha, out of which about 90,000 is under cultivation. Because of the importance attached to efficient operation and maintenance of this vital scheme for agricultural and economic development, any deficiency in systems' performance would have to be taken into consideration.

Because of the gravity flow in the western canal, a considerable volume of sediment enters into the canal networks which is becoming a major cause for concern. One of the ways in which the sediment impact could be mitigated is to incorporate one or more open vortex tubes across the canal bed to extract the sediment from the main canal through an escape structure as shown in the schematic diagram below.

Hamid Sajedi pour is with the Department of Civil engineering, Abadan Branch, Islamic Azad University, Abadan, Iran (hsajedi29@yahoo.com).

Najaf Hedayat, Department Of water engineering, Dezfoul Branch, Islamic Azad University, Dezfoul, Iran(n.hedayat@yahoo.com).

Zahra Yazdi, Researcher (z46\_yazdi@yahoo.com).

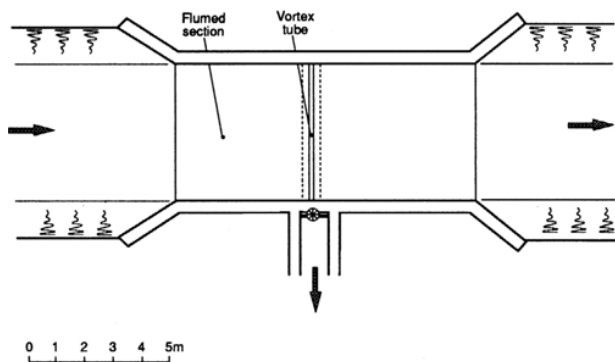

Fig. 1 the schematic diagram of a vortex tube and escape structure

The SHARC software was used to analyze and enter prate data collected from the Dastmashan hydrometric station.

### III. CONCLUSION

#### A. Results and discussion

Results show that the sediment load entry into the water intake structures decreases the conveyance and distribution efficiencies on one hand and entailing much heavier operation and maintenance costs on the other. It is for this reason that the vortex tube and the discharge canal have been designed.

Results further indicate that the water and sediment flow through the tube is diverted toward the discharge canal near the river bed in the canal upstream. This generates a strong vortex flow which necessitates selection of appropriate tube dimensions in order to prevent the sediment entry and their eventual settlement into the tube.

Results further indicate that the model is suitable for regular canal shapes and can be used to simulate the small-size sediments as opposed to larger grain sizes. The overall conclusion being that the model can have important application in hydraulic engineering projects where the focus is to simulate the small grains with a high degree of accuracy. This can be achieved by low costs and high speed.

Results indicate that by increase in the tube diameter the scavation work increases and the water losses also increase.

This would clearly be uneconomical and calling for measures to overcome the problems. One of the ways in which to minimize the adverse impact would be select three four - meters tubes instead of one measuring 12 m. The leads to lesser water losses and requiring a much smaller tube diameter.

Results show that the adaption length can be estimated by the grain size  $D_{50}$ . But given that this length can be estimated by the grain size without considering the turbulence, will be an approximate location. For this reason the adaption length in the Dacse menu should be increased by 50% of the turbulence to arrived at what the software estimated at 477 meters.

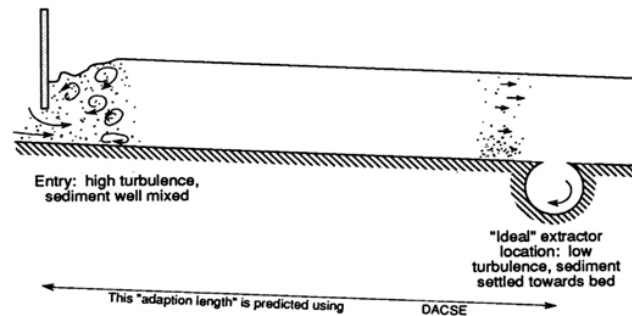

Fig. 2 suitable location for extractor

Results show that the extractor should not be located near the intake structure because at that point the trapping efficiency is low. By the same token, the location of the extractor very far away from the intake structure results in the settlement of the sediments prior to reaching the vortex tube, and as such, raises the water level downstream of the water intake structure.

Results indicate that the software has the potential in finding the most appropriate location or adaption length for laying the vortex tube. This would makes it possible to have the highest trapping efficiency. Results also shows that the sediment load transport and their settlement along the rivers as well as behind the reservoirs would be economically costly and environnementally degrading, all of which call for special measures to overcome the present problems and prevent crises in the future. Results also indicate that the upstream transfer of the sediment loads and their entry in along the river streams could have its root cause in poor vegetation cover in the water basins and poor range management that reportedly affected the features of the soil layers and the erosion that it entails. It is therefore concluded that sedimentation study goes hand in hand with systematice watershed management which has not been forthcoming in the water basins under investigation. It is therefore recommended that prompt measures to be incorporate in the water management and water basin investigation and research in the future. Succes in such a policy depend on a national resolutions which includes the major stakeholder such as the government and the NGO concerned. Successful efforts in this respect would not only ensure guaranteed water supply and distribution to the hardy water users but would ensure the environmental integrity of the water installations as well as preserving the livelihood of the marine lives for not flushing the sediments into the river stream which could be threatening.

REFERENCES

- [1] A.H. Sajedi, (2010), " Analytical study of the sediment formation using the SHARC computer model- A case study of the western water Intake in the Dez diversion weir in Dezful", Iran. M.Sc dissertation, I.Azad University, Dezful, Iran.
- [2] A.H. Sajedi, M. Mashal and N. Hedayat, (2010), " Analytical study of the sediment formation using the SHARC computer model- A case study of the western water Intake in the Dez diversion weir in Dezful", Iran. Proceedings of the National Conference in water, Soil, Plant and agricultural Mechanization, Islamic, Azad University, Dezful, Iran.
- [3] H. Shirin , N. Hedayat and H. Kiamanesh (2010), " Investigating the sedimentation process using the SHARC software- A case study of the in the Eastern water intake of the Dez Diversion Weir in Dezful", Proceedings of the National Conference in water, Soil, Plant and agricultural Mechanization, Islamic, Azad University, Dezful, Iran.
- [4] P Lawrence ,E Atkinson ,P Spark ,C Counsell ,," Procedure for the selection and outline design of canal sediment control structures. March 2001(SHARC Manual)