

Application of particle swarm optimization technique for an optical fiber alignment system

Marc Landry, Azeddine Kaddouri, Yassine Bouslimani and Mohsen Ghribi

Abstract—In this paper, a new alignment method based on the particle swarm optimization (PSO) technique is presented. The PSO algorithm is used for locating the optimal coupling position with the highest optical power with three-degrees of freedom alignment. This algorithm gives an interesting results without a need to go thru the complex mathematical modeling of the alignment system. The proposed algorithm is validated considering practical tests considering the alignment of two Single Mode Fibers (SMF) and the alignment of SMF and PCF fibers.

Keywords—Particle-swarm optimization, optical fiber , automatic alignment.

I. INTRODUCTION

PARTICLE swarm optimization (PSO) is a population based stochastic optimization technique developed in [1]. PSO can be applied to any problem where optimizing one or more process values are required. PSO becomes very attractive because there are few parameters to adjust comparatively to other evolutionary computation techniques such as Genetic Algorithms [2]. PSO has been successfully applied to many applications such as robot autonomous mobile robots [3], renewable energy domains [4], biomedical engineering [3] and control engineering [5]. In this work, we use the particle swarm optimization technique as an alternative for an optical fiber alignment system because of its good performance in several applications. Connecting two fibers is a crucial step for building optical multi-fiber based systems. This task, unique to optical fiber systems, is very difficult because of fibers microscopic dimensions. For example, a typical Single Mode Fiber (SMF) will contain a core of 9 microns in diameter, and a single-mode Photonic Crystal Fibers (PCF) known as endlessly single mode operation fibers [6] will contain a core diameter of as low as 5 microns. This kind of fiber is optimized to exhibit low loss across the widest possible wavelength region from 400 nm to above 2000 nm while keeping an almost constant mode field diameter. The fiber has a standard 125 μm cladding diameter and seems to be compatible with all common fiber tools. However, the interfacing of PCFs to SMFs remains a real challenge. A suitable fiber alignment is always necessary because any misalignment will cause significant optical power losses. Several systems exist nowadays for splicing two SMF fibers. Profile alignment systems proposed

in [7], local injection and detection techniques presented in [8] and of course the fusion splicer given in [9]. These approaches permit the alignment of two SMFs in such way that their cores are coaxial and parallel, with the ends just a few microns apart. The SMFs must be aligned properly or optical loss results. Laterally, longitudinally and angularly misalignment are the three ways one can face. When the SMF fibers are properly aligned, the fusion splicer applies an electric arc to connect the two parts. In [10], a splice-free interfacing has been investigated and a proposed solution was based on tapering a special hybrid fiber with a conventional doped SMF core and large holes in the cladding. Splicing of PCF to SMF has been reported and investigated since the introduction of PCFs in the 1990s [11] [12] but accuracy still remains the main goal for improvement. Previous studies have investigated the use of optimization methods for the multi-fiber alignment systems but not for the PCF-SMF interfacing. For example Nelder and Mead simplex method combined to polynomial interpolation has been experienced [13]. Another study used gradient based and non-gradient based numerical optimization methods [14] [15] [16]. The gradient based methods show result with better optical power, and the non-gradient based methods with faster convergence [14]. The Hamiltonian algorithm has been also used in the active alignment of single-channel fiber optic devices and multichannel-arrayed fiber optic devices, respectively [17]. In this case a Matlab/Simulink application was used for solving Hamiltonian equations and for the feedback control. Genetic algorithms have been used for fiber alignment as well [18] [19].

In this work, we present a new alignment method based on the swarm algorithm optimization technique. This method is used for locating the optimal coupling position with the highest optical power with multi-degrees of freedom alignment. The advantages of this system versus the others are portability and simplicity. Any user regardless of his previous experience with optical fibers coupling can use it. The presented approach is considered especially to avoid power losses caused by the misalignment and the proposed algorithm can be implemented as an improved routine on commercial splicers. It can be used during the process of designing and manufacturing optical fiber components and systems.

II. PARTICLE SWARM OPTIMIZATION

In Particle Swarm Optimization, a group of candidate solutions, referred as particles, are moved around in the solution-space according to two mathematical equations, until the optimized result which is a maximum or minimum of one or

M. Landry, A. Kaddouri and M. Ghribi are with GRETER research group, Department of Electrical Engineering, University of Moncton, Moncton, Canada e-mail: eml7813@umoncton.ca, kaddoua@umoncton.ca, ghribm@umoncton.ca.

Y.Bouslimani is with EMAT research laboratory, Department of Electrical Engineering, University of Moncton, Moncton, Canada e-mail: bousliy@umoncton.ca.

Manuscript submitted to ICECECE 2012 Int. Conf.

multiple variables that satisfy the objective function are found. During each iteration of the algorithm two values related to the swarm of particles must be kept. The first value is the individual particles best position (solution) p_i and the second value is the global best position of the swarm p_g . Particles search the solution-space under two governing equations. The first equation given by :

$$\vec{v}_i(t+1) = \vec{v}_i(t)W + \varphi_1 r_1 [p_i - \vec{x}_i(t)] + \varphi_2 r_2 [p_g - \vec{x}_i(t)] \quad (1)$$

governs the velocity of each particle has when moving towards the p_i and p_g locations. Where φ_1 and φ_2 are constants, r_1 and r_2 are random numbers between 0 and 1. The actual position of the particle in the search-space is given by x . There are n velocities for each particle for an n -dimensional search-space. The velocity must also be specified between the bounds of v_{max} and v_{min} . Also, it is important to be able to slow down the particles as time goes on, so not to oscillate over the optimal solution. The previous velocity is multiplied by the inertial wait W which is defined by the following equation which is then substituted into equation 1:

$$W = (w_1 - w_2) \times \frac{t_{max} - t}{t_{max}} + w_2 \quad (2)$$

where t is the current iteration and t_{max} is the maximum number of allowed iterations.

To update the position of particles during a specific time step the following equation is used:

$$\vec{x}_i(t+1) = \vec{x}_i(t) + \vec{v}_i(t+1) \quad (3)$$

where a unit time step is considered.

III. AUTOMATIC ALIGNMENT SYSTEM

The PSO algorithm is used to find the best coordinates in a three-dimensional space for the coupling of fibre optic strands. The transfer of energy from the light source to the measurement device passing through both fibre optic strands must be at its maximum when the best coordinates are found. The fine adjustments of the position only requires two high precision motors as only two dimensions are considered. The third motor is used to reduce the distance between the two fibers. The alignment system is given by figure 1.

The positioning system is comprised of two high precision stepper motors offering a resolution of 75 nm , a maximum velocity of 4 ms^{-1} and a travel distance of 13 mm .

In this work, the white-light source was used. The maximum transferred power from the light source directly to the measurement instrument passing through one fibre optic strand was $2.3989 \mu\text{W}$. The fibre optic strand is directly connected to the power measurement device via an optical sensor. This instrument also has a GPIB communication port used by the developed software application. A software application was developed using the Microsoft C# language under windows operating system. it allows the user to control each motor in a manual or automatic mode. The automatic mode uses the PSO algorithm. The software also allows the user to change some of the most important parameters in the PSO algorithm

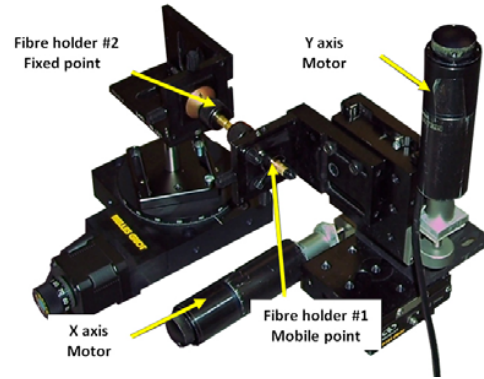

Fig. 1. Positioning Stage

like the inertial weight, initial particle population, maximum number iterations allowed and the algorithm stop criteria. The letter parameter is the absolute error between the best positions of the X and Y coordinates of the current generation and the last generation. When both values are under the desired error the algorithm is stopped. The stop criteria equation is given by :

$$Err > \begin{pmatrix} Px(t) - Px(t-1) \\ Py(t) - Py(t-1) \end{pmatrix} \quad (4)$$

The X, Y coordinates of every particle that is tested is traced in real time on graphic control. It is also possible to watch the movement of the mobile fibre strand through a camera. The view is built in the application. The application interface is shown in figure 2. We see the controls for both X and Y motors, the motor calls, the algorithm parameters, the power measurement, the algorithm progress, the search space and the video feed of the motors.

IV. IMPLEMENTATION PROCESS

The system was assembled on an anti-vibration table. The search-space is the area where the motors will test positions inside the coordinate system that yield the maximum power transfer. The only automatically adjustable positions are the X and Y values. The angles are all aligned by rivets in the table surface. The Z is first fixed at its optimal value. Therefore, the objective is aligning the arrow indicating light path with the target which yields maximum power transfer.

A. Fixing the objective function

The objective function (transmitted power function of x and y position of the fibre optic strand in motion) is traced so that the best positions obtained by the PSO can be compared with the real value. A sweep of the entire two dimensional area function of x and y coordinates was done. The step size between each position was 0.005 mm . Each x and y coordinates were saved as well as the power at this point. Using this collected data the objective function was traced. It is given at figure 3. This method of finding the best coordinates is very time consuming.

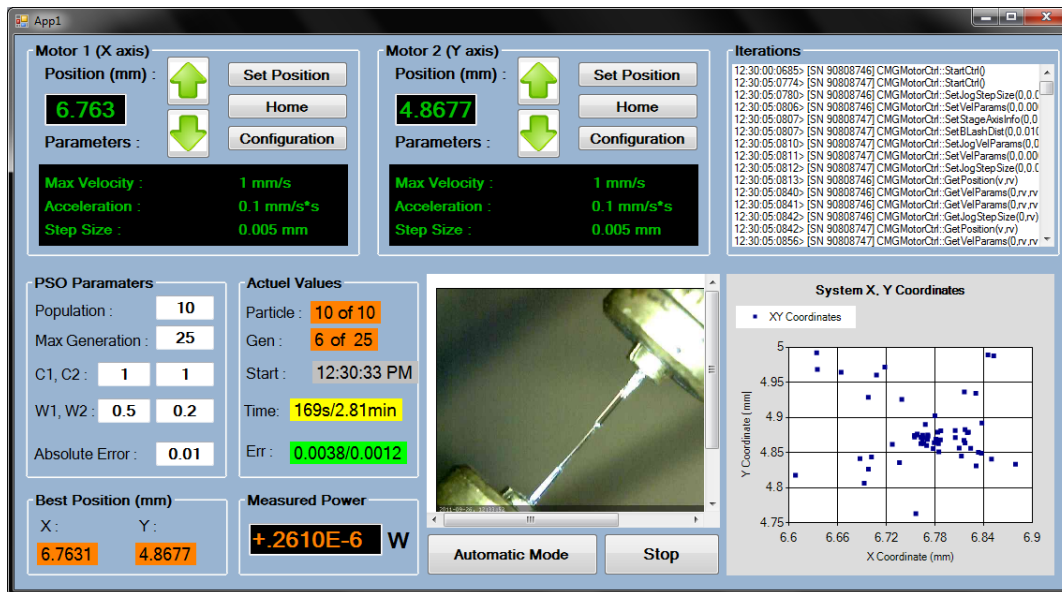

Fig. 2. Program Interface

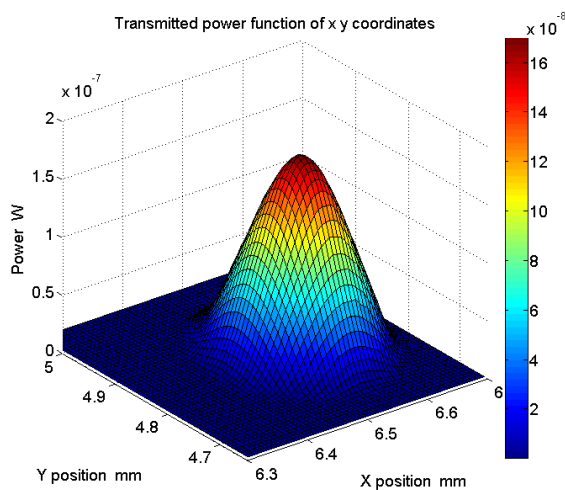

Fig. 3. Objective Function

From this figure 3, there exists only one theoretical position which yields the maximum value of transmitted power. These coordinates are (6.645, 4.880) mm in the XY plane for this specific test. Each time a new set of fibre optic strands are used, the objective function is retraced as to be able to confirm the coordinates of the maximum power transmission. Each new strand can have a different terminating cut causing variations in the results.

B. Testing phases

The goal of the testing is to determine the system performance so it could eventually be installed within a certain process or system. Two main criteria are used. The first is the

number of algorithm iterations the system takes until the best position is found, therefore the number of iterations function of the number of particles has been traced for two values of the stop criteria. The second is the error between the expected coordinates and the obtained by algorithm coordinates.

Testing the performance of the system was done while keeping all algorithm parameters fix except the number of particles. These values were found after several testing and they seem to yield good results. The absolute error between the average value of the x and y coordinates obtained during the current generation and the preceding generation is used as the stop criteria. The used values during the testing phase are given in Table I.

TABLE I
PSO PARAMETERS VALUES

Parameter	Value
C_1	1
C_2	1
W_1	0.5
W_2	0.2

The data was collected over two system configurations. Each configuration varied the number of particles from 8 to 16 in order to evaluate the performance and to ensure that the predicted best coordinates were obtained each time. The predicted best coordinates are found by tracing the objective function explained in section IV-A. In the first configurations, alignment of two SMF optical fibers using a white light source is considered. The second configuration used one SMF and one PCF optical fiber with the same white light source. The table II shows the four configurations considered.

V. EXPERIMENTAL RESULTS

The average number of iterations as a function of the particle population for five tests with the two configurations

TABLE II
DESCRIPTION OF THE TWO CONFIGURATIONS

Config	Source	Fibre	Best Position
1	White light	SMF-SMF	X=6.7700 Y=4.8750
2	White light	SMF-PCF	X=6.6350 Y=4.8550

(the stop criteria of 0.01 mm and 0.01 mm) are given in figure 4.

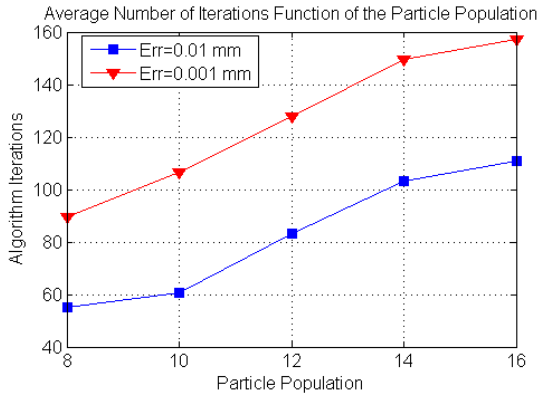

Fig. 4. Average Elapsed Time Function of Particle Population for Err=0.01 mm and Err=0.001 mm

The PSO algorithm uses arbitrary numbers to generate the initial positions of the first generation. If these initial positions are closer to the actual value, the optimum will be found in a shorter elapsed time. The time it takes to do one iteration is factor of the physical setup. On average an iteration during generations 1 to 5 takes a time of 2.5 seconds to complete. This is due to the mechanical setup as well as the power meter. Furthermore, the GPIB communication with the power meter is slow. It was found that the algorithm did not function correctly when not enough write and read time was given to the GPIB communication routine with the measurement device. An iteration during a generation later than 5 usually takes on average 2 seconds.

The table III gives the error that was calculated between the target coordinate and the PSO predicted coordinate for the X and Y coordinate for two different values of the stop criteria and for configuration 1 and 2. Both set of results have their own target values given in table II.

The particle positions drawn on top of the power distribution is given in figure 5 for configuration 1 from table II using two SMF fibers, a population of 10 particles and a stop criteria of 0.01 mm. This figure can be interpreted as a target. The maximum power is obtained when the particles are closest to the center of the target. During the first generation the particles are randomly positioned all over the search-space. As time goes on, the particles move towards the center where the maximum is located. The majority of the particles have located themselves around the inner circle which indicates the maximum has been found. The evolution per iterations of the X and Y system coordinates is traced in figure 6 while using the same parameters.

Figure 7 shows the results for configuration 2 from table II

TABLE III
ABSOLUTE ERROR BETWEEN PREDICTED XY COORDINATES AND PSO OBTAINED XY COORDINATES FOR CONFIGURATION 1 AND 2

Population	Configuration 1		Configuration 2	
	X Err (%)	Y Err (%)	X Err (%)	Y Err (%)
Stop Criteria <0.01 mm				
8	0.66	0.66	0.19	0.05
10	0.91	0.24	0.49	0.09
12	0.48	0.64	0.66	1.35
14	0.98	2.05	0.20	1.72
16	0.30	0.32	0.54	0.50
Stop Criteria <0.001 mm				
8	0.20	0.05	0.34	0.93
10	0.25	0.29	0.30	1.23
12	0.36	2.48	0.50	0.55
14	0.41	1.11	0.38	0.90
16	0.38	0.20	0.27	0.63

using one SMF and one PCF fibre, a population of 10 particles and a stop criteria of 0.01 mm. Figure 8 provides the evolution of X and Y system coordinates function of the number of iterations.

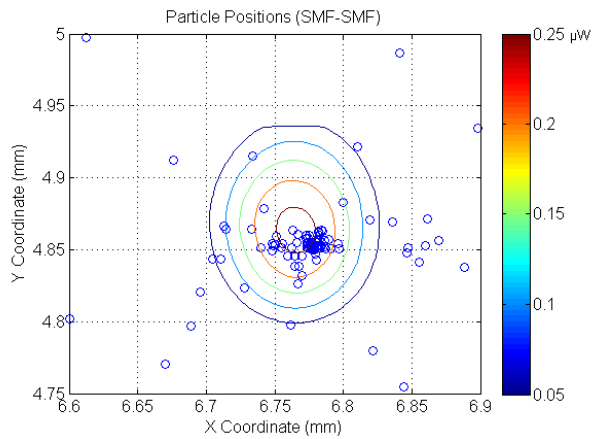

Fig. 5. Particle XY positions (SMF-SMF)

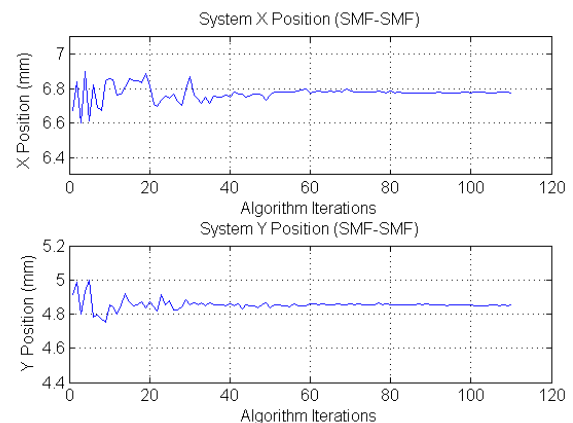
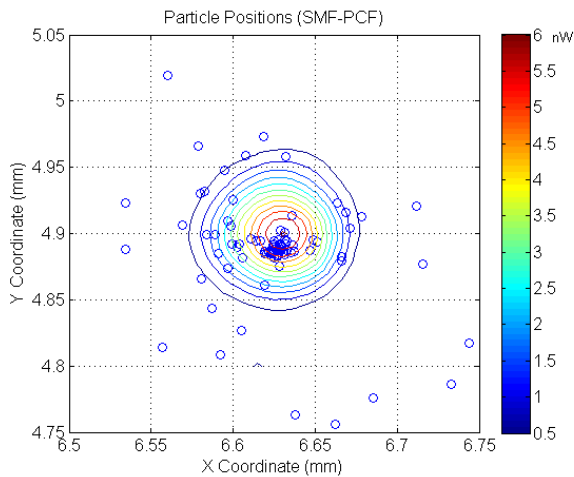
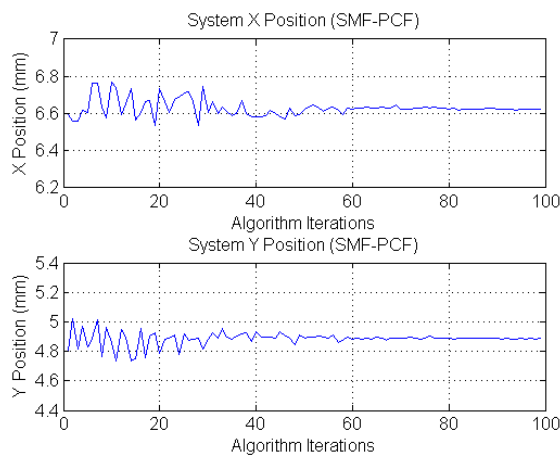

Fig. 6. Evolution of X and Y coordinates (SMF-SMF)

Fig. 7. Particle XY positions (SMF-PCF)Fig. 8. Evolution of X and Y coordinates (SMF-PCF)

VI. CONCLUSION

In this work, a new alignment system based on the particle swarm optimization technique is presented. The advantages of this system versus the others are portability and simplicity. Any user regardless of his previous experience with optical fibers coupling can use it. The experimental results presented show that the best number of particles to use that offers the lowest absolute error in relation to the best coordinates obtained and the lowest number of iterations can be determined. It is to be noted that decreasing the number of particles will reduce the number of iterations required to find the best coordinates, however if the swarm becomes too small, the algorithm could take even longer or not be able to find the best solution at all. This is a dilemma we face when choosing the size of the particle swarm. We can see that a population of 10 particles gave consistent results across all configuration given in table II. The error percentages are small and the average time is acceptable.

ACKNOWLEDGMENT

The authors would like to thank the Natural Sciences and Engineering Research Council of Canada for its financial support with this project.

REFERENCES

- [1] J. Kennedy and R. Eberhart, "Particle swarm optimization," *IEEE International Conference on Neural Networks*, pp. 1942–1948, 1995.
- [2] R. Eberhart and Y. Shi, "Comparison between genetic algorithms and particle swarm optimization. evolutionary programming vii," *Lecture Notes in Computer Science, Springer-Verlag*, pp. 661–616, 1998.
- [3] W. Yiheng, L. Liang, and G. Haibing, "Frontier-based multi-robot map exploration using particle swarm optimization," *IEEE Symposium on Swarm Intelligence*, pp. 1–6, 2011.
- [4] M. Miyatake, M. Veerachary, F. Toriumi, N. Fujii, and H. Ko, "Maximum power point tracking of multiple photovoltaic arrays: A pso approach," *IEEE Transactions on Aerospace and Electronic Systems*, pp. 367–380, 2011.
- [5] C. Shaozhong, T. Ji, and L. Heping, "Pso algorithm-based robust design of pid controller for pmsm," *Sixth International Conference on Natural Computation*, pp. 3513–3517, 2011.
- [6] J. Knight, T. Briks, J. Russell, and M. Atkin, "All-silica single-mode optical fiber with photonic crystal cladding," *Opt. Lett.* *21*, pp. 1547–1549, 1996.
- [7] Z. Wenxin, D. Duke, T. Kubo, and B. Malinsky, "Interrelation profile analysis method for alignment of polarization-maintaining fiber," *Optical Fiber Communication (OFC), collocated National Fiber Optic Engineers Conference, 2010 Conference on (OFC/NFOEC)*, pp. 1–3, 2010.
- [8] M. Shimizu, S. Takashima, and H. Kobayashi, "Identification system for optical fiber transmission operation lines with local-light injection and detection coupling system," *Lightwave Technology, Journal of*, pp. 686–692, 1994.
- [9] W. Shun and Z. Yixin, "A robust alignment algorithm for microprocessor based fiber fusion splicer," *Image and Signal Processing, 2009. CISP '09. 2nd International Congress on*, pp. 1–4, 2009.
- [10] S. Leon-Saval, T. Birks, N. Joly, A. George, W. Wadsworth, G. Kakarantzas, and P. Russell, "Splice-free interfacing of photonic crystal fibers," *Opt. Lett. Vol. 30, No. 13*, pp. 1629–1631, 2005.
- [11] P. Bennett, T. M. Monro, and D. Richardson, "Toward practical holey fiber technology: fabrication, splicing, modeling, and characterization," *Opt. Lett.* *24*, pp. 1203–1205, 1999.
- [12] F. Couny, F. Benabid, and P. Light, "Reduction of fresnel back-reflection at splice interface between hollow core pcf and single-mode fiber," *IEEE Photonics Technology Letters, Vol. 19 Iss. 13*, pp. 1020–1022, 2007.
- [13] Y. L. Tsung, "Using a two-stage optimization strategy for the active alignment of multifiber optical devices," *Opt. Eng.* *49*, 053401, 2010.
- [14] T. Lin, M. Yu, and C. Lee, "Optomechatronic integration for the optimal control system of multi-fiber active alignment," *Proc. SPIE 7266, 72661T*, 2008.
- [15] T. Y. Lin, M. Yu, and W. Liu, "Novel optomechanical alignment method using a numerical optimization methodology," *Opt. Eng.* *46*, 065004, 2007.
- [16] D. Pham and M. Castellani, "Intelligent control of fiber optic components assembly," *Proc. Inst. Mech. Eng., Part B 215*, pp. 1177–1189, 2001.
- [17] R. Zhang and F. Shi, "Novel fiber optic alignment strategy using hamiltonian algorithm and matlab/simulink," *Opt. Eng.* *42*, pp. 2240–2245, 2003.
- [18] M. Murakawa, H. Nosato, and T. Higuchi, "Automatic optical fiber alignment system using genetic algorithms," *Proc. 6th Int. Conf. on Artificial Evolution*, pp. 223–234, 2003.
- [19] —, "Automatic optical fiber alignment system using genetic algorithms," *NASA/ESA Conference on Adaptive Hardware and Systems*, 2006.