

Angle Analyzer of an Encoder using the LabVIEW

Hyun-Min Kim, Yun-Seok Lim, Hyeok-Jin Yun, Jang-Mok Kim and Hee-je Kim

Abstract—As we make progressive products for good works, and future industries want to get higher speed and resolution from various developments in the robotics as well as precise control system, the concept of control feedback is getting more important. Within a range of industrial developments, the concept is most responsible for the high reliability of a device. We explain an efficient analyzing method of a rotary encoder such as an incremental type encoder and absolute type encoder using the LabVIEW program

Keywords—LabVIEW, PFI Function, Angle analyzer, Incremental encoder, Absolute encoder

I. INTRODUCTION

THIS demand for high position control of resolution is rapidly increasing in the precision manufacturing field. Especially, in precision rotary machine (stepping and servo motor), high-precision tools, industrial robots, automate guide vehicles are the main applications. Since those machines need position sensing device and they need the rotary encoder in the field. Encoder is composed of shaft and output (converts turning angle into electrical signal), and it detects various moving motions. The rotary encoder has many tiny slits on the corner of the circular plate. Rotary and fixed slits, between a transmitter diode and receive diode, make a signal from the transmitted or blocked light. Two digital signals have a difference of 90° electric phase [2, 3].

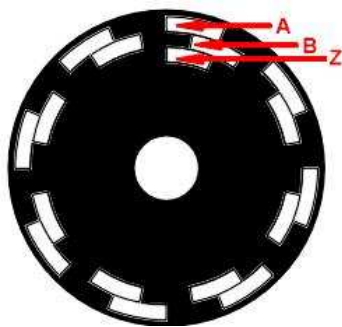

Fig. 1 Incremental rotary encoder

Hyun-Min Kim is with the Department of Robotics in Pusan National University, (phone: 82-10-4559-0130; e-mail: ccaryboy1@naver.com).

Yun-Seok Lim is with Autonics Co. (e-mail: gaedory@autonics.co.kr).

T. Hyeok-Jin Yun is with the Department of Robotics in Pusan National University, (e-mail: yhj3409@naver.com).

Jang-Mok Kim is a professor with the Department of Robotics in Pusan National University, (e-mail: jmok@pusan.ac.kr).

Hee-Je Kim is a professor with the Department of Robotics in Pusan National University, (e-mail: heeje@pusan.ac.kr).



Fig. 2 Absolute rotary encoder

II. SYSTEM DESIGN

A. Summary

We tried to find a method of efficient measurement and analysis from incremental and absolute type rotary encoder in this paper.

B. Basic Principle

Absolute rotary encoder output shows up the order signal from combinations of resolving power ($2^0 \sim 2^{12}$, maximum output is 13pcs). During the rotation, encoder applies the sampling signal of A or B phase [4].

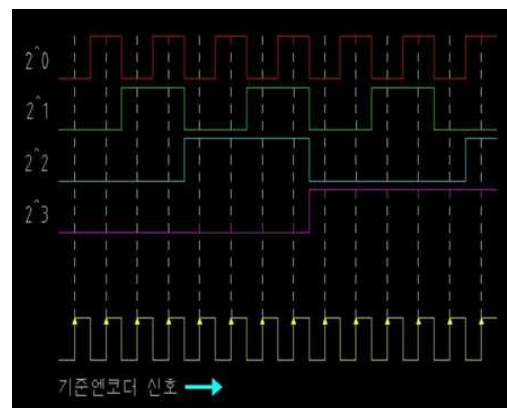

Fig. 3 Basic principle of incremental encoder

Each phase has an angle ($360/\text{Resolving power}$) about 1pulse. It calculates a number of pulse and angle. But order signal must increase to constant values, and it must be included in the settings error [1].

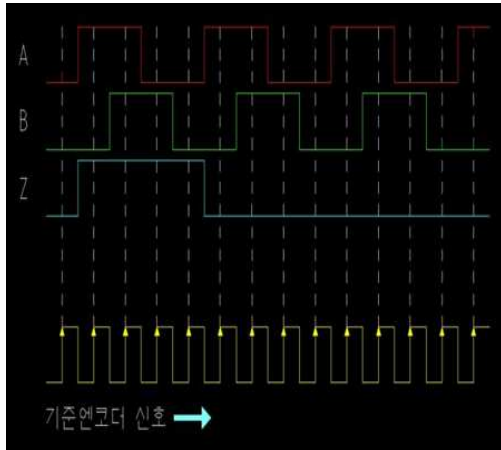

Fig. 4 Basic principle of Absolute encoder measuring

C. Experimental Equipment

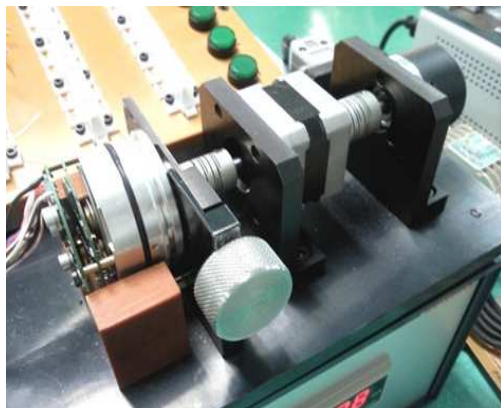

Fig. 5 Motor & encoder test equipment

TABLE I
EXPERIMENTAL COMPONENTS

Components	Product
Meter to detect voltage & current	M4Y
Motor & Motor Driver	A1K-S543W, MD5-HD14
Measuring Encoder (Absolute Type)	EP50S8-1024-3F-N
Standard Encoder ($\times 4=20000$ Resolution)	E40S-6-5000-3-N-24
5VDC Power Supply	SP-0305
12VDC Power Supply	SPA-050-12
24VDC Power Supply	SPA-050-24
AC Inlet, Fuse, A variety of Connector & Control PCB	

The motor gives rated voltage and current as output. And standard encoder makes a pre-scaling four times than input, 5000P/R to 20000P/R, each signal use twenty sampling signal. And also there are several components such as power supply

for source, PCB for receiving the output of the encoder, AC Inlet, fuse and connector [5].



Fig. 6 Internal components of interface device

Each relay decides test's power and rated voltage of the encoder. And it also connects a pull up/down resistors according to the type of output (NPN/PNP).

D. Control circuit

Each relay decides test's power and rated voltage of the encoder. And it also connects a pull up/down resistors according to the type of output (NPN/PNP).

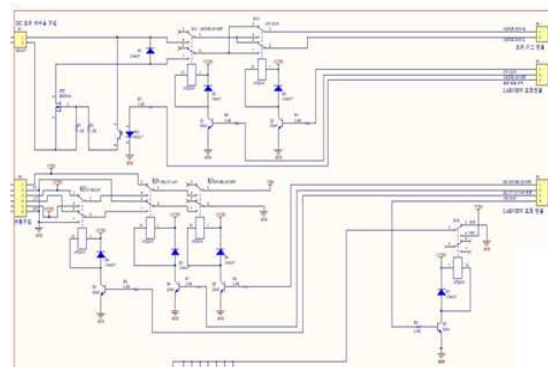

Fig. 7 A variety of relay & switching function part

E. Encoder Analyzer

Incremental encoder analyzer detects each phase (A, B, Z) of the output signal and displays the angle, duty, deviation and accumulation. Absolute encoder analyzer displays thirteen outputs (1024P/R, BCD output) of the combination of signal.



Fig. 8 Incremental encoder analyzer

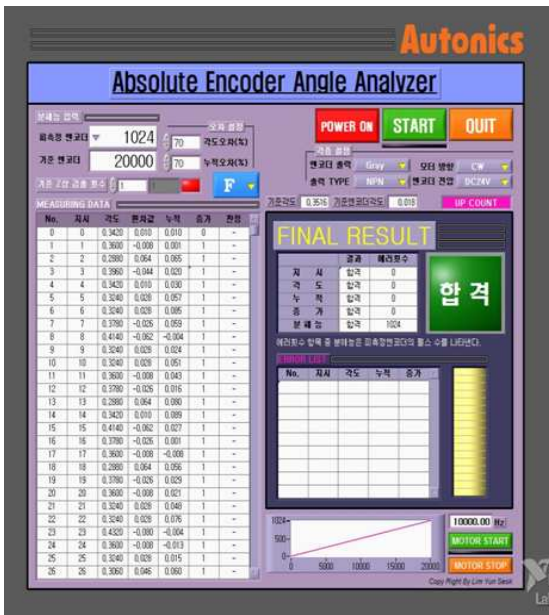

Fig. 9 Absolute encoder analyzer

There are several things such as resolving power, error (angle phase difference, duty ratio), direction of rotation (CW, CCW), source (5, 12, 24V DC), motor speed and number of Z phase detection in the setting's value. While the motor rotates, analyzer calculates the measured data and checks the distinction 'PASS or FAIL' of each phase and also displays a list of 'FAIL' and the reason [6].

F. LabVIEW Program Block Diagram

1. Motor Drive & Various Settings

The counter output function of DAQmx is used in the motor driving part. It makes a pulse about input frequency (motor

RPM is decided from the combination of frequency and resolving power of motor drive). DAQmx digital output makes a signal (ON/OFF) to interface controller that motor and encoder.

2. Real Measuring Part

Measurement of Absolute encoder is made from Z phase detection. This part decides a start point of encoder measurement. The number of Z phase detection is used as reference points.

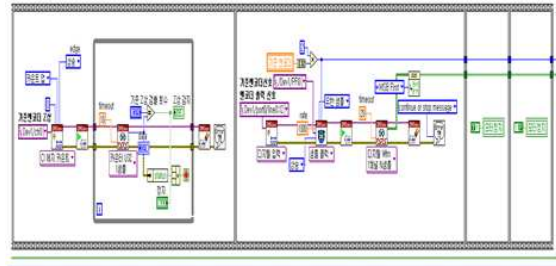

Fig. 10 Real measuring part (Absolute type)

3. Data Arrangement

According to the types of output (BCD, binary, gray), data is converted to the number of array and saved.

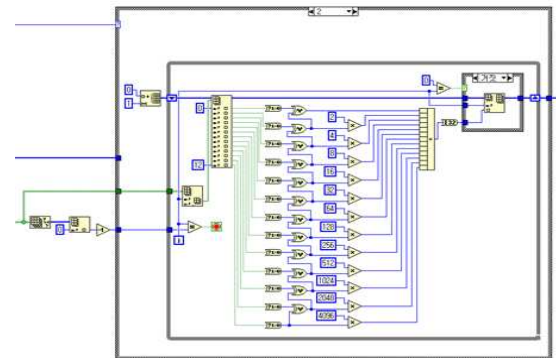

Fig. 11 Code conversion

Data arrangement converts a Boolean code to moderate code. It eliminates wrong data (very little impact signal, wrong arrangement impulse) and separates from Final analyzing part.

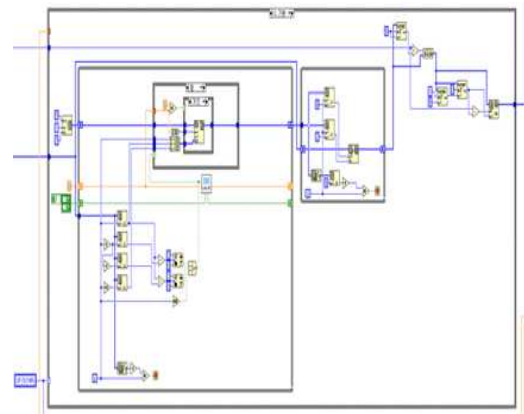

Fig. 12 Data arrangement

4. Data Analyzing

A table is generated regarding angle, deviation, accumulation and error using incremental and absolute encoder data.

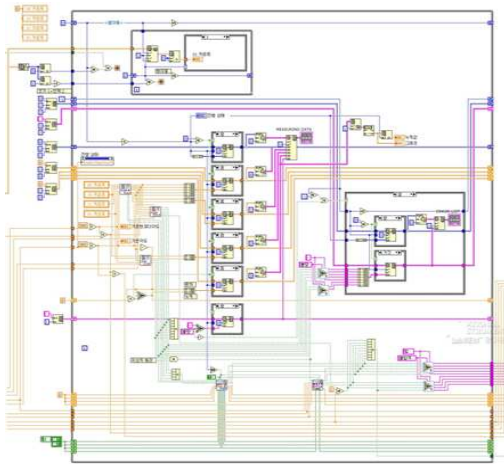

Fig. 13 Data arrangement

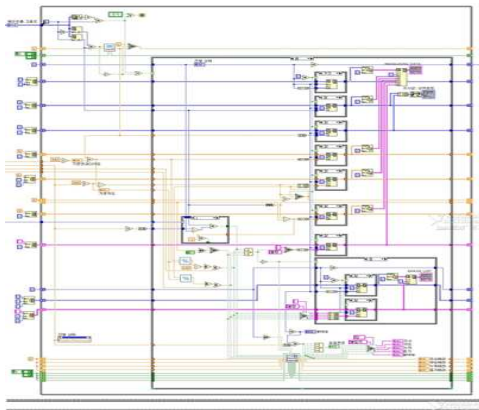

Fig. 14 Data analyzing (Absolute type)

5. Final Analyzing

It compiles an output data table from the analyzing part. This table judges the final 'PASS or FAIL' and marks the number of several errors. So, user can identify the inspected items.

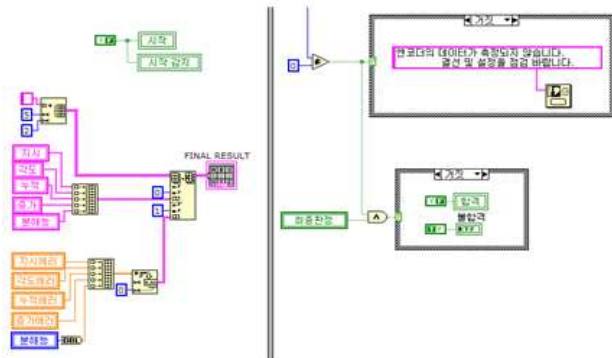

Fig. 15 Final analyzing part

III. CONCLUSION

Since complex equipment will be needed, verification field also will be changed by the professionals. In future, feedback system will be a very important factor in the control system of the robot industry. And an encoder also plays a key part in the reliability and development of the industry at the same time. It is meaningful that various industries have high accuracy encoder through the simple output control.

ACKNOWLEDGMENT

This research was supported by the MKE(The Ministry of Knowledge Economy), Korea, under the Human Resources Development Program for robotics support program supervised by the NIPA(National IT Industry Promotion Agency) (NIPA-2011-C7000-1001-0009).

REFERENCES

- [1] Y. S. LIM, "A study of angle measurement about encoder using LabVIEW", Pusan National University, 2011.
- [2] National Instruments Corporation. <http://www.ni.com>
- [3] Autonics Encoder R&D center.
- [4] David, G.A. and Michael, B.H., "Introduction to Mechatronics and Measurement System 3th Ed," McGraw Hill, pp.322-329, 2006.
- [5] J. Akedo, Y. Kato, and H. Kobayashi, "High-Precision detection method for the reference position in an optical encoder", Applied optics, vol.32, no.3, May 1993.
- [6] D. Y. Kwak, "Measuring LabVIEW and controlling of computer base", Ohm.W.-K. Chen, *Linear Networks and Systems* (Book style). Belmont, CA: Wadsworth, 1993, pp. 123-135.