

# Analysis of a PWM Boost Inverter for Solar Home Application

Rafia Akhter, and Aminul Hoque

**Abstract**—Solar Cells are destined to supply electric energy beginning from primary resources. It can charge a battery up to 12V<sub>dc</sub>. For residential use an inverter for 12V<sub>dc</sub> to 220V<sub>ac</sub> conversion is desired. For this a static DC-AC converter is necessarily inserted between the solar cells and the distribution network. This paper describes a new P.W.M. strategy for a voltage source inverter. This modulation strategy reduces the energy losses and harmonics in the P.W.M. voltage source inverter. This technique allows the P.W.M. voltage source inverter to become a new feasible solution for solar home application.

**Keywords**—Boost Inverter, inverter, duty cycle, PWM

## I. INTRODUCTION

THE solar cell transforms the light energy into electric energy. It represents a source with a good energy density and a high theoretical efficiency. From an electric point of view, the solar cell is considered as a voltage source. This source is nevertheless imperfect [1]. Therefore it is necessary to insert an inverter between the solar cell and the network in order to obtain the alternating electric source. Criteria have to be defined to choose the inverter, taking into account the difference of voltage values between a typical solar cell (12V) and the available voltage for home application is (220V AC). The classic solution for this kind of conversion is a boost regulator plus a P.W.M. voltage source inverter [2, 3]. In this paper, we study a P.W.M. voltage source inverter based on boost concept which directly converts 12V DC to 220V AC. We use a switch with three semiconductors, two diode plus an IGBT, because we need a bi-directional blocking switch. The main attribute of the new inverter topology is the fact that it generates an AC output voltage larger than the DC input, depending on the instantaneous duty – cycle [11, 12]. This property is not found in the classical voltage source inverter which produces an AC output instantaneous voltage always lower than the DC input voltage. Operation, analysis, modulation, control strategy and experimental results are included in this paper. The new inverter is intended to be used in UPS design, whenever an AC voltage larger than the DC link voltage is needed, with no need of a second power conversion stage.

Rafia Akhter, Faculty of Engineering, American International University Bangladesh, Banani, Dhaka, Bangladesh (phone: 0152448285, e-mail: rafia@aiub.edu).

Aminul Hoque, Professor, EEE, BUET, Dhaka-1000, Bangladesh (e-mail: mac@eee.buet.ac.bd).

## II. THE SOLAR CELL

Solar cells, also called photovoltaic or PV cells, change sunlight directly to electricity. When sunlight strikes the solar cell, electrons are knocked loose. They move toward the treated front surface. An electron imbalance is created between the front and back. When the two surfaces are joined by a connector like a wire, a current of electricity travels between the negative and positive sides. Solar energy can be used to heat our homes, heat water, cook our food, and power our lights. Solar cells are used to power calculators and watches as well as lights, refrigerators, and even cars [8]. A typical silicon PV cell is composed of a thin wafer consisting of an ultra-thin layer of phosphorus-doped (N-type) silicon on top of a thicker layer of boron-doped (P-type) silicon. An electrical field is created near the top surface of the cell where these two materials are in contact, called the P-N junction. When sunlight strikes the surface of a PV cell, this electrical field provides momentum and direction to light-stimulated electrons, resulting in a flow of current when the solar cell is connected to an electrical load. Regardless of size, a typical silicon PV cell produces about 0.5 – 0.6 volt DC under open-circuit, no-load conditions. The current (and power) output of a PV cell depends on its efficiency and size (surface area), and is proportional the intensity of sunlight striking the surface of the cell.

### A. Photovoltaic System

Photovoltaic is the art of converting sunlight directly into electricity using solar cells. A silicon solar cell is a diode formed by joining p-type (typically boron doped) and n-type

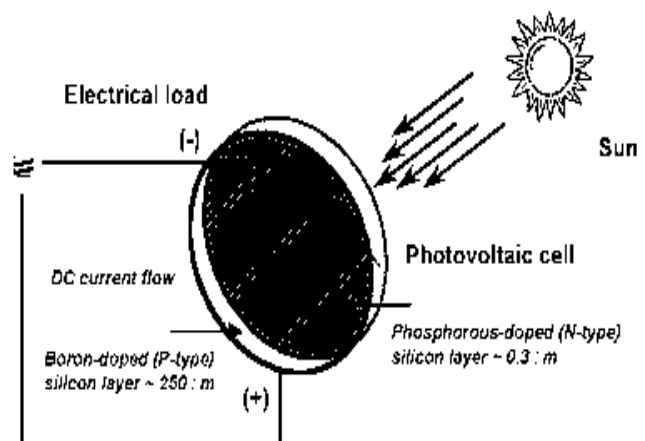

Fig. 1 Diagram of a photovoltaic cell

(typically phosphorous doped) silicon. Light shining on such a cell can behave in a number of ways as illustrated in Fig. 1 and the behavior of light shining on solar cell is shown in Fig. 2. It has six properties. To maximize the power rating of a solar cell, it must be designed so as to maximize desired absorption (3) and absorption after reflection (5).

The behavior of light shining on solar cell contains six properties:

1. Reflection and absorption at top contact;
2. Reflection at cell surface;
3. Desired absorption;
4. Reflection from rear out of cell-weakly absorbed light only;
5. Absorption after reflection;
6. Absorption in rear contact.

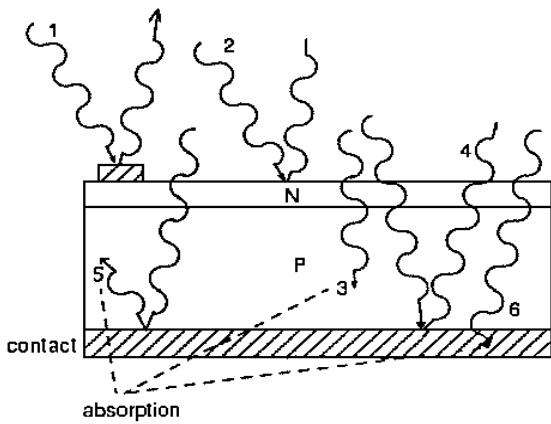

Fig. 2 Behavior of light shining on solar cell

**B. PV Cell Interconnection and Module Design**

Solar cells are rarely used individually. Rather, cells with similar characteristics are connected and encapsulated to form modules (arrays) which, in turn, are the basic building blocks of solar arrays. Usually about 36 cells are used for a nominal 12 V charging system.

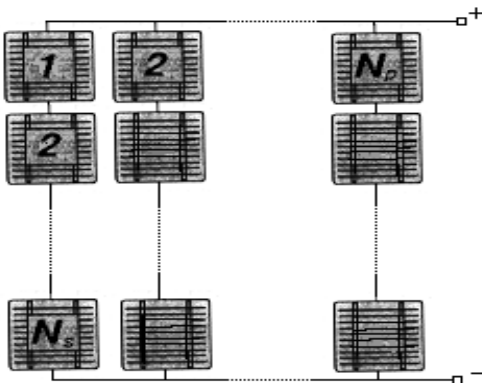

Fig. 3 Cells in series and in parallel

**III. THE BOOST INVERTER TOPOLOGY**

The conventional VSI (voltage source inverter) shown in Fig. 3, referred to as buck inverter in this paper, is probably the most important power converter topology. It is used in many distinct industrial and commercial applications. Among these applications, UPS and AC motor drives are the most important. One of the characteristics of the buck inverter is that the instantaneous average output voltage is always lower than the input DC voltage. As a consequence, when an output voltage larger than the input one is needed, a boost converter must be used between the DC source and the inverter, shown in Fig. 4

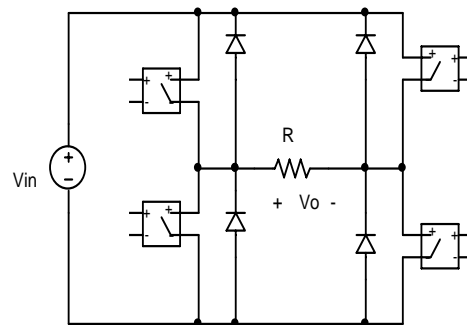

Fig. 4 The conventional Voltage source inverter or buck inverter

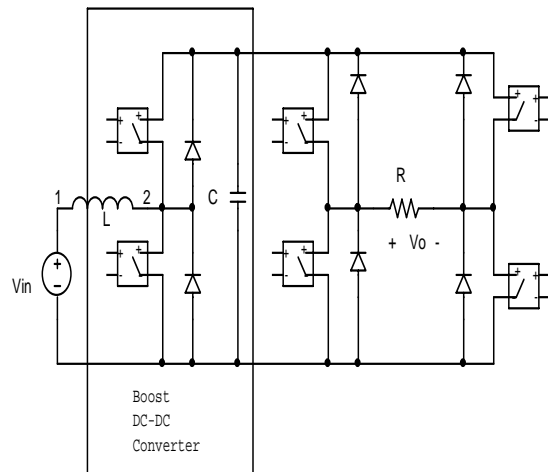

Fig. 5 Circuit used to generate an AC voltage larger than DC input voltage

Depending on the power and voltage levels involved, this solution can result in high volume, weight, cost and reduced efficiency. In this paper a new voltage source inverter is proposed, referred to as boost inverter, which naturally generates an output AC voltage lower or larger than the input DC voltage depending on the duty cycle. Details on analysis, control and experimentation are presented in the subsequent sections [4, 9 and 10].

IV. PRINCIPLE AND OPERATION OF BOOST INVERTER

The proposed boost inverter achieves dc to ac conversion, as indicated in Fig. 6. The blocks A and B represent DC to DC converters. These converters produce a DC - biased sine wave output, so that each source only produces a unipolar voltage. The modulation of each converter is 180 degrees out of phase with the other, which maximizes the voltage excursion across the load. The load is connected differentially across the converters. The problem of generating bipolar voltage at converters realization need to be current bi-directional. [4]. The proposed inverter is based on the boost converter. The current bi-directional boost converter is shown in Fig. 7(a). A circuit implementation of the boost DC to AC converter is shown in Fig. 7(b).

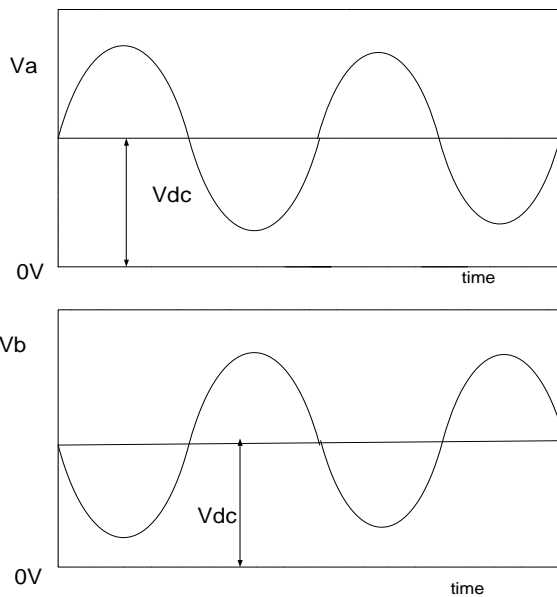
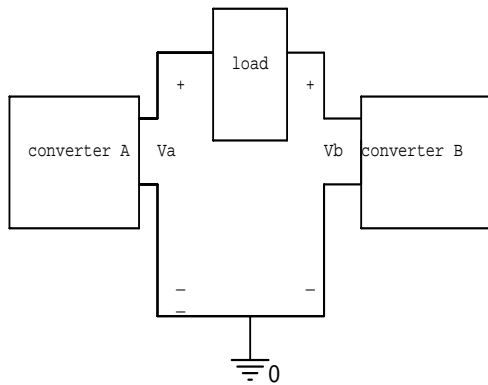

Fig. 6 A basic approach to achieve DC-to-AC conversion, with boost characteristics

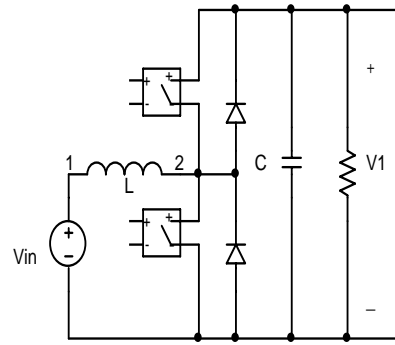

Fig. 7 (a)

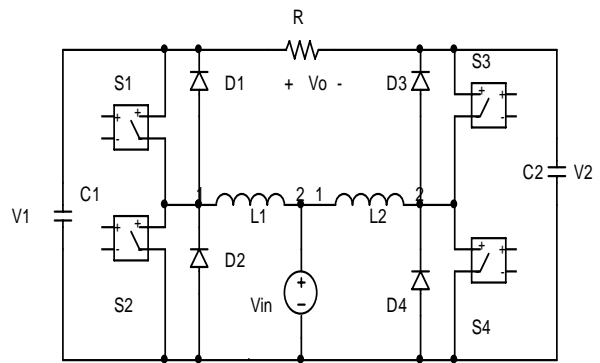

Fig. 7 (b)

Fig. 7 (a) The current bi-directional boost converter and (b) The proposed DC-AC boost converter

For a boost converter, by using the averaging concept, we obtain the following voltage relation for the continuous conduction mode:

$$\frac{V_1}{V_{in}} = \frac{1}{1 - D}$$

where D is the duty cycle.

The voltage gain, for the boost inverter, can be derived as follows. Assume that the two converters are 180 degrees out of phase. Then, the output voltage can be obtained as:

$$V_o = V_1 - V_2 = \frac{V_{in}}{1 - D} - \frac{V_{in}}{D}$$

$$\frac{V_o}{V_{in}} = \frac{2D - 1}{D(1 - D)}$$

From the gain characteristic of the boost inverter, it is interesting to note that the feature of zero output voltage is

obtained for  $D = 0.5$ . If the duty cycle is varied around this point, then there will be an AC output voltage across the output terminal.

V. DESCRIPTION OF THE CIRCUIT

Fig. 8 shows the conversion structure proposed in this paper. It consists of the cascade connection of two stages. The first stage is a boost-regulator and the second stage is the boost inverter. Fig. 9 shows the equivalent circuit of the boost inverter. It has two modes of operations.

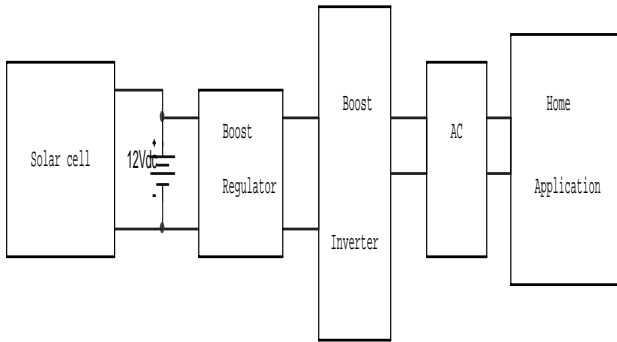

Fig. 8 Conversion of solar cell to home application

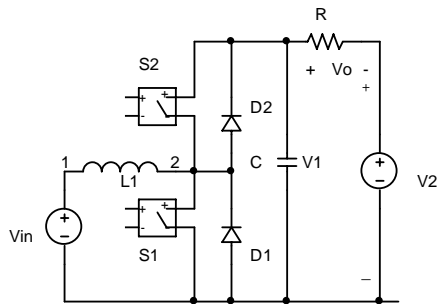

Fig. 9 Equivalent circuit for the boost inverter

Mode 1: When the switch  $S_1$  is closed and  $S_2$  is open current  $i_{L1}$  rises quite linearly, diode  $D_2$  is reverse polarized, capacitor  $C_1$  supplies energy to the output stage, and voltage  $V_1$  decreases.

Mode 2: Once the switch  $S_1$  is open and  $S_2$  is closed, current  $i_{L1}$  flows through capacitor and the output stage. The current  $i_{L1}$  decreases while capacitor  $C_1$  is recharged.

VI. SIMULATION OF THE CIRCUIT

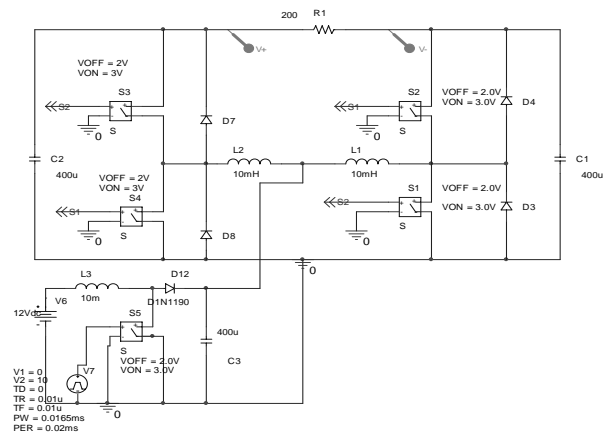

Fig. 10 (a)

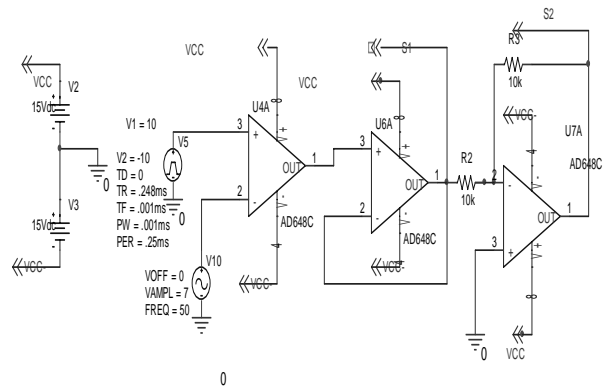

Fig. 10 (b)

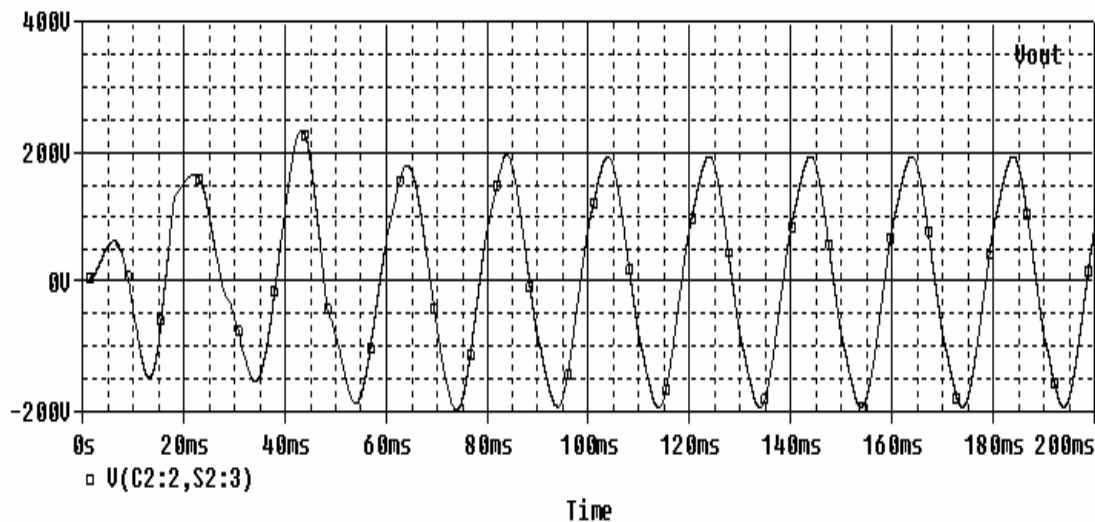

Fig. 10 (c)

Fig. 10 (a) Boost Inverter using boost regulator as DC input, (b) gate signal in circuit and (c) AC wave shape

## VII. CONCLUSION

This paper presents a new type of DC - AC converter, referred to as boost inverter. The active switches (IGBT's) are operated at a fixed frequency with the duty cycle around 50 %, which allows the use of a simple gate drive. The circuit operation has been described and discussed. The effects are verified experimentally on a 270 W - 20 kHz breadboard. The new inverter is applicable in UPS design, whenever a AC voltage larger than the DC link voltage is needed, with no need of a second power conversion stage. This circuit arrangement is better for solar cell to home application.

## REFERENCES

- [1] C. Rivas, A. Rufer. P.W.M. Current converter for electric energy production systems from fuel-cells, EPF 2000.
- [2] N. Mohan, T.M. Undeland, W.P. Robbins. Power electronics: Converters, applications and design, John Wiley & Sons, US-New York, 1995.
- [3] Vazquez N, Almazan J, Alvarez J, Aguilar C, Arau J. Analysis and experimental study of the buck, boost and buck-boost inverters [J]. Power Electronics, 2: 801 – 806, 1999.
- [4] Muhammad H.Rashid, Power Electronics, Circuits, Devices, and application-Third Edition. , Prentice-Hall of India, 2004.
- [5] F. Barzegar and S. Cuk, "Solid-state drives for induction motors: Early technology to current research," in Proc. IEEE Region 6 Conf., Anaheim, CA, Feb. 15–18, 1982.
- [6] "A new switched-mode amplifier produces clean three-phase power," in Proc. Powercon 9, 9th Int. Solid-State Power Electronics Conf., Washington, DC, July 13–15, 1982.
- [7] Photovoltaic Panel Simulation User's Guide, 2004.
- [8] V. Vorperian, "Simplified Analysis of PWM Converters Using the Model of the PWM Switch Part I: Continuous Conduction", Proceeding of the VPEC seminar, Blacksburg, VA, pp 1-9, 1989.
- [9] R. Tymerski, V. Vorperian, F.C. Lee and W. Baumann "Nonlinear Modeling of the PWM Switch" IEEE Power Electronics Specialists Conference, pp 968 -976 1988.
- [10] Orosco R, Vazquez N. Discrete sliding mode control for DC/DC converters. Power Electronics Congress [J],pp: 231–236, 2000.
- [11] Ram'on O. C'aceres," A Boost DC–AC Converter: Analysis, Design, and Experimentation", IEEE Transactions on Power Electronics, Vol. 14, No. 1, January 1999.
- [12] Control and Experimentation," in Proc. Int. Conf. Industrial Electronics, Control and Instrumentation (IECON'95), pp. 546–551, Nov. 1995.