

# Advantages of a New Manufacturing Facility for the Production of Nanofiber

R. Knizek, D. Karhankova

**Abstract**—The production of nanofibers and the machinery for their production is a current issue. The pioneer, in the industrial production of nanofibers, is the machinery with the sales descriptions Nanospider™ from the company Elmarco, which came into being in 2008. Most of the production facilities, like Nanospider™, use electrospinning. There are also other methods of industrial production of nanofibers, such as the centrifugal spinning process, which is used by FibeRio Technology Corporation. However, each method and machine has its advantages, but also disadvantages and that is the reason why a new machine called as Nanomachine, which eliminates the disadvantages of other production facilities producing nanofibers, has been developed.

**Keywords**—Nanomachine, nanospider, spinning slat, electrospinning.

## I. INTRODUCTION

NOWADAYS, there are numerous production facilities for the production of nanofibers. The pioneer in industrial production of nanofibers certainly is the machinery Nanospider™ (Fig. 1), made by the Czech company Elmarco and developed by Prof. Oldrich Jirsak at the Technical University of Liberec.

Another Czech company which also uses the electrospinning as Nanospider™ is SPUR. On the contrary, a completely different method for producing nanofibers, the centrifugal spinning, is used by FibeRio Technology Corporation. The above mentioned companies are engaged in manufacturing machinery for the production of nanofibers. This is a breakdown according to the main spinning units:

- 1) Electrospinning: nozzle (Spur), roller (Elmarco), string (Elmarco)
- 2) Forcespinning (FibeRio Technology Corporation)

## II. METHOD OF PRODUCING NANOFIBERS

### A. Electrospinning

Electrospinning is a method of producing nanofibers. The first patent of this principle comes already from 1902 by JF Cooley of the University of Boston. This method, for its low energy consumption and high production of nanofibers, is suitable for industrial use. One of the advantages includes the possibility to use naturally decomposable materials [1], [2].

The electrospinning process occurs when the electrical forces at the surface of a polymer solution overcome the

surface tension and cause an electrically charged jet to be ejected [3], [4]. Then, the Taylor cone (Fig. 2) is formed and it leads to the expulsion of the stream of electrically charged polymer liquid.

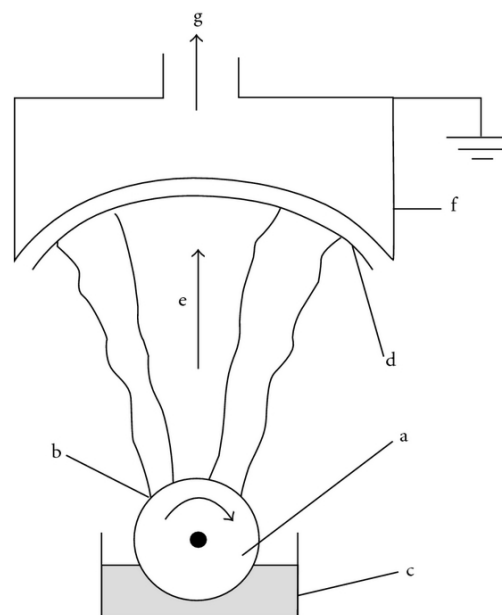

Fig. 1 Nanospider™ equipment for production of nanofibers by electrostatic spinning: (a) electrode metal roller as positive electrode, (b) fiber-forming polymer layer, (c) reservoir of polymer solution, (d) textile substrate (supportive material), (e) fiber formation direction, (f) electrode earthing shield, (g) air suction [10]



Fig. 2 Taylor cone

The solvent evaporates as the jet travels in the air, leaving behind charged polymer fibers that lay themselves randomly on a collecting metallic electrode [8]. During this phase, the polymer stream is gradually very strained, and ultrafine fibers are formed [5]-[7], [9].

It is well known that the morphology of the resulting fibers is determined by a synergetic effect of solution parameters and electrostatic forces. These parameters include viscosity,

R. Knizek and D. Karhankova are with the Technical University of Liberec, Faculty of Textile Engineering, Department of Textile Evaluation, Studentska 2, 461 17 Liberec, Czech Republic (e-mail: roman.knizek@tul.cz, denisa.karhankova@tul.cz).

surface tension, concentration and dielectric properties of the spinning solution and process parameters such as the feed rate of the solution to the tip and acceleration voltage. Also, ambient parameters including temperature, humidity and air velocity in the electrospinning chamber influence the results [10], [11].

Here, we provide a short review of the newest development on the scale-up of nanofiber production by electrospinning, with primary focus on multi-needle and needleless electrospinning. Schematic diagrams of electrospinning setups for nanofiber mass production are presented below [12].

### B. Electroblowing

The electro-blowing process combines electrostatic spinning while blowing air. It includes applying a high voltage to the electrode and grounding the spinneret such that an electric field is generated between the spinneret and the

electrode of sufficient strength to impart an electrical charge on the polymer as it issues from the spinning nozzle [16]. For example, Kim et al. designed an electrospinning spinneret with an air nozzle to produce nanofiber webs from thermoplastic or thermosetting polymers [14]. A subsequent patent by Bryner et al. improved the electroblowing process by directly applying the voltage to a pair of electrodes located parallel to the surface of a grounded spinneret, which overcame those disadvantages caused by the conventional voltage application method [15].

### C. SPUR-Line Spinning

The Czech company SPUR a.s. can be an example of the industrial production from the nozzle which is the most widespread method of producing nanofibers. The facility uses the following spinning methods (Fig. 3): electrostatic spinning, melt spinning, and electro-blowing [13].

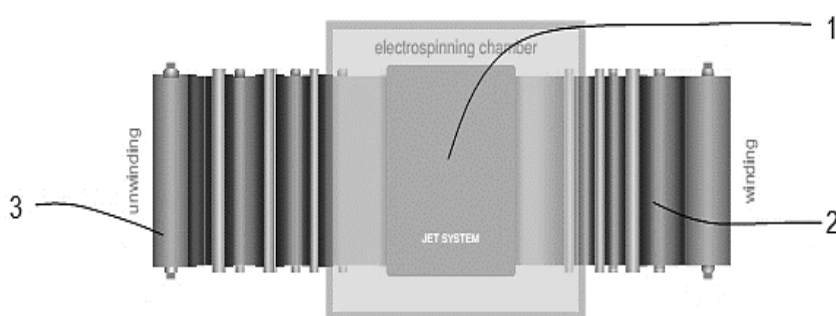

Fig. 3 SPUR-line Spinning process: (1) spinning space, (2) winding, (3) unwinding [13]

### D. Spinning out of "Cylinder" - Principle of Nanospider™ First Generation Technology

Unlike the other previous methods, Nanospider™ does not use any nozzle or capillary tube for the production of nanofibers, it uses a cylinder. The cylinder is partially immersed in the polymer liquid (Fig. 4), and as it rotates, it is applying to itself a certain quantity of polymer liquid. At the top of the cylinder, the Taylor cone is formed - that is the beginning of the nanofiber formation. Taylor cones are formed close to each other along the whole length of the cylinder, which provides a high production capacity of the spinning head of the Nanospider™. The currents of polymer liquid are then, by evaporating the solvent, transformed and they become nanofibers before they reach the opposite collecting electrodes [16].

The advantage of the method is that it enables spinning in the industrial width, which is 1.6 [17].

### E. Forcespinning

It is a continual production of nanofibers. This method is used by the company FibeRio; the machine is called FiberLab.Po. At forcespinning, the power of centrifugal force is applied. The machine can work with liquids or pure melt materials. Another advantage is that it is not necessary to use a heated air nozzle so the process is cheaper than the meltblown method. The machine uses a high speed spinneret, which is

simultaneously heated, is presented in Fig. 5. During the heating, the polymer is melted and extruded by centrifugal force through the nozzle of the spinneret. High rotations lengthen the fiber and get it thinner [18].

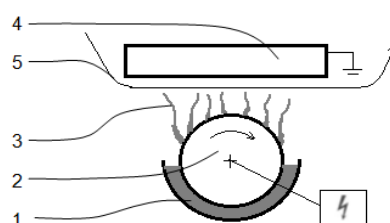

Fig. 4 Nanospider™ machine: (1) polymer or melt liquid, (2) cylinder, high-voltage source, (3) emerging nanofibers, (4) grounded collector, catching nanofibers, (5) supportlayer for nanofibers [4]

The resulting nanofiber is then taken down by a fiber catcher. The thermal energy is combined here with the centrifugal force. The advantage is that we get a long thread, and the disadvantage is high energy demands of the production [19].

### F. Advantages and Disadvantages of These Technologies

Currently, on industrial scale, due to its very low dispersion and uniformity of nanofibers, the most advantageous technology is electrostatic spinning without nozzle, where the

nanofibers from polymer liquid or of its melt are produced by using the force effect of the high electric field. It has been mentioned above in the individual technologies. Therefore, here is the possibility to use spinning electrodes of suitable shape to increase the effectiveness and efficiency of production, but even those have their drawbacks. The cylinder, which rotates slowly and is wading in the polymer liquid, has the advantage of its mechanical simplicity, but its biggest drawback is the insufficient mixing of the liquid. The liquid thus thickens and it is more prone to chemical degradation. Thus, it causes a reduction of the output. This problem was resolved by using strings as spinning means. However, at this method, it is difficult to set the dosage of the polymer liquid,

which can dry out on the machine parts, and which must be thoroughly cleaned. There is one disadvantage with string spinning: the dosing device which is between the string and the collecting electrode causes unevenness of the nanofiber layer. Another disadvantage, at both the string and the cylinder device, is poorly fixed air conditioning system, which at the beginning has other parameters than at the end of the machine, which also affects the uniformity of the nanofiber layer. At the nozzle device, the nozzle itself is again a disadvantage. If there are more nozzles side by side, there is an interaction of these jets during spinning, and thus the great unevenness, especially at higher basis weights of the nanofiber layer.

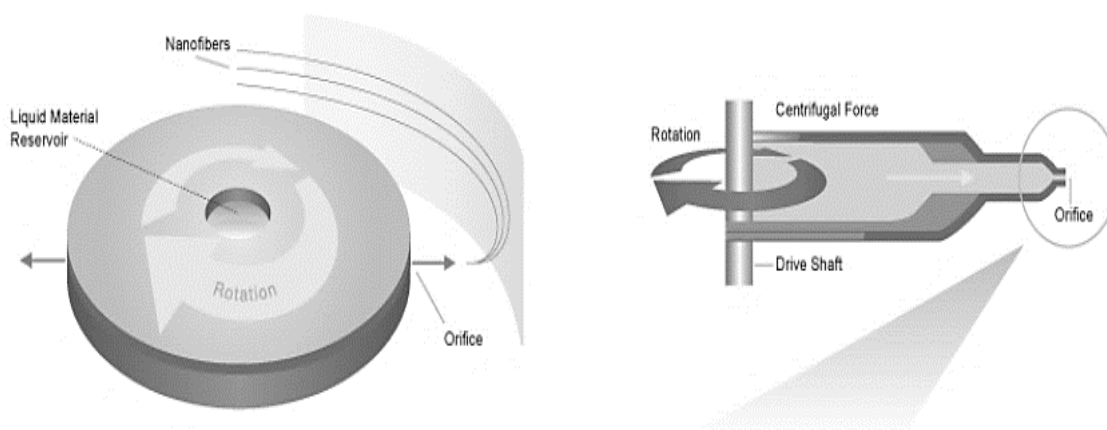

Fig. 5 Forcespinning process [19]

Forcespinning operates on a different principle, therefore, this process does not cause the above problems. Nevertheless, its biggest disadvantage is a very poor dispersion diameter of nanofibers and the bulkiness is too large, which may be undesirable in some cases. Next chapter is devoted to Nanomachine which works on a similar principle as Nanospider™ that is on the basis of electrospinning, but with the effort to eliminate or even remove the above mentioned disadvantages.

### III. EXPERIMENT

#### A. Innovative Method and Device

We proposed a method for production of nanofibers through electrostatic spinning of solution or melt, which aims to remove disadvantages of the prior art and apparatus for manufacture. Nanomachine is based on the principle of electrospinning.

The principle of spinning is based on a patented spinning slat which can be in the width from 200 mm to 1600 mm.

Polymer solutions or melts:

- a) Organic polymers,
- b) Inorganic polymers.

#### B. The Principle of Nanomachine

As it has already been mentioned, the main principle of Nanomachine is based on the patented stainless steel spinning

slats. The principle can be seen on Fig. 6.

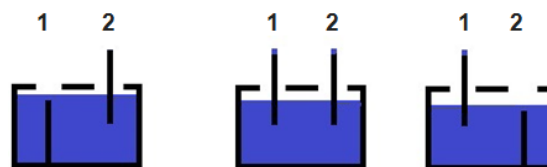

Fig. 6 Nanomachine principle

Slat 1 is immersed in a bath of polymer. Slat 2 is above the surface of the bath with the polymer on which spinning (creating nanofiber layer) is carried out. Slat 1 moves out of the bath and a thin layer of polymer gets stuck on the surface of the slat. Slat 1 is at the same level as Slat 2 which is moving below the surface of the polymer. This process is repeated over and over again.

The advantage of the slats is that, by moving, they constantly mix the polymer, in addition the bath is constantly fed with polymer and the excess polymer flows back to the supply tank. It is the same principle as a pool of water, so that the water, in our case the polymer did not go wrong.

The edge of the spinning slat is provided with side openings for easy manipulation (insertion, removal and cleansing). Based on studies of electrostatic spinning, we used slat with straight edge because the polymer is apply evenly.

Solvent recovery in large-scale electrospinning is a crucial issue, which has limited the industrialization of this technology. This instrument enables a constant level of the solution or melt in the reservoir because it has the overflow. A schematic of the new system of device is shown in Fig. 7 (sketch).

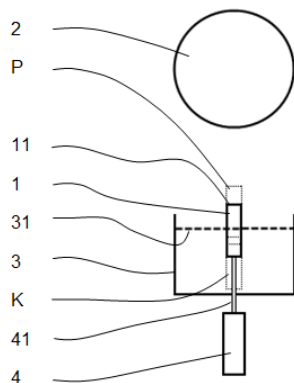

Fig. 7 Cross section of the device: (1) spinning means, (2) collection electrode, (3) reservoir for polymer, (4) double-acting pneumatic motor, (11) edge of the spinning slat, (31) polymer solution or melt liquid, (41) motion mechanism, (P) working position, (K) resting position

Herein, the illustrated example has shown that electrospinning (Nanomachine) can be a promising technology for the mass production of continuous polymeric nanofibers.

Another variant system has been designed such as the one presented in Fig. 8, where a polymer is continuously fed into two separate containers.

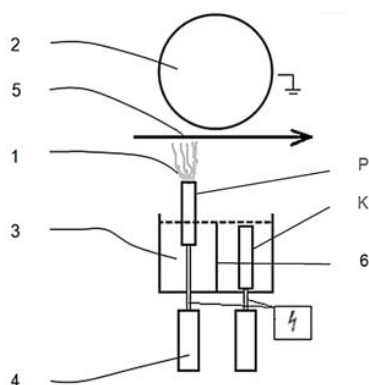

Fig. 8 Schematic diagram of Nanomachine: (1) emerging nanofibers, (2) collection electrode, (3) two reservoirs for polymer solution, (4) double-acting pneumatic motor, (5) substrate material for nanofibers, (6) partition, (P) working position, (K) resting position

Simple illustrations of prototype Nanospider™ is shown in Fig. 9. Main components of the system are the spinning system - spinning slats, collection devices, acid-resistant fan, control system, motor and brake.

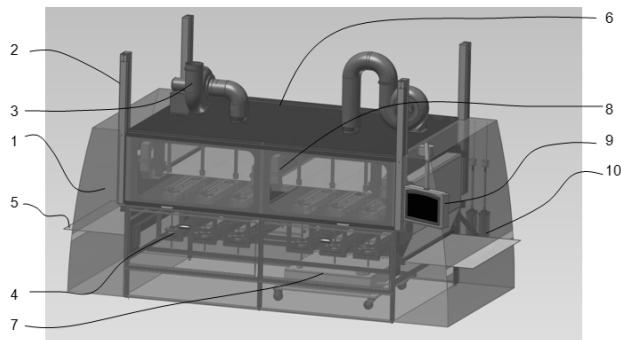

Fig. 9 Nanomachine: (1) protective cover, (2) machine frame, (3) acid-resistant fan, (4) spinning head, (5) substrate material for nanofibers, (6) spinning space, (7) distribution polymer, (8) ventilation, (9) control panel, (10) discharge wedge

The control system drives the system to the speed and temperature set-points specified by the user. The controller is also interfaced with a computer that allows the user to remotely control the process.

#### IV. CONCLUSION

A big advantage of this method is the unique air distribution, thanks to which perfect weather conditions throughout the spinning space are achieved. The temperature and relative humidity are the same at the input and the output of the Nanomachine. The biggest advantage of the Nanomachine line is the homogeneity of the nanofiber layer as there is no obstacle between the slat and the underlying material that would increase the inhomogeneity of the nanofiber layer. Additionally, along the entire length of the spinning slat nanofibers are created and they are not affected during spinning as they are at jet or other methods.

#### ACKNOWLEDGMENT

The research has been supported by the Department of Textile Evaluation, Technical University of Liberec.

#### REFERENCES

- [1] J. J. Feng, The stretching of an electrified non-Newtonian jet: a model for electrospinning, *Physics of Fluids*, vol. 14, no. 11, pp. 3912–3926, 2002.
- [2] X. Zong, K. Kim, D. Fang, S. Ran, B. S. Hsiao, B. Chu, Structure and process relationship of electrospun bioabsorbable nanofiber membranes, *Polymer*, vol. 43, no. 16, pp. 4403–4412, 2002.
- [3] W.-E. Teo, R. Inai, S. Ramakrishna, Technological advances in electrospinning of nanofibers, *Science and Technology of Advanced Materials*, vol. 12, no. 1, pp. 1–19, 2011.
- [4] O. Jirsak, F. Sanetrik, D. Lukas, V. Kotek, L. Martinova, J. Chaloupek, A Method of Nanofibres Production From a Polymer Solution Using Electrostatic Spinning and a Device for Carrying Out the Method. EP 1673493, 2006.
- [5] TUL: Method of production of nanofibers from polymer solution by electrostatic spinning and equipment to perform the way CZ Patent 294,274, 2003-2421, 2013.
- [6] O. Jirsak, F. Sanetrik, D. Lukas, V. Kotek, L. Martinova, J. Chaloupek, A method of nanofibres production from a polymer solution using electrostatic spinning and a device for carrying out the method, *European patent: ep 1 673 493*, 2004.

- [7] R. Knizek, L. Fridrichova, V. Bajzik, Polyurethane coating on a supporting layer of polymeric nanofibers, *Advanced Materials Research*, 607, 31-35, ISSN: 10226680, 2013.
- [8] K. Sarkar, C. Gomez, S. Zambrano, M. Ramirez, E. de Hoyos, H. Vasquez, K. Lozano, Electrospinning to Forcespinning, *Materials Today*, vol. 13, no. 11, pp. 12-14, 2010.
- [9] A. Frenot, I. S. Chronakis, Polymer nanofibers assembled by electrospinning, *Current Opinion in Colloid and Interface Science*, vol. 8, no. 1, pp. 64-75, 2003.
- [10] D. H. Reneker, A. L. Yarin, H. Fong, S. Koombhongse, Bending Instability of Electrically charged liquid jets of polymer solutions in electrospinning, *Journal of Applied Physics*, vol. 87, no. 9, pp. 4531-4547, 2000.
- [11] A. Greiner, J. H. Wendorff, Electrospinning: A Fascinating Method for the Preparation of Ultrathin Fibers, *Angewandte Chemie*, vol. 46, pp. 5670 - 5703, 2007.
- [12] F.-L. Zhou, R.-H. Gong, I. Porat, Mass production of nanofibre assemblies by electrostatic spinning, *Society of Chemical Industry*, vol. 58, pp. 331-342, 2009.
- [13] SPUR a.s., SPIN Line - SPUR Nanotechnologies, Technology, pp. 1-2, 2015.
- [14] Y. M. Kim, Y. B. Sung, R. Sang, K. R. Ahn, *KR Patent WO03080905*, 2003.
- [15] M. A. Bryner, J. E. Armantrout, B. S. Johnson, *US Patent 20060138710*, 2006.
- [16] S. H. Park, C. Kim, Y. O. Choi, K. S. Yang, Preparations of pitch-based CF/ACF webs by electrospinning, *Carbon*, vol. 41, no. 13, pp. 2655-2657, 2003.
- [17] Y. N. Xia, P. D. Yang, Y. G. Sun, Y. Y. B. Wu, B. Mayers, B. Gates, Y. D. Yin, F. Kim, Y. Q. Yan, One-dimensional nanostructures: synthesis, characterization, and applications, *Advanced Materials*, vol. 15, pp. 353-389, 2003.
- [18] Fieberio, Total Nanofiber Solutions Company FibeRio® Launches The Fiber Engine® FX Series Systems with 10X Increase in Output, *NEWS & EVENTS*, April 8, 2015.
- [19] B. Raghavan, H. Soto, K. Lozano, Fabrication of Melt Spun Polypropylene Nanofibers by Forcespinning, *Journal of Engineered Fibers and Fabrics*, vol. 8, no. 1, pp. 52 - 60, 2013.