

Adsorptive Waste Heat Based Air-Conditioning Control Strategy for Automotives

Indrasen Raghupatruni, Michael Glora, Ralf Diekmann, Thomas Demmer

Abstract—As the trend in automotive technology is fast moving towards hybridization and electrification to curb emissions as well as to improve the fuel efficiency, air-conditioning systems in passenger cars have not caught up with this trend and still remain as the major energy consumers amongst others. Adsorption based air-conditioning systems, e.g. with silica-gel water pair, which are already in use for residential and commercial applications, are now being considered as a technology leap once proven feasible for the passenger cars. In this paper we discuss a methodology, challenges and feasibility of implementing an adsorption based air-conditioning system in a passenger car utilizing the exhaust waste heat. We also propose an optimized control strategy with interfaces to the engine control unit of the vehicle for operating this system with reasonable efficiency supported by our simulation and validation results in a prototype vehicle, additionally comparing to existing implementations, simulation based as well as experimental. Finally we discuss the influence of start-stop and hybrid systems on the operation strategy of the adsorption air-conditioning system.

Keywords—Adsorption air-conditioning, feasibility study, optimized control strategy, prototype vehicle.

I. INTRODUCTION

AIR-Conditioning systems in automotives have long existed and evolved over a period of time. These systems have become efficient in terms of energy consumption and cooling power, but have not been successful in harnessing the waste heat generated by the ICE which accounts to approximately two-thirds of the total output power generated. Also the vehicles equipped with features such as start-stop, coasting, e-clutch, vehicles with hybrid drive train etc. aimed at reducing fuel consumption are significantly affected by the usage of these conventional automotive air-conditioning systems. Farrington R and Rugh J [1] discussed in detail the impact of vehicle air-conditioning system on fuel economy, tail-pipe emissions and the electric vehicle range.

Adsorption air-conditioning systems for automotives promise fuel savings & reduced emissions by eliminating the need for mechanically driven or electrically actuated compressors, effectively utilize the exhaust heat and can be used for cold storage i.e. by desorbing and preparing the system when there is no cooling request and engine is running during the normal driving cycle. HVAC systems demand a

high energy consumption during the initial start of the vehicle as discussed by [2] as well as during start of the vehicle when it is exposed to sun for a long time during parking as observed by [3]. This energy consumption is reduced by utilizing the cold storage property of the adsorption air-conditioning systems.

While the adsorption based air conditioning technology is prevalent in industrial and residential sector since long time, it is commercially still not available in the automotives. This technology has been experimented and analyzed in various vehicles; for example, [4] illustrated the implementation of adsorption air-condition system in a passenger car and a truck. Yongfang Zhong, Tiegang Fang and Kevin L. Wert [5] discussed a proposal and various implementations of adsorption air-conditioning systems in heavy-duty vehicles. Salvador M. Aceves [6] analyzed the applicability of adsorption system to provide air-conditioning in electric vehicles. Zhang, L. Z. [7] demonstrated the feasibility of using an adsorption cooling system driven by waste heat from a small diesel engine. Vicatos G, Gryzagoridis J, Wang S [8] illustrated implementation of a car air-conditioning system based on an absorption refrigeration cycle using energy from exhaust gas of an internal combustion engine in Nissan 1400 truck. Deshpande A C, Pillai R M [10] implemented an Adsorption Air Conditioning (AdAC) system with silica-gel water pair in a four stroke four cylinder engine. These implementations prove the applicability of adsorption systems in automotives but at the same time indicate the limitations in commercializing the concept due to various constraints as observed in this paper.

Two bed adsorption chillers with separate evaporator and condenser chambers [5], [9], [12]-[14] (Type-I) are the most commonly implemented systems compared to two bed adsorption chillers with unified condenser and evaporation chambers (Type-II). The goal of present study is to illustrate the implementation of a Type-II adsorption chiller prototype in a passenger car with a gasoline engine but not to validate our simulation model with the prototype implementation. We discuss the challenges involved during the implementation and testing phases, such as size of the system, limitations in utilizing exhaust waste heat, interfacing the system with engine control unit etc. We also explain the implementation of an optimum control strategy in the ACS control unit considering the influence of start-stop, initial start of the vehicle, electric drive mode in hybrid vehicles etc.

Indrasen Raghupatruni is with Robert Bosch Engineering and Business Solutions Private Limited, Bangalore, Karnataka 560095 India (phone: +49(711)811-3619048; e-mail: Indrasen.raghupatruni@in.bosch.com).

Dr. Michael Glora and Ralf Diekmann are with Robert Bosch GmbH, Schwieberdingen 71701 Germany (e-mail: Michael.glor@de.bosch.com, Ralf.diekmann@de.bosch.com).

Thomas Demmer is with Robert Bosch GmbH, Renningen 71272 Germany (e-mail: Thomas.Demmer@de.bosch.com).

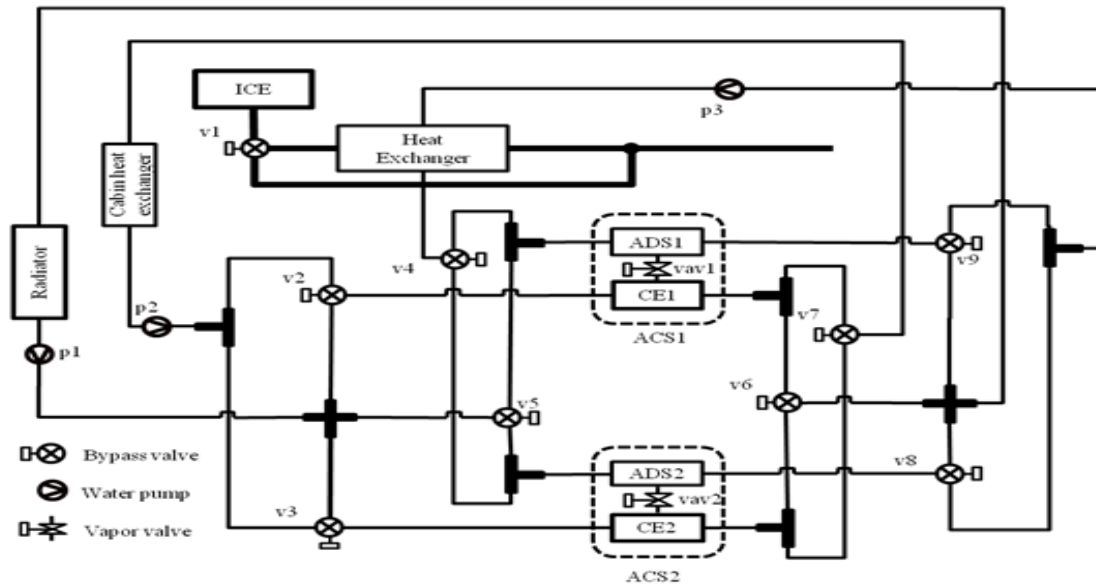

Fig. 1 Block diagram of adsorption air-conditioning system in prototype vehicle

II. SYSTEM DESCRIPTION

The block diagram of adsorption air-conditioning system prototype implemented in the vehicle is shown in Fig. 1. The vehicle used for this prototype is a passenger car having a turbocharged four cylinder gasoline engine with direct injection. Existing air-conditioning system in the vehicle has been modified by removing the compressor to accommodate the adsorption system, while retaining the cabin heat exchanger and blower. The exhaust path of the engine is connected to a high temperature heat exchanger through a bypass valve v1. Exhaust heat is used by the high temperature heat exchanger to heat the coolant for desorption of ADS blocks or is rejected to the atmosphere when desorption is not needed by both the blocks, with the help of this bypass valve.

The system comprises of two pairs of adsorption and unified condenser-evaporator units, CE1 and CE2. The basic working principle of two bed adsorption systems is described by [7] though in our implementation unified condensation & evaporation units are used instead of separate units.

Three thermal circuits i.e. the high temperature circuit, low temperature circuit and the cabin circuit contribute to the cooling effect in the cabin. High temperature circuit is used for circulating hot coolant through ADS1 or ADS2 blocks during desorption state and is the circuit involving heat exchanger, valves v4, v8, v9 as well as water pump p3. The low temperature is used for cooling the ACS units and comprises of the radiator with fan, pump p1, valves v5, v6, v8 and v9. The cabin circuit comprises of cabin heat exchanger with blower, pump p2, valves v2, v3 and v7. An ACS control unit is used to interface:

- 1) Temperature sensors placed at the inlets and outlets of ADS, CE, cabin, radiator, heat exchangers and also at the exhaust path of the ICE.
- 2) Pressure sensors placed inside ADS, CE units.
- 3) Water pumps and valves, which are actuated based on the

proposed control algorithm.

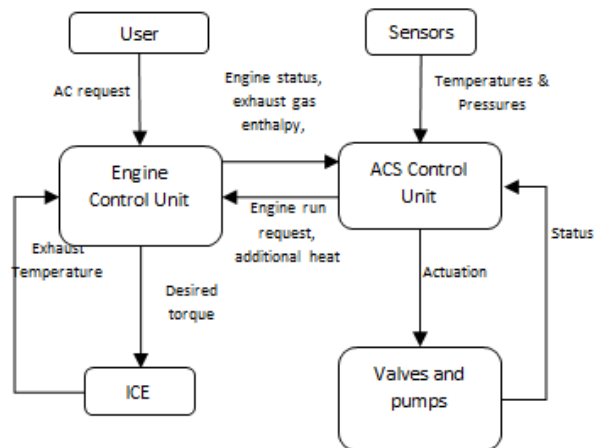

Fig. 2 Interface diagram of Engine control unit and ACS control unit

III. MATHEMATICAL MODELING

Lumped parameter model is used to model the system shown in Fig. 1. The non equilibrium adsorption rate as given by [11]

$$dw / dt = 15(D_{so} / R_p^2) \cdot \exp(-E_a / RT_{ADSi}) \cdot (W - w) \quad (1)$$

Modified Freundlich model (Refer to (1)) is used to describe the adsorption isotherms of RD type silica gel water pair.

$$W = A(T_{ADSi}) [P_s(T_{CEi}) / P_s(T_{ADSi})]^{B(T_{ADSi})} \quad (2)$$

where, $P_s(T_{CEi})$ and $P_s(T_{ADSi})$ are the corresponding saturation vapour pressures of the refrigerant at the CE units and ADS

units respectively. Also,

$$A(T_{ADSi}) = A_0 + A_1 T_{ADSi} + A_2 T_{ADSi}^2 + A_3 T_{ADSi}^3 \quad (3)$$

$$B(T_{ADSi}) = B_0 + B_1 T_{ADSi} + B_2 T_{ADSi}^2 + B_3 T_{ADSi}^3 \quad (4)$$

In (3) and (4), the values of A0...A3 and B0...B3 are given by [9]. The saturation vapor pressure and temperature are correlated as

$$P_s(T) = 0.000888 (T - 273.15)^3 - 0.0013802 (T - 273.15)^2 + 0.0857427 (T - 273.15) + 0.4709375 \quad (5)$$

Energy balance equations of adsorption and desorption units

$$(M \cdot c_{p,M} + M_{ref} \cdot c_{p,ref} + M_{metal} \cdot c_{p,metal}) dT / dt = M_{ads} (dw / dt) h - (\dot{m} c_p)_{ADSi} (T_{ADSi,out} - T_{ADSi,in}) \quad (6)$$

The output temperature of ADS unit is computed as

$$T_{ADSi,out} = T_{ADSi} + (T_{ADSi,in} - T_{ADSi}) \cdot \exp[-(UA)_{bed} / (\dot{m} c_p)_j] \quad (7)$$

Energy balance equations of evaporator and condenser

$$(M_{cp})_{CE} dT_{CE} / dt = \eta (h_{fg} M_{ADS} dw_{ADS} / dt) - (\dot{m} c_p) (T_{CEi,out} - T_{CEi,in}) \quad (8)$$

η is -ve for evaporation process and the output temperature of ADS unit is computed as

$$T_{CEi,out} = T_{evap} + (T_{CEi,in} - T_{evap}) \cdot \exp[-(UA)_{evap} / (\dot{m} c_p)_{CEi}] \quad (9)$$

IV. ALGORITHM AND SOFTWARE IMPLEMENTATION

A. Software Implementation and Interfaces with ECU

The interface diagram of the ACS control unit with Engine control unit (ECU) is shown in Fig. 2. Cooling request from the user with the temperature control knob is processed by the ECU and this request is sent to the ACS control unit along with the engine running status via the CAN interface. The ACS control unit processes this information along with the input from the sensors of the adsorption air-conditioning system mentioned in section II. Based on the exhaust heat temperature, ACS control unit requests the ECU additional heat from the engine exhaust if the temperature is not sufficient for the high temperature heat exchanger to desorb the ACS units. In case of a stop request to the engine due to the start-stop functionality in the ECU, ACS control unit sends request to the ECU for engine running if exhaust temperature is insufficient for desorption and to enable engine stop when the ADS units have been desorbed and ready for adsorption.

B. State Transition

State transition logic of the two adsorption machines is shown in Fig. 3. State transitions are chosen such that either

one of the ACS units is in adsorption state when there is a cooling request from the user. When the cooling request is switched off during engine running and if sufficient exhaust heat is available, the system is desorbed and prepared for adsorption in the next cycle. State transitions of each of the ACS units from adsorption to desorption is based on the condition that adsorption is complete, which is ascertained from the rate of decrease in the adsorption rate below a threshold limit. The methodology to compute adsorption rate is described in Section III.

State transition from desorption to preparation is based on the condition that desorption is complete, which is ascertained by increase in desorption rate below a threshold limit. State transition from preparation to adsorption is based on the condition that the ACS unit is sufficiently cooled. This is ascertained by verifying that the temperature difference between outlet and inlet of adsorber and condenser is below a threshold temperature. The state transition conditions T1 to T8 shown in Fig. 3 for transitioning between all the states is given in Table I.

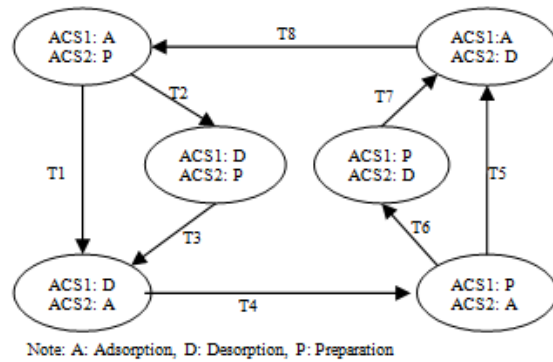

Fig. 3 State transition diagram

TABLE I
STATE TRANSITION CONDITIONS

Transition	Condition
T1	Cooling request active, ACS1 is adsorbed, preparation of ACS2 complete
T2	Cooling request inactive, ACS1 is adsorbed
T3	Cooling request active, preparation of ACS2 complete
T4	Cooling request active, ACS1 is desorbed
T5	Cooling request active, ACS2 is adsorbed, preparation of ACS1 is complete
T6	Cooling request inactive, ACS2 is adsorbed
T7	Cooling request active, preparation of ACS1 complete
T8	Cooling request active, ACS2 is desorbed

V. SIMULATION AND EXPERIMENTAL IMPLEMENTATION

A. Simulation Procedure

Heat and energy balance equations of the adsorber/desorber elements, evaporator/condenser elements described in Section III have been solved numerically with a model developed in Simulink in accordance to the adsorption air-conditioning system described in Section II. Ordinary differential equations in the proposed mathematical model have been solved simultaneously using the initial value problem technique.

Initial temperatures and flow rate conditions of the heat transfer fluids, adsorbent–refrigerant properties and the heat exchangers specifications are the input parameters of the simulation from which the cyclic operation of the adsorption air-conditioning system has been realized.

In order to simulate the two bed adsorption system with a unified evaporator and condenser unit, an approach similar to the implementation by [15] was used. Though in this case, a Stateflow[®] chart is used for the state transitions described in Table I. Stateflow[®] chart computes the states of ACS1 and ACS2 units based on the adsorption bed temperatures, inlet/outlet temperatures, internal temperatures and adsorption/desorption rates of the corresponding ACS/CE units. Based on the states of ACS1 and ACS2 actuation of the respective valves to operate different thermal circuits explained in the system description in Section II is simulated by switching the input temperature sources to the ADS element and CE element.

B. Experimental Procedure

Based on the simulation results, the control algorithm of adsorption air-conditioning system described in section II is validated in the prototype vehicle and the tests are carried out with temperature conditions similar to the simulation inputs i.e. during warm and dry weather conditions. Vehicle is driven in a pre-defined driving cycle which included the conditions necessary for a start-stop, continuous cooling demand for entire driving cycle, cold storage for a long duration and cooling request with the vehicle parked in sun for a long duration when the engine still switched off.

VI. RESULTS AND DISCUSSION

In order to validate the control algorithm implemented in prototype vehicle, simulation with the model and experiments in the prototype are executed under ambient temperature of approximately 295 K, with inlet temperature of 310K, heating source temperature of 400 K and coolant temperature of 300K.

Figs. 3 and 4 show the cyclic operation of ACS units based on the control logic in simulation and vehicle prototype respectively. Here values 1, 2 and 3 indicate preparation, adsorption and desorption of the ACS system respectively.

Simulation and validation results of the variations in vehicle cabin inlet temperature with respect to the ambient temperature, based on cyclic operation of the two ACS units is shown in Figs. 6 and 7 respectively. In case of simulation the ambient temperature is a constant value, but during vehicle validation the ambient temperature varied as a result of driving in the direction or opposite to the direction of wind, which had an impact on the air entering the cabin.

Figs. 8-11 show the simulation and validation results of cyclic operation of one of the ADS and CE units. Validation results of the ADS unit correspond to the simulation results, but in case of CE unit the results observed are not similar. This is due to the fact that there is an increase in the input temperature to the CE unit by the cabin heat exchanger caused by the airflow into the cabin when there is a cooling request from the user i.e. by increasing blower speed, which is not

considered in the simulation.

VII. CONCLUSION

Comparing the present prototype implementation i.e. Type-II system with existing Type-I implementations, several interesting advantages and disadvantages were observed.

A. Advantages

In the Type-I system, after condensation is completed, water has to be circulated to the evaporator for evaporation process to continue. So the condenser should be built to be at a higher position compared to the evaporator. In Type-II system since condenser and evaporator are the same element, both units can be at the same level which is of a particular advantage considering the space constrains in the vehicle. Also because of the same reason the size of Type-I systems are bulky and are better suited for stationary applications like building cooling.

B. Disadvantages

As seen in Fig. 1, Type-II systems require several valves compared to Type-I systems as the thermal circuits have to be switched frequently during adsorption, desorption and preparation process. Also it is observed in the prototype vehicle that the ADS and CE elements have to be cooled frequently with the cooling circuit which results in a loss of cooling power. It is also easier to shut off the cooling in Type-I systems compared to the Type-II system, this is attributed to the limitations of the vapor valves used between the ADS and CE units.

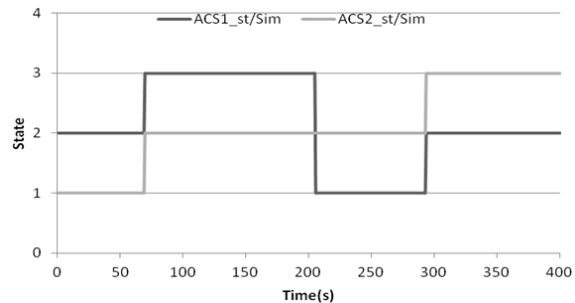

Fig. 4 ACS states in simulation

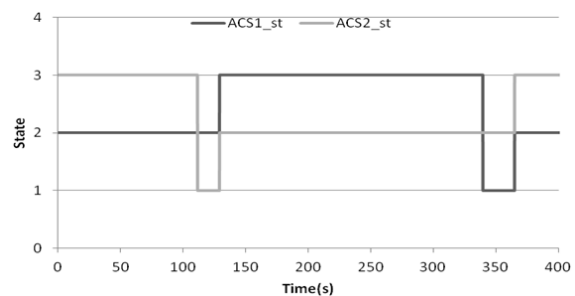

Fig. 5 ACS states in prototype vehicle

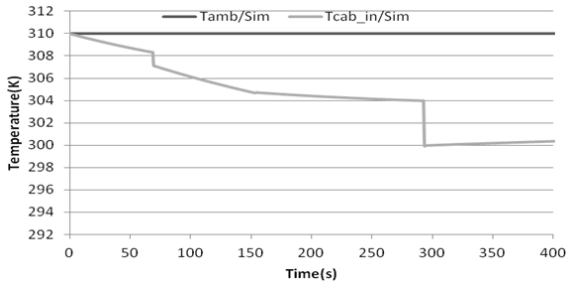

Fig. 6 Cabin inlet temperature with respect to ambient temperature in simulation

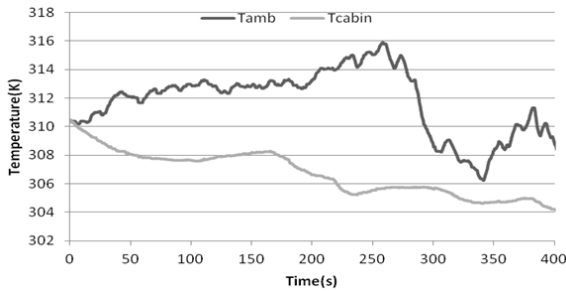

Fig. 7 Cabin inlet temperature with respect to ambient temperature in prototype vehicle

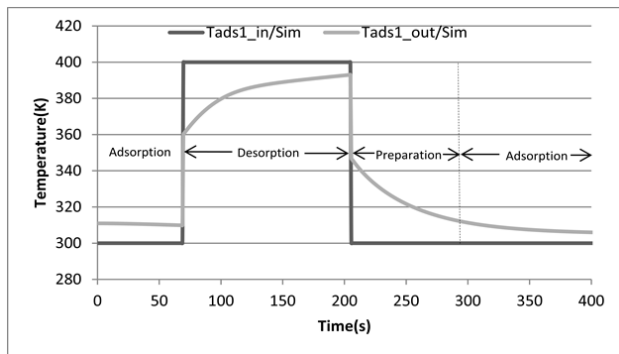

Fig. 8 ADS input and output temperatures in simulation

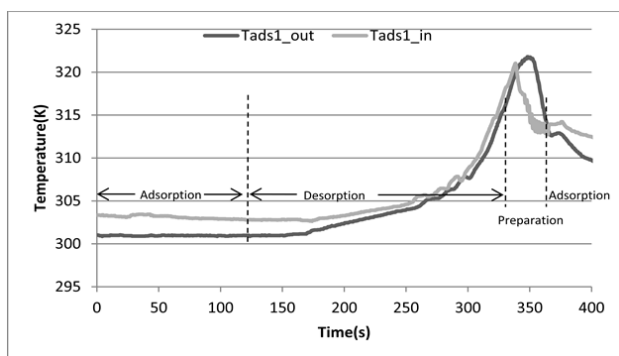

Fig. 9 ADS input and output temperatures in prototype vehicle

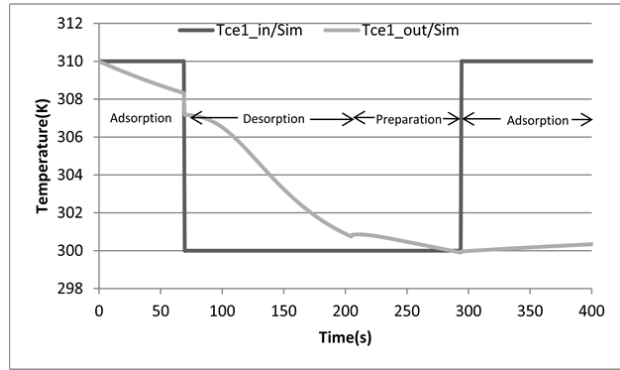

Fig. 10 CE input and output temperatures in simulation (without blower input)

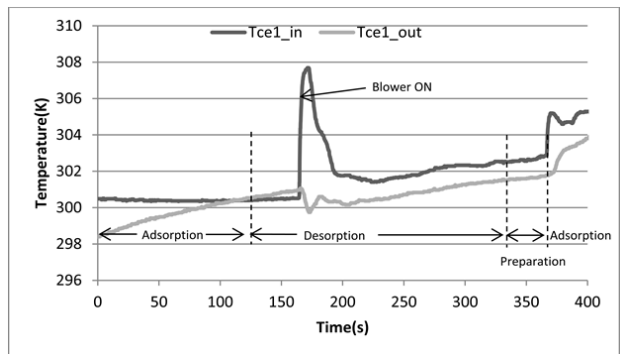

Fig. 11 CE input and output temperatures in prototype vehicle

In particular the adsorption air-conditioning system in the prototype is found to be advantageous during the start-stop phase when one of the ACS is prepared for adsorption before the engine start and also as a cold storage system during the first engine start, thereby reducing load on the engine compared to the conventional compressor based air-conditioning system. But the major disadvantage is the availability of sufficient exhaust heat when there is a continuous cooling demand during the entire driving cycle; this condition is satisfied by requesting additional heat from the engine, consequently resulting in higher fuel consumption.

NOMENCLATURE

- ICE Internal Combustion Engine
- ECU Engine Control Unit
- CAN Controller Area Network
- ADS Adsorption / Desorption unit
- CE Condensation / Evaporation unit
- ACS Adsorption system with ADS and CE units.
- i ACS unit number (1 or 2)
- j adsorption or desorption process
- W adsorption isotherm (kg kg^{-1})
- w adsorption capacity (kg kg^{-1})
- M mass (kg)
- c_p specific heat capacity ($\text{J kg}^{-1} \text{K}^{-1}$)
- h enthalpy (J kg^{-1})
- P system pressure (kPa)
- T temperature (K)
- t time (s)

$\frac{dw}{dt}$	rate of change of adsorption (s^{-1})
D_{so}	pre exponential constant ($m^2 s^{-1}$)
E_a	activation energy ($J kg^{-1}$)
R	gas constant ($J kg^{-1} K^{-1}$)
\dot{m}	mass flow rate ($kg s^{-1}$)
R_p	adsorbent particle radius (m)
A	area (m^2)
U	overall heat transfer coefficient ($W m^{-2} K^{-1}$)

REFERENCES

- [1] Farrington R and Rugh J "Impact of Vehicle Air-Conditioning on Fuel Economy, Tailpipe Emissions, and Electric Vehicle Range". *National Renewable Energy Laboratory* (2000).
- [2] Rhea Valentina, Alexander Vieh, Oliver Bringmann, Wolfgang Rosenstiel "HVAC System Modeling for Range Prediction of Electric Vehicles" *Intelligent Vehicles Symposium Proceedings, 2014 IEEE, 1145 - 1150*.
- [3] Waleed A. Abd-Fadeel & Soubhi Ali Hassanien "Temperature variations in a parked car exposed to direct sun during hot and dry climates" *International Journal of Automobile Engineering Research & Development (IJAUERD) ISSN 2277-4785 Vol. 3, Issue 1, Mar 2013, 75-80*.
- [4] de Boer R "Thermally operated Mobile Air Conditioning Systems" Presented at 3rd European Workshop – *Mobile Air Conditioning, Vehicle Thermal Systems and Auxiliaries* (2009).
- [5] Zhong Yongfang, Wert Kevin L, and Fang Tiegang, "An Adsorption Air-Conditioning System to Reduce Engine Emissions and Fuel Consumption for Heavy-Duty Vehicles" (2010) *International Refrigeration and Air Conditioning Conference*. Paper 1100.
- [6] Salvador M. Aceves "Adsorption Air Conditioner for Electric Vehicle Applications" *American Institute of Chemical Engineers San Francisco, CA (1994)*.
- [7] Zhang L.Z. "Design and testing of an automobile waste heat adsorption cooling system" (2000) *Applied Thermal Engineering*, 20:p.103-114.
- [8] Vicatos G, Gryzagoridis J, Wang S "A car air-conditioning system based on an absorption refrigeration cycle using energy from exhaust gas of an internal combustion engine" *Journal of Energy in Southern Africa Vol 19 No 4 November 2008*.
- [9] Miyazakia T, Akisawaa A, Saha B. B, El-Sharkawy I.I, Chakraborty A "A new cycle time allocation for enhancing the performance of two-bed adsorption chillers" *International journal of refrigeration* 32(2009) 846 – 853.
- [10] Deshpande A C, Pillai R M "Adsorption Air-Conditioning (AdAC) for Automobiles Using Waste Heat Recovered from Exhaust Gases" *Second International Conference on Emerging Trends in Engineering and Technology, ICETET-09*.
- [11] Zhuaa H.T, Nga K.C, Maleka A, Kashiwagib T, Akisawab A, Saha B. B "Modeling the performance of two-bed, silica gel-water adsorption chillers" *International Journal of Refrigeration* 22 (1999) 194–204.
- [12] El-Sharkawya I.I, AbdelMeguida H, Saha B.B "Towards an optimal performance of adsorption chillers: Reallocation of adsorption/desorption cycle times" *International Journal of Heat and Mass Transfer Volume 63, August 2013, Pages 171–182*.
- [13] Wang D.C, Xia Z.Z, Wu J. Y, Wang R.Z, Zhai H, Dou W.D "Study of a novel silica gel-water adsorption chiller. Part I. Design and performance prediction" *International Journal of Refrigeration* 28 (2005) 1073-1083.
- [14] Ang Li, Azhar Bin Ismil, Kyaw Thu, Kim Choon Ng, Wai Soog Loh "Performance evaluation of zeolite-water adsorption chiller with entropy analysis of thermodynamic insight" *Applied Energy* 130 (2014) 702-711.
- [15] Zhang G, Wang D. C, Zhang J. P, Han Y. P, Wanchao Sun "Simulation of operating characteristics of the silica gel-water adsorption chiller powered by solar energy" *Solar Energy* 85 (2011) 1469 – 1478.