

# Adaptive Radio Resource Allocation for Multiple Traffic OFDMA Broadband Wireless Access System

Lu Yanhui, Zhang Lizhi, Yin Changchuan, and Yue Guangxin

**Abstract**—In this paper, an adaptive radio resource allocation (RRA) algorithm applying to multiple traffic OFDMA system is proposed, which distributes sub-carrier and loading bits among users according to their different QoS requirements and traffic class. By classifying and prioritizing the users based on their traffic characteristic and ensuring resource for higher priority users, the scheme decreases tremendously the outage probability of the users requiring a real time transmission without impact on the spectrum efficiency of system, as well as the outage probability of data users is not increased compared with the RRA methods published.

**Keywords**—OFDMA, adaptive radio resource allocation, QoS.

## I. INTRODUCTION

NEXT generation wireless communication systems (beyond 3G) will be required to provide flexible and easy deployment solution to high-speed communications and support a variety of services utilizing advanced multiple access techniques. This means that the network will have to accommodate users with different traffic classes and quality of service (QoS) requirements.

Orthogonal Frequency Division Multiple Access (OFDMA) has attracted interest as one of the best candidates to achieve that goal [1-3]. OFDMA is based on OFDM, so it not only inherits OFDM's immunity to inter-symbol interference and frequency selective fading [4], but also increases multi-user diversity by acting the channel fading as a channel randomizer. And its performance depends on the ability to provide efficient and flexible resource allocation, which is limited by the scarce radio spectrum. A good radio resource allocation scheme should adapt to wireless fading channel, as well as improve the spectrum efficiency and satisfy active users with different traffic class.

Manuscript received December 9, 2005. This work was supported by the Innovation Fund for Outstanding Scholar of He'nan Province (No. 04210000100), the National Science Foundation of China (No.60472070) and the Key Project of Chinese Ministry of Education (No.105035)

Lu Yanhui, Yin Changchuan and Yue Guangxin are with Beijing University of Post and Telecommunications, Beijing 100876, China (phone: 86-10-62282146-812, e-mail: luyh710@sohu.com, ccyin@bupt.edu.cn, gxyue@bupt.edu.cn).

Zhang Lizhi is with National Digital Switching System Engineering & Technological R&D Center, Zhengzhou, He'nan Province, 450002, China

In OFDMA system, the radio resource allocation problem can be formulated as joint optimization problem in the physical layer and medium access control (MAC). That is, sub-carrier, bit and power are allocated adaptively. Currently, two optimization problems exist in the literature. They are margin adaptive (MA) and rate adaptive (RA) respectively. The margin adaptive optimization's objective is to achieve the minimum overall transmit power with the constraints on the user data rates. The rate adaptive optimization's goal is to maximize the minimum user's capacity on the total transmit power constraint. These optimization problems are non-linear and computationally complex. In order to obtain optimal or sub-optimal results, several dynamic allocation schemes are proposed in [5-10, 14-15].

In [5] and [10], a Lagrange-based algorithm to achieve a dramatic gain is proposed independently. However, the prohibitively high computational complexity renders them impractical. To reduce the complexity in [5], a heuristic sub-carrier allocation algorithm is proposed in [7] and [8]. The two schemes both assume fixed modulation modes. Otherwise, the QoS requirement is defined as achieving a specified data transmission in [7], data rate and bit error rate (BER) in [8]. The schemes addressed in [9] and [6] are low complexity and sufficiently deal with the fair of every data user in system.

However, none of the aforementioned adaptive algorithms have taken into account the impact of radio resource allocation scheme on voice user. It is no doubt that voice service and data service coexist in both current systems and future mobile communication system. Voice and data users have quite different traffic characteristics and QoS requirements. Voice traffic requires a real time transmission but can tolerate a moderate bit error rate. Notwithstanding, data traffic can accept the varied transmission delay but it requires a lower BER.

In this paper, we propose a radio resource allocation scheme supporting multi-traffic class, whose objective is to reduce outage probability of voice user and improve the system performance.

This paper is organized as follows: section II talks about multi-user OFDM system model and investigates the resource allocation problems in OFDMA system. In section III, we briefly review the sub-optimal allocation scheme developed in [6], and present a resource allocation scheme supporting

multi-traffic class. In section IV, various simulation results are discussed, and the system performance is evaluated. Finally, we conclude this paper in section V.

## II. SYSTEM MODEL

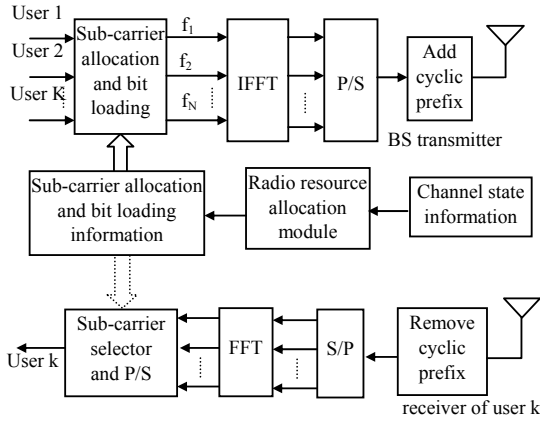

Fig. 1 Downlink System Structure of OFDMA

The structure of a multi-user OFDM system is shown in Fig. 1. The considered downlink OFDMA system consists of a single cell with one Base Station (BS), communicating simultaneously with  $K$  user using  $N$  OFDM sub-carrier. In order to overcome frequency selective fading causing inter-symbol interference, the bandwidth of each sub-carrier is chosen to be sufficiently smaller than the coherence bandwidth of the channel. Then, each OFDM sub-carrier  $n$ , as perceived by user  $k$ , is subject to flat Rayleigh fading, path loss and shadowing with channel gains  $\alpha_{k,n}$ . In addition, the signals suffer from AWGN noise, whose single-sided noise power spectral density level  $N_0$  is considered equal to unity (i.e.  $N_0=1$ ), for all sub-carriers and is the same for all users. We assume that the BS has a perfect knowledge of the Channel State Information (CSI) i.e.  $\alpha_{k,n}$ , and the channel is slowly variable so that the proposed allocation algorithm convergence within the channel coherence time. Using known CSI, radio resource allocation module in BS applies the sub-carrier allocation and bit-loading algorithm to assign different sub-carrier to different user and the number of bits/OFDM symbol to be transmitted on every sub-carrier. Corresponding quadrature amplitude modulation (QAM) scheme is used in each sub-carrier depending on the number of bits assigned to it.

After the sub-carrier allocation and bit loading of users' data, Inverse Fast Fourier Transform (IFFT) transforms the complex symbols into the time domain samples. Cyclic extension of the time domain samples, known as the guard interval, is then added to ensure orthogonal between the sub-carriers. Provided that the maximum time dispersion is less than the guard interval, the signals are then transmitted via downlink channels.

We assume that the sub-carrier and bit allocation information is sent to the receivers via a separate control channel. At the

receiver, removing the cyclic prefix and performing FFT, then the data of user  $k$  are extracted according to the sub-carrier and bit allocation information.

Let  $c_{k,n}$  denote the number of bits of the  $k$ th user that are assigned on the  $n$ th sub-carrier, so  $c_{k,n}$  must be integer in the set  $D=\{0,1,2,\dots,M\}$ . As no more than one user is allowed in a sub-carrier in OFDMA system, it follows that for each  $n$ , if  $c_{k',n} \neq 0$ ,  $c_{k,n} = 0$  for all  $k \neq k'$ . We define  $\rho_{k,n}$  as the indicator of allocating the  $n$ th sub-carrier to the  $k$ th user. That is,  $\rho_{k,n} = 1$  when the  $n$ th sub-carrier is assigned to the  $k$ th user, while  $\rho_{k,n} = 0$ , otherwise. The required QoS of the  $k$ th user is described by its minimum data rate requirement equal to  $r_k$  bits per OFDM symbol and target bit error rate  $BER_k$ .

The transmission power allocated to the  $n$ th sub-carrier of the  $k$ th user is expressed as

$$P_{k,n} = \frac{g_k(c_{k,n}, BER_k)}{\alpha_{k,n}^2} \quad (1)$$

Where  $g_k(c_{k,n}, BER_k)$  is the required received power with unity channel gain for reliable reception of  $c_{k,n}$  bits per symbol, and it depends on the target BER of the  $k$ th user.

The goal of the margin adaptive (MA) sub-carrier, bit and power allocation algorithm is to find the best assignment of  $c_{k,n}$  so that the overall transmit power, the sum of  $P_{k,n}$  over all sub-carriers and all user, is minimized for given transmission rates of the users and given QoS requirements. In order to make the problem tractable, we further require  $g_k(\cdot)$  is a convex and increasing function with  $g_k(0, BER_k) = 0$ . This condition essentially means that no power is needed when no bit is transmitted and that the required additional power to transmit an additional bit increases. Almost all popular coding and modulation scheme satisfy this condition.

Mathematically, we can formulate the MA problem as:

$$\min_{c_{k,n}} \sum_{n=1}^N \sum_{k=1}^K \frac{g_k(c_{k,n}, BER_k)}{\alpha_{k,n}^2} \quad (2)$$

Subject to

$$r_k = \sum_{n=1}^N c_{k,n} \quad \forall k \in \{1,2,\dots,K\} \quad (3)$$

$$c_{k',n} \neq 0, c_{k,n} = 0 \quad \forall k \neq k', \forall n \in \{1,2,\dots,N\} \quad (4)$$

RA problem whose objective is maximize the total system throughput on the total transmit power constraint is slightly different from MA. It can be formulated as:

$$\max_{c_{k,n}, \rho_{k,n}} \sum_{k=1}^K \sum_{n=1}^N \rho_{k,n} c_{k,n} \quad (5)$$

Subject to

$$\sum_{k=1}^K \sum_{n=1}^N P_{k,n} \leq P_{\max} \quad (6)$$

$$\rho_{k',n} = 1, \rho_{k,n} = 0 \quad \forall k \neq k', \forall n \in \{1,2,\dots,N\} \quad (7)$$

Where  $P_{max}$  is the total power constraint.  $c_{k,n}$  is the function of the target  $BER_k$ , the transmit power  $P_{k,n}$  and channel gains  $\alpha_{k,n}$ . That is

$$c_{k,n} = f(BER_k, P_{k,n}, \alpha_{k,n}) \quad (8)$$

Both MA problem and RA problem are nonlinear and very hard to solve. Although the optimal solution exists, from an implementation point of view, it is not preferred since in a time varying channel, the allocation algorithm should be fast enough to allocate the sub-carriers within the coherence time. Several practical sub-optimal schemes that are close to the optimal solution are developed. One of them is the method proposed by Y.J. Zhang et.al in [6]. It is low complexity and the QoS requirements of users are fulfilled.

### III. SUBCARRIER ALLOCATION AND BIT LOADING FOR MULTIPLE TRAFFIC

Before presenting the sub-carrier and bit allocation scheme for multi-traffic class, we briefly restate the algorithm addressed by Y.J. Zhang et.al, which is the basis of it.

In [6], considering the minimum transmission rates requirement of users, a reduced-complexity joint sub-carrier and bit allocation algorithm is developed based on distributing the total transmit power to each sub-carrier equally. So the problem is mathematically formulated as follows:

$$\max_{c_{k,n}, \rho_{k,n}} \sum_{k=1}^K \sum_{n=1}^N \rho_{k,n} c_{k,n} \quad (9)$$

Subject to

$$\sum_{n=1}^N \rho_{k,n} c_{k,n} \geq r_k \quad \forall k \in \{1, 2, \dots, K\} \quad (10)$$

$$\rho_{k',n} = 1, \rho_{k,n} = 0 \quad \forall k \neq k', \forall n \in \{1, 2, \dots, N\} \quad (11)$$

Since the transmit power  $P_{k,n}$  is fixed and known,  $c_{k,n}$  can be pre-calculated based on formula (8) given that the channel gain  $\alpha_{k,n}$  is available at the BS. By doing so, the problem in formula (9)~(11) is converted into a linear optimization problem with  $\rho_{k,n}$  as the only variables. In order to reduce the computational complexity, the problem is decomposed into two procedures. First, the sub-carriers are allocated to maximize the throughput defined by formula (9) without considering the rate constraints in formula (10). That is, the maximum throughput is achieved by allocating a sub-carrier to the user who can transmit the largest number of bits on it. This yields an optimum solution corresponding to the unconstrained problem (In the following of the paper, we denoted the method providing optimum solution as MAX THROUGHPUT.). Afterwards, the sub-carrier allocation is adjusted step by step to satisfy the rate constraints in (10) one by one, until all constrains are satisfied. Consequently, the sub-carrier reallocation will inevitably cause a decrease in the overall throughput.

Although the scheme in [6] exhibits tremendous gain compared to the adaptive systems with fixed multiple-access, it is not the best favor when multi-traffic class users exist in system, especially voice user requiring a real time transmission.

As we see, the method presented in [6] always rejects the user without the best channel conditions in every sub-carrier in each steps, despite that it is enough to transmit a bit or more bits. Consequently, the probability with insufficient data rate increases.

To solve this problem, we propose an adaptive sub-carrier and bit allocation scheme for OFDMA system with multi-traffic class (MTC), where the users are classified and prioritized according to their traffic characteristic. To simply the analysis, only two class users are considered in the paper. The users requiring a real time transmission are denoted as class one, and they are firstly assigned sub-carrier and bits one by one. Then, the algorithm given by Y.J. Zhang et.al in [6] is applied to other users denoted as class two. In every step of MTC, the objective of maximizing the total throughput is guaranteed.

In the following, the algorithm is described in detail.

- 1) Work out the  $c_{k,n}$  according to the current channel information and target BER requirements in given OFDM symbol assuming the assigned power to each sub-carrier is equal.  $c_{k,n}$  can be calculated by formula (8).
- 2) Allocate the sub-carriers and bits for class-one users one by one. That is selecting the sub-carrier  $n^*$  in the set  $\{1, \dots, N\}$  to transmit data for each class-one user sub-carrier by sub-carrier, until its target rate is achieved. In OFDMA system, a sub-carriers is permitted to transmit data of one user, so  $\rho_{k,n} = 1$  if the  $n^{\text{th}}$  sub-carrier is assigned to the  $k^{\text{th}}$  user; otherwise  $\rho_{k,n} = 0$ . Note that all  $\rho_{k,n}$  have been initialized to zero.

$$n^* = \arg \max_{n \in \{1, \dots, N\}} c_{k,n} \quad (12)$$

- 3) Allocate residual sub-carriers with  $\rho_{k,n}$  equal to zero according to formula (13) by selecting the user  $k^*$  to transmit data in each sub-carrier.

$$k^* = \arg \max_{k \in \{1, \dots, K\}} c_{k,n} \quad (13)$$

When the  $n^{\text{th}}$  sub-carrier is assigned to the  $k^{\text{th}}$  user,  $\rho_{k,n} = 1$ , otherwise  $\rho_{k,n} = 0$ . Note that  $k^*$  belongs to  $\{1, \dots, k\}$ , including voice users and data users.

- 4) Reallocate the sub-carrier to guarantee the data users' minimum rate requirements. Sub-carrier reallocation is carried out on a user-by-user basis for all users whose minimum rate constrains have not been satisfied yet, which are denoted as  $k'$ . Furthermore, we denoted the sub-carriers

assigned to the users whose  $\sum_{n=1}^N \rho_{k,n} c_{k,n} \geq r_k$  as  $n'$ . For each  $k'$ , the reallocation can be realized by minimizing the cost function:

$$e_{k',n'} = \frac{c_{k,n'} - c_{k',n'}}{c_{k,n'}} \quad (14)$$

That is selecting sub-carrier  $n^{*}$  to transmit the data of user  $k'$ .

$$n^{*} = \arg \min_{n'} e_{k',n'} \quad (15)$$

To achieve an optimum feasible solution in the end, a sub-carrier  $n'$  that has been assigned to user  $k$  can not be reallocated to other users if the reallocation will cause the violation of user  $k$ 's data rate requirement.

#### IV. PERFORMANCE COMPARISON

In this section, the performance of the MTC scheme is obtained and compared with other sub-carrier and bit allocation method, mainly the one proposed by Y.J. Zhang in [6].

We consider a system that employs M-ary quadrature amplitude modulation. The required transmission power for  $c$  bits/sub-carrier at a given BER with unity channel gain is<sup>[12]</sup>

$$\frac{N_0}{3} \left[ Q^{-1} \left( \frac{BER}{4} \right) \right]^2 (2^c - 1) \quad (16)$$

Where  $Q^{-1}(x)$  is the inverse function of

$$Q(x) = \frac{1}{\sqrt{2\pi}} \int_x^{\infty} e^{-\frac{t^2}{2}} dt \quad (17)$$

To evaluate the performance of our scheme, we have conducted simulations using system and channel model described in section II, and the path loss is considered as a zero-mean Gaussian variable in the logarithmic scale responsible for shadowing with a standard deviation. We consider a circular cell with eight users, independently and uniformly distributed within the cell. The simulation parameters are shown in Table I.

TABLE I  
SIMULATION PARAMETES

Parameter	Value
Number of subcarrier	128
Number of users	8
Target BER of voice user	1.0e-2
Target BER of data user	1.0e-4
Target rate of voice user	8bits/OFDM symbol
Data user's minimum rate requirement	64bits/OFDM symbol
Path Loss Exponent	4
Standard Deviation of Lognormal Shadowing	8dB

For comparison purposes, the fixed sub-carrier and bit allocation method is also considered, which is denoted as FIXED in the following. The method work as follows: each user is assigned a predetermined band of sub-carrier and transmits data according to the number of bits pre-calculated using formula (8). In this paper, the numbers of sub-carriers assigning to every user is 16, despite it is voice user and data user.

Fig. 2~Fig. 7 show the performance of the proposed adaptive sub-carrier and bit allocation algorithm for multi-traffic class

(MTC) compared with other adaptive radio resource allocation scheme.

The system performance is evaluated by spectrum efficiency and outage probability. The spectrum efficiency is denoted as the average number of bits transmitted by a sub-carrier, and the outage probability indicates the number of the OFDM symbols terminated due to insufficient data rate versus the total numbers of OFDM symbols simulated by the method.

Fig. 2 shows the spectrum efficiency versus transmit SNR/OFDM symbol of an eight-user OFDM system, where there is a voice user, for different sub-carrier and bit allocation schemes.

Fig. 3 is the spectrum efficiency of every sub-carrier and bit allocation schemes when the number of voice users is changed from one to eight, and the transmit SNR/OFDM symbol is equal to 12dB.

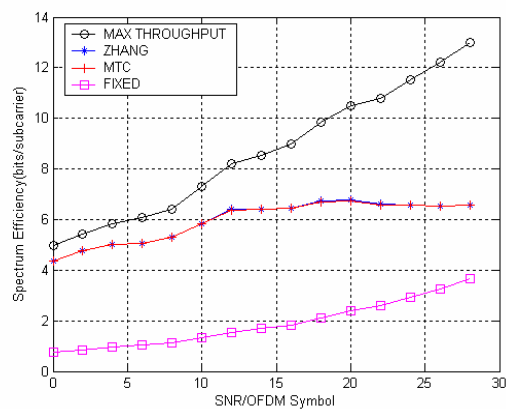

Fig. 2 Spectrum efficiency versus average received SNR/OFDM symbol for sub-carrier and bit allocation

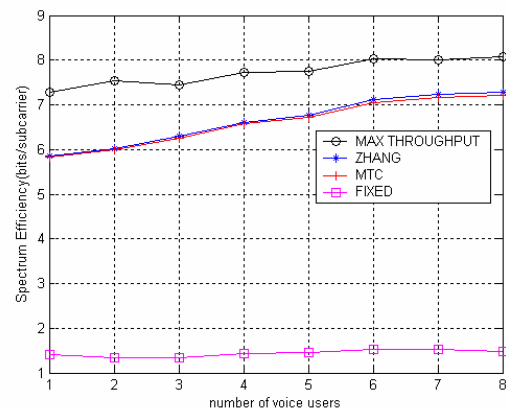

Fig. 3 Spectrum efficiency versus the number of voice users when SNR/OFDM symbol =12dB

From Fig. 2 and Fig. 3, we find that the spectrum efficiency of the method proposed for MTC is much closed the method addressed by Y.J.Zhang, which is denoted as ZHANG in the figures, and it is obvious that they are superior to FIXTED and inferior to MAX THROUGHPUT. From Fig. 3, we observe that the spectrum efficiency of each allocation algorithm increases slightly with the number of voice users. That is

because the target BER of voice user  $1.0 \times 10^{-2}$  is quite larger than that of data user  $1.0 \times 10^{-4}$ . It is well known that the  $c_{k,n}$  increases as the BER with same received SNR[12] or same transmitted power and channel condition, therefore leading to higher spectrum efficiency.

Fig. 4 shows the outage probability of voice user versus transmit SNR/OFDM symbol of an eight-user OFDM system, where there is a voice user, for different sub-carrier and bit allocation schemes. Fig. 5 is the outage probability of voice users when the number of voice users is changed from one to eight, and the transmit SNR/OFDM symbol is equal to 12dB. In Fig. 4 and Fig. 5, we observed that the outage probability of the method proposed for MTC is smallest in the four schemes. Moreover, we find it not only outperforms fixed and max throughput methods, but also decrease about 10% with ZHANG in despite of the number of the voice users when the transmit SNR/OFDM symbol is equal to 12dB.

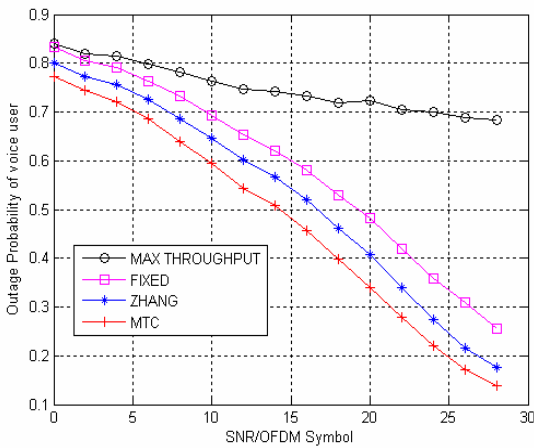

Fig. 4 Outage probability of voice user versus average received SNR/OFDM symbol

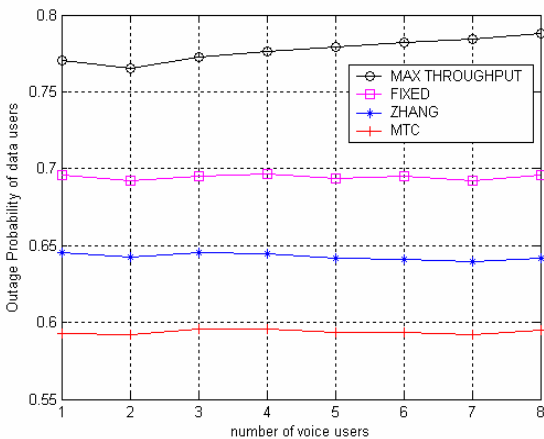

Fig. 5 Outage probability of voice users versus the number of voice users when SNR/OFDM symbol = 12dB

Fig. 6 and Fig. 7 give out the outage probability of data users obtained by different sub-carrier and bit allocation versus SNR and the number of voice users, respectively. They demonstrate

that the outage probability of data users is not impacted by MTC scheme when the outage probability of voice users is improved, compared with other there methods. In Fig. 7, when the number of voice users is equal to 8, the number of data users is zero, so the outage probably of data users is set to zero.

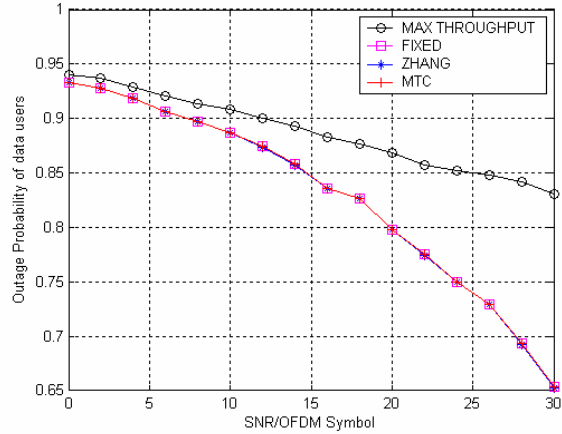

Fig. 6 Outage probability of data user versus average received SNR/OFDM symbol

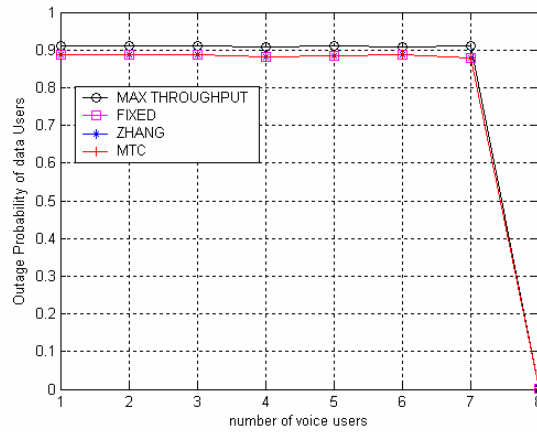

Fig. 7 Outage probability of data users versus the number of voice users when SNR/OFDM symbol = 12dB

V. CONCLUSION

In this paper, we have proposed a utility algorithm, which allows for an efficient allocation of radio resource (sub-carrier and bit) supporting for the users with different traffic class in the OFDMA system. The performance of the proposed algorithm, expressed as spectrum efficiency and outage probability, is significantly better than the performance of the method addressed by Y.J.Zhang in [6].

REFERENCES

- [1] Hermann Rohling and Rainer Grunheid, "Performance Comparison of Different Multiple Access Schemes for the Downlink of an OFDM Communication System", 1997
- [2] Guoqing Li and Hui Liu, "On the Optimality of the OFDMA Network", July 15, 2004, Draft
- [3] Wu Junli, Teng Yong, Yin Changchuan and Yue Guangxin, "On Performance of Multiple Access for OFDM Transmission Technique in

- Rayleigh Fading Channel”, Proceedings of ICCT2003
- [4] R.Berezdivin, R.Breinig, and R.Topp, “Next-generation Wireless Communications Concepts and Technologies,” *IEEE Commun. Mag.*, Vol.40, pp.108-116, Mar.2002
  - [5] C.Y.Wong, R.S.Cheng, K.B.Letaief and R.D.Murch, “Multicarrier OFDM with Adaptive Subcarrier, Bit, and Power Allocation”, *IEEE J.Select. Areas Commun.*, Vol. 17, No. 10, pp.1747-1758 Oct. 1999.
  - [6] Ying Jun Zhang, K.B.Letaief, “Multiuser Adaptive Subcarrier-and-Bit Allocation With Adaptive Cell Selection for OFDM Systems”, *IEEE Transactions on Wireless Communications*, Vol.3, No.5, Sept.2004
  - [7] C.Y.Wong, C.Y.Tsui, R.S.Cheng, and K.B.Letaief, “A Real-time Subcarrier Allocation Scheme for Multiple Access Downlink OFDM Transmission,” in *IEEE Proc. VTC’99*, vol.2, 1999, pp.1124-1128
  - [8] Slawomir Pietrzyk, Gerard J.M.Janssen, “Multiuser subcarrier Allocation for QoS Provision in the OFDMA Systems”, in *Proc. VTC 2002*, Vol.2, 2002, pp.1077-1081 Fall.
  - [9] M.Ergen, S.Coleri, and P.Varaiya, “QoS Aware Adaptive Resource Allocation Techniques for Fair Scheduling in OFDMA Based Broadband Wireless Access Systems”
  - [10] Zukang Shen, “Multiuser OFDM Capacity Analysis with Partial Channel Information”, Multiuser Wireless Communications Course Project, Fall 2002
  - [11] D.G. Luenberger, *Optimization by Vector Space Methods*, New York: Wiley, 1969.
  - [12] J.G. Proakis, *Digital Communication*, 3<sup>rd</sup> ed. New York: McGraw-Hill, 1995.
  - [13] T.S. Rappaport, *Wireless Communications Principles and Practice*, Englewood Cliffs, NJ: Prentice-Hall, 1996.
  - [14] Kong Jian, Liu Fang, Wang Wen-bo, Liu Yuan-an, “Loading Schemes for Downlink OFDMA System,” *The Journal of China Universities of Posts and Telecommunications*, Vol.11, No.4, pp.86-90, Dec.2004.
  - [15] Zhou Wenan, Li Zhen, Zhuge Qing, Song Junde, “An Optimal Bit Loading Algorithm in Multi-cell Multi-user OFDM Systems,” *The Journal of China Universities of Posts and Telecommunications*, Vol.27 Sup., pp.212-216, Dec.2004.