

# A WIP control based on an intelligent controller

Chih-Hui Chiu and Chun-Hsien Lin

**Abstract**—In this study, a robust intelligent backstepping tracking control (RIBTC) system combined with adaptive output recurrent cerebellar model articulation control (AORCMAC) and  $H^\infty$  control technique is proposed for wheeled inverted pendulums (WIPs) real-time control with exact system dynamics unknown. Moreover, a robust  $H^\infty$  controller is designed to attenuate the effect of the residual approximation errors and external disturbances with desired attenuation level. The experimental results indicate that the WIPs can stand upright stably when using the proposed RIBTC.

**Keywords**— wheeled inverted pendulum; backstepping tracking control;  $H^\infty$  control; adaptive output recurrent cerebellar model articulation control.

## I. INTRODUCTION

IN the past several years, there are many literatures to study inverted pendulum [1]–[3]. The main topic of this research is to keep the pendulum balance at the upright position. Until now, the rail-cart structure is the most usual type in control experiments. Nowadays, many studies of extensions of the rail-cart inverted pendulum control system have been proposed. The most interesting and challenging problem is how to control a mobile wheeled inverted pendulum system which the cart is no longer run on a guide rail. In [4], A novel AORCMAC was utilized to control wheeled inverted pendulums (WIPs) that have a pendulum mounted on two coaxial wheels.. Graser et al. [5] used Newtonian approach and linearization method to get a dynamic model to design a controller for a mobile inverted pendulum. Ren et al. [6] proposed a self-tuning PID control strategy, based on a deduced model, for implementing a motion control system that stabilizes a two-wheeled vehicle (TWV) and follows the desired motion commands. In [7], the authors presented an interesting pedagogical tool, a self-balancing human transportation vehicle (HTV).

Cerebellar model articulation controller (CMAC) is a type of associative memory neural network inspired by neurophysiologic theory of the cerebellum. The major advantages of CMAC included simple computation, fast learning property, good generalization capability, and easier hardware implementation. The application of CMAC can be found in many fields such as signal processing, pattern recognition, and control system. However, the major drawback of existing CMAC is that they belong to static networks. In other words, the application domain of CMAC will be limited to static mapping due to its feedforward network structure [8].

The recently developed backstepping control technique is a powerful and systematic design methodology.

The key idea of backstepping design is to select recursively some appropriate functions of state variables as fictitious control inputs for lower dimension subsystems of the overall system. The procedure terminates a feedback design for the true control input which achieves the original design objective by virtue of a final Lyapunov function. Thus the backstepping control approach is capable of keeping the robustness properties with respect to the uncertainties [9][10].

Since the dynamic characteristics of WIPs are nonlinear and the precise models are difficult to obtain, the traditional control approaches are hard to be implemented. To overcome this drawback, a robust intelligent backstepping tracking control (RIBTC) system has been proposed for WIPs implementation. The developed RIBTC system is comprised of an adaptive output recurrent cerebellar model articulation controller (AORCMAC) and a robust  $H^\infty$  controller. The AORCMAC is used to mimic an ideal backstepping control (IBC), and a robust  $H^\infty$  controller is designed to attenuate the effect of the residual approximation errors and external desired attenuation level. In this study, the output recurrent cerebellar model articulation controller (ORCMAC) architecture is a modified version of the conventional CMAC network. Since the proposed controller captures the dynamic response of controlled system, the ORCMAC will achieve good control performance for a nonlinear system. The all adaptation laws of the RIBTC system are derived based on the Lyapunov stability analysis, the Taylor linearization technique and  $H^\infty$  control theory, so that the stability of the closed-loop system and  $H^\infty$  tracking performance can be guaranteed. Finally, the effectiveness of the proposed WIP system control is verified by real-time experimental results.

## II. DEVELOPMENT OF ROBUST INTELLIGENT BACKSTEPPING TRACKING CONTROL SYSTEM FOR WIP

Nowadays, many studies of extensions of the one-dimensional inverted pendulum control system have been proposed. Fig. 1 shows the WIP system with its three degrees of freedom. Consider the wheeled inverted pendulum, where the dynamic equation is described as following [5]:

$$\begin{aligned}\dot{x}_1(t) &= x_2(t) \\ \dot{x}_2(t) &= f(x,t) + g(x,t)u(t) + d(t)\end{aligned}\quad (1)$$

where  $x = [x_1(t), x_2(t)]^T = [x(t), \dot{x}(t)]^T$  is the state vector of the wheeled inverted pendulum system which is assumed to be available for measurement,  $f(x,t) \in R$  is the nonlinear dynamic function,  $g(x,t) \in R$  denotes the

Department of Electrical Engineering, Yuan-Ze University, Chung-Li, Tao-Yuan, 320, Taiwan, R.O.C.(Tel: 886-3-4638800 ext 7123 Fax: 886-3-4639355 E-mail: chchiu@saturn.yzu.edu.tw)

control gain of the system and  $g(x,t) > 0$  for all  $x$  and  $t$ ;  $u(t) \in R$  is the control input and  $d(t) \in R$  denotes the unknown external disturbance.

The control object is to design a suitable control law for the system (1) so that the state trajectory vector  $x$  can track a desired reference trajectory vector  $x_d = [x_{d1}(t), x_{d2}(t)]^T = [x_d(t), \dot{x}_d(t)]^T$  despite the presence of unknown system dynamics and external disturbance.

In practical application,  $f(x,t)$  can not be exactly obtained in general, and the external disturbance  $d(t)$  is always unknown. Therefore, the IBC should not be precisely obtained for a WIP system. The control law is defined to take the following form:

$$u = u_{AORCMAC} + u_R \tag{2}$$

where  $u_{AORCMAC}$  is the adaptive output recurrent cerebellar model articulation controller (AORCMAC) and  $u_R$  is the robust  $H^\infty$  controller. The AORCMAC is used to copy the IBC, and the robust  $H^\infty$  controller is design to recover the residual approximation error and to achieve  $H^\infty$  tracking performance with desired attenuation level. The design of the RIBTC system is analyzed as follows.

*A. Output recurrent cerebellar model articulation controller*

Here, an output recurrent cerebellar model articulation controller (ORCMAC) is proposed. This ORCMAC is composed of input space  $Q$ , association memory space  $A$ , receptive-field space  $T$ , weight memory space  $W$  and output space  $Y$ . The signal propagation and the basic function in each space are introduced as follows.

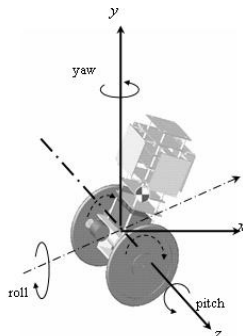

Fig. 1 WIP with its three degree of freedom

1) Input space  $Q$ : For a given  $x = [x_1, x_2, \dots, x_n]^T \in R^n$ , each input state variable  $x_i$  must be quantized into discrete regions (called elements) according to given control space. The number of element,  $n_E$ , is termed as a resolution.

2) Association Memory Space  $A$ : Several elements can be accumulated as a block, the number of blocks,  $n_B$ ,

is usually greater than two. The  $A$  denotes an association memory space with  $n_A$  ( $n_A = n \times n_B$ ) constituents. The Gaussian function is accepted here as the receptive-field basis function, which can expressed as

$$\phi_{ik} = \exp\left[\frac{-(x_{ri} - m_{ik})^2}{v_{ik}^2}\right], \text{for } k = 1, 2, \dots, n_B \tag{3}$$

where  $\phi_{ik}$  is the  $k$ th block of the  $i$ th input  $x_i$  with the mean  $m_{ik}$  and variance  $v_{ik}$ . In addition, the input of this block for discrete time  $N$  can be represented as

$$x_{ri}(N) = x_i(N) + r_i y(N-1) \tag{4}$$

where  $r_i$  is the recurrent weight of the recurrent unit. It is clear that the input of this block contains the memory terms  $y(N-1)$ , which store the past information of the network. By these memory terms, ORCMAC can capture system dynamics and then convert the static CMAC into a dynamic controller. It will achieve food performance for a nonlinear unknown system. This is the apparent difference between the proposed ORCMAC and the conventional CMAC.

3) Receptive-Field Space  $T$ : Areas formed by blocks are called receptive-fields. The number of receptive field,  $n_R$ , is equal to  $n_B$  in this study. The multidimensional receptive-field function is define as

$$b_k = \exp\left[\sum_{i=1}^n \frac{-(x_{ri} - m_{ik})^2}{v_{ik}^2}\right], \text{for } k = 1, 2, \dots, n_a \tag{5}$$

where  $b_k$  is associated with the  $k$ th receptive field. The multidimensional receptive-field function can be expressed in a vector form as

$$\Gamma(q, m, v, r) = [b_1, b_2, \dots, b_k, \dots, b_{n_R}]^T \tag{6}$$

where  $m = [m_{11}, m_{21}, \dots, m_{n1}, \dots, m_{1k}, \dots, m_{nk}]^T \in R^{n \times n_R}$ ,  $v = [v_{11}, v_{21}, \dots, v_{n1}, \dots, v_{1k}, \dots, v_{nk}]^T \in R^{n \times n_R}$  and  $r = [r_1^T, \dots, r_k^T, \dots, r_{n_R}^T]^T \in R^{n \times n_R}$ .

4) Weight Memory Space  $W$ : Every location of  $T$  to a particular adjustable value in the weight memory space can be expressed as

$$w = [w_1, w_2, \dots, w_k, \dots, w_{n_R}]^T \tag{7}$$

where  $w_k$  denotes the connecting weight value of the output associated with the  $k$ th receptive-field. The weight  $w_k$  is initialized from zero and is automatically adjusted during on-line operation.

5) Output Space  $Y$ : The output of CMAC is the algebraic sum of the activated weights in the weight memory, and is expressed as

$$y_o = w\Gamma(x, m, v, r) = \sum_{k=1}^{n_R} w_k b_k \tag{8}$$

*B. Robust intelligent backstepping tracking control*

The design of RIBTC system for the uncertain nonlinear WIP system is described step-by-step as follows:

Step 1: Define the tracking error

$$e_1(t) = x_{d1}(t) - x_1(t) \tag{9}$$

Then the deductive of tracking error can be represented as

$$\dot{e}_1(t) = x_{d2}(t) - x_2(t) \tag{10}$$

The  $x_2(t)$  can be viewed as a virtual control in above equation. Define the following stabilizing function

$$\alpha(t) = k_1 e_1(t) + x_{d2}(t) \tag{11}$$

where  $k_1$  is a positive constant. The first Lyapunov function is chosen as

$$V_1(t) = \frac{1}{2} e_1^2(t) \tag{12}$$

Define

$$e_2(t) = \dot{e}_1(t) + k_1 e_1(t) \tag{13}$$

The deductive of  $V_1(t)$  is

$$\dot{V}_1(t) = -k_1 e_1^2(t) + e_1(t) e_2(t) \tag{14}$$

Then, if  $e_2(t) = 0$ , we would achieve

$$\dot{V}_1(t) = -k_1 e_1^2(t) \leq 0$$

Step 2: The Lyapunov function is chosen as

$$V_2(t) = V_1(t) + \frac{1}{2} e_2^2(t) \tag{15}$$

Since the AORCMAC is utilized to estimate the IBC, so that  $u_{AORCMAC}$  can be written as follows

$$u_{AORCMAC}(x, m, v, r) = y = WT(x, m, v, r) \tag{16}$$

Assume there exists an optimal  $u_{AORCMAC}^*$  to approach the IBC such that

$$u_{IBC}^* = u_{AORCMAC}(x, w^*, m^*, v^*, r^*) + \varepsilon = w^* \Gamma^* + \varepsilon \tag{17}$$

where  $\varepsilon$  is a minimum approximation error,  $w^*, m^*, v^*, \Gamma^*$  and  $r^*$  are optimal parameters of  $w, m, v, \Gamma$  and  $r$ , respectively. However, the optimal  $u_{AORCMAC}^*$  can not be obtained, so that the on-line estimation  $u_{AORCMAC}$  is used to approach the  $u_{IBC}^*$ . From (23), the control law (16) can be rewritten as follows:

$$u = u_{AORCMAC}(x, \hat{w}, \hat{m}, \hat{v}, \hat{r}) + u_R = \hat{w} \hat{\Gamma} + u_R \tag{18}$$

where  $\hat{w}, \hat{m}, \hat{v}, \hat{\Gamma}$  and  $\hat{r}$  are some estimates of the optimal parameters  $w^*, m^*, v^*, \Gamma^*$  and  $r^*$ , respectively. Subtracting (18) from (17), an approximation error  $\tilde{u}$  is defined as

$$\tilde{u} = \tilde{W} \tilde{\Gamma}^* + \tilde{W} \tilde{\Gamma} + \varepsilon - u_R \tag{19}$$

Where  $\tilde{w} = w^* - \hat{w}$  and  $\tilde{\Gamma} = \Gamma^* - \hat{\Gamma}$ . Moreover, the linearization technique is employed to transform the multidimensional receptive-field basis functions into partially linear form so that the expansion of  $\tilde{\Gamma}$  in Taylor

series can be obtained as [18]

$$\tilde{\Gamma} = \begin{bmatrix} \tilde{b}_1 \\ \vdots \\ \tilde{b}_k \\ \vdots \\ \tilde{b}_{n_R} \end{bmatrix} = C^T \tilde{m} + H^T \tilde{v} + R^T \tilde{r} + O_t \tag{20}$$

where  $\tilde{b}_k = b_k^* - \hat{b}_k$ ;  $b_k^*$  is the optimal parameter of  $b_k$ ;  $\hat{b}_k$  is an estimate of  $b_k^*$ ;  $\tilde{m} = m^* - \hat{m}$ ;  $\tilde{v} = v^* - \hat{v}$ ;

$O_t \in R^{n_R}$  is a vector of higher-order terms;  $C = [(\partial b_1 / \partial m) \dots (\partial b_{n_R} / \partial m)]|_{m=\hat{m}} \in R^{n_R \times n_R}$ ,

$H = [(\partial b_1 / \partial v) \dots (\partial b_{n_R} / \partial v)]|_{v=\hat{v}} \in R^{n_R \times n_R}$ ,

$R = [(\partial b_1 / \partial r) \dots (\partial b_{n_R} / \partial r)]|_{r=\hat{r}} \in R^{n_R \times n_R}$

Rewriting (20), it can be obtained that

$$\Gamma^* = \hat{\Gamma} + C^T \tilde{m} + H^T \tilde{v} + R^T \tilde{r} + O_t \tag{21}$$

Substituting (20) and (21) into (19), yields

$$\tilde{u} = \tilde{W} \tilde{\Gamma} + \tilde{W} (C^T \tilde{m} + H^T \tilde{v} + R^T \tilde{r}) + \xi - u_R \tag{22}$$

where  $\xi = \tilde{W} [C^T m + H^T v + R^T r] + W^* O_t + \varepsilon$ ,

Step 3: In order to develop the robust  $H^\infty$  controller, the deductive of  $e_2(t)$  can be expressed as

$$\dot{e}_2(t) = g(x, t) [\tilde{W} \tilde{\Gamma} + \tilde{W} (C^T \tilde{m} + H^T \tilde{v} + R^T \tilde{r}) + \xi - u_R] - e_1(t) - k_2 e_2(t) \tag{23}$$

Step 4: Define the Lyapunov function as

$$V_3(t) = V_2(t) + \frac{1}{2\eta_1} \tilde{W} \tilde{W}^T + \frac{1}{2\eta_2} \tilde{m} \tilde{m}^T + \frac{1}{2\eta_3} \tilde{v} \tilde{v}^T + \frac{1}{2\eta_4} \tilde{r} \tilde{r}^T \tag{24}$$

Where  $\eta_1, \eta_2, \eta_3$  and  $\eta_4$  are positive constants. Taking the derivative of the Lyapunov function (24) and use (23), it is concluded that

$$\begin{aligned} \dot{V}_3(t) = & -E^T KE + \tilde{W} [e_2(t) g(x, t) \hat{\Gamma} - \frac{1}{\eta_1} \dot{\hat{W}}^T] \\ & + [e_2(t) g(x, t) \hat{W} C^T - \frac{1}{\eta_2} \dot{\hat{m}}^T] \tilde{m} \\ & + [e_2(t) g(x, t) \hat{W} H^T - \frac{1}{\eta_3} \dot{\hat{v}}^T] \tilde{v} \\ & + [e_2(t) g(x, t) \hat{W} R^T - \frac{1}{\eta_4} \dot{\hat{r}}^T] + e_2(t) g(x, t) (\xi - u_R) \end{aligned} \tag{25}$$

Step 5: The RIBTC system is designed as (2). The adaptive laws of the AORCMAC are chosen as

$$\dot{\hat{w}} = \eta_1 e_2(t) g(x, t) \hat{\Gamma}^T \tag{26}$$

$$\dot{\hat{m}} = \eta_2 e_2(t) g(x, t) C \hat{w}^T \tag{27}$$

$$\dot{\hat{v}} = \eta_3 e_2(t) g(x, t) H \hat{w}^T \tag{28}$$

$$\dot{\hat{r}} = \eta_4 e_2(t) g(x, t) R \hat{w}^T \tag{29}$$

and the robust  $H^\infty$  controller is chosen as

$$u_R = \frac{(\delta^2 + 1)}{2\delta^2} e_2(t) \quad (30)$$

where  $\delta$  is a positive constant. From (26)-(30), equation (25) can be rewritten as

$$\begin{aligned} \dot{V}_3(t) &= -E^T KE + e_2(t)g(x,t)(\xi - u_R) \\ &= -E^T KE - \frac{1}{2}g(x,t)e_2^2(t) - \frac{1}{2}g(x,t)\left[\frac{e_2(t)}{\delta} - \delta\xi\right]^2 + \frac{1}{2}g(x,t)\delta^2\xi^2 \\ &\leq -\frac{1}{2}g(x,t)e_2^2(t) + \frac{1}{2}g(x,t)\delta^2\xi^2 \end{aligned} \quad (31)$$

Assume  $\xi \in L_2[0, T], \forall T \in [0, \infty)$ . Integrating the above equation from  $t = 0$  to  $t = T$ , yields

$$V_3(T) - V_3(0) \leq -\frac{1}{2} \int_0^T e_2^2(t)g(x,t)dt + \frac{1}{2} \delta^2 \int_0^T g(x,t)\xi^2(t)dt \quad (32)$$

Since  $V(T) \geq 0$ , the above inequality implies the following inequality

$$\frac{1}{2} \int_0^T e_2^2(t)g(x,t)dt \leq V_3(0) + \frac{1}{2} \delta^2 \int_0^T g(x,t)\xi^2(t)dt \quad (33)$$

Using (24), the above inequality is equivalent to the following

$$\begin{aligned} \int_0^T e_2^2(t)dt &\leq E^T(0)E(0) + \frac{1}{\eta_1} \tilde{w}(0)\tilde{w}^T(0) + \frac{1}{\eta_2} \tilde{m}^T(0)\tilde{m}(0) \\ &\quad + \frac{1}{\eta_3} \tilde{v}^T(0)\tilde{v}(0) + \frac{1}{\eta_4} \tilde{r}^T(0)\tilde{r}(0) + \delta^2 \int_0^T \xi^2(t)dt \end{aligned} \quad (34)$$

If the system starts with initial condition  $E(0) = 0$ ,  $\tilde{w}(0) = 0$ ,  $\tilde{m}(0) = 0$ ,  $\tilde{v}(0) = 0$ ,  $\tilde{r}(0) = 0$ , the  $H^\infty$  tracking performance in (34) can be rewritten as

$$\sup_{\xi \in L_2[0, T]} \frac{\|e_2\|}{\|\xi\|} \leq \delta \quad (35)$$

where  $\|e_2\|^2 = \int_0^T e_2^2(t)g_1(x,t)dt$  and

$$\|\xi\|^2 = \int_0^T \xi^2(t)g_1(x,t)dt$$

The attenuation constant  $\delta$  can be specified by the designer to achieve desired attenuation ratio between  $\|e_2\|$  and  $\|\xi\|$ . If  $\delta = \infty$ , this is the case of minimum error tracking control without disturbance attenuation [12]. Then, the desired robust tracking performance in (35) can be achieved for a prescribed attenuation level  $\delta$ . A robust intelligent backstepping tracking control (RIBTC) system is proposed and shown in Fig. 2.

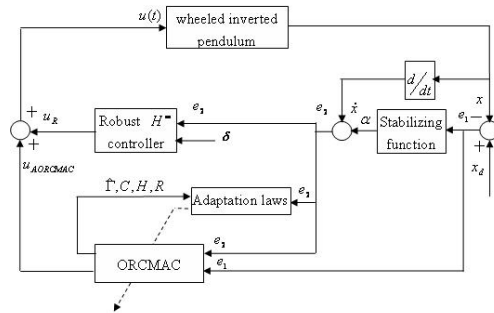

Fig. 2 Block diagram of RIBTC system

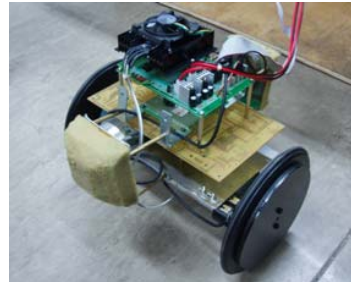

Fig. 3 Wheeled inverted pendulum system

### III. EXPERIMENTAL RESULTS FOR WIP REAL-TIME CONTROL

The WIP in this study is composed of a chassis carrying a 12V dc motor coupled to a gearbox for each wheels, the input/output (I/O) board connects the control system to a personal computer (PC), driver circuit for the motors, the necessary sensors and filter circuit needed to measure pendulum states. Fig. 3 presents a photograph of WIP.

Fig. 4 shows the configuration of the PC-based WIP experimental system. A servo control card is installed in the control PC, which includes multi-channels of digital to analog (D/A) converter, analog to digital (A/D) converter, programmable input/output (PIO) and encoder interface circuits. The measured analog signals are converted to digital values using the A/D converter, which has 12-bit resolution. The proposed RIBTC system is realized in the PC using the "Borland C++ Builder (BCB)" language and its control interval is set at 1.5ms. The whole system is driven using the control voltage from the PWM. The output of the DC-DC converter is a 0-12V PWM square wave (10kHz) with a variable duty cycle.

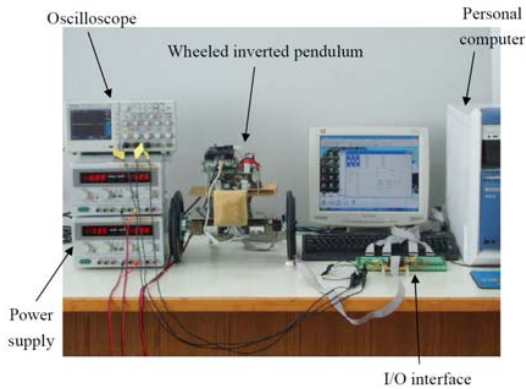
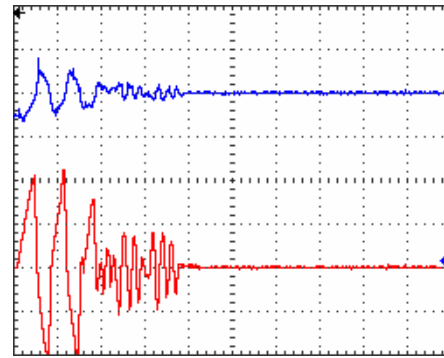

Fig.4 The whole experimental system

In this portion, the AORCMAC used in this experiment is characterized by  $\rho = 4$ ,  $n_E = 5$ ,  $n_B = 8$  and  $n_R = 2 \times 4$ . The receptive-field basis functions are chosen as  $\phi_{ik} = \exp[-(x_{ri} - m_{ik})^2 / v_{ik}^2]$ . The control objective is to let the state trajectory  $x$  tracks the desired reference trajectory  $x_d$ . Moreover, the parameters of the WIP are given as follows: total weight of the WIP is  $7.5 \text{ Kg}$ , moment of inertia of the chassis with respect to the horizontal axis and vertical axis are  $0.0338 \text{ Kg} \cdot \text{m}^2$  and  $0.0269 \text{ Kg} \cdot \text{m}^2$ , lateral distance between wheel and the center of chassis is  $0.15 \text{ m}$  and the height of the WIP from the chassis is  $0.2 \text{ m}$ .

Initial conditions of the AORCMAC control system parameters are chosen as  $r_1 = 0.01$ ,  $r_2 = 0.01$ ,  $m_{i1} = -3$ ,  $m_{i2} = -2$ ,  $m_{i3} = -1$ ,  $m_{i4} = -0.5$ ,  $m_{i5} = 0.5$ ,  $m_{i6} = 1$ ,  $m_{i7} = 2$ ,  $m_{i8} = 3$  and  $v_{ik} = 2$  for all  $i$  and  $k$ . The variable learning-rates were selected as  $k_1 = 1$  and  $\eta_1 = 0.03$ ,  $\eta_2 = \eta_3 = 0.003$ ,  $\eta_4 = 0.01$ . Figure 5 shows the control response of the WIP system with  $x(0) = 45^\circ$ . The tracking responses are plotted in Fig. 5(a) for  $\delta = 1$ ; and Fig. 5(b) for  $\delta = 0.1$ . It depicts that the angle error of the WIP converges quickly and stably by the proposed RIBTC with AORCMAC and  $H^\infty$ . Moreover, the better tracking performance can be achieved as the attenuation constant  $\delta$  is chosen smaller. The effectiveness of the proposed robust control scheme is verified.



(a)

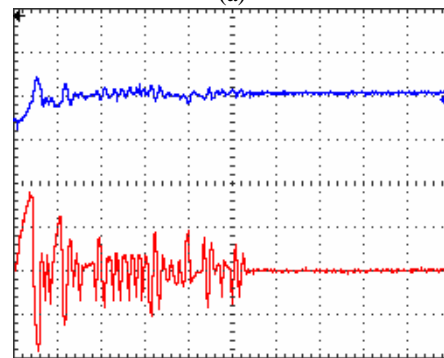

(b)

Fig. 5 Tracking response, experiment results of RIBTC combined with AORCMAC and  $H^\infty$  for the WIP system when  $x_1(0) = 45^\circ$ ,  $x_2(0) = 0$ ,  $x_{d1}(t) = x_{d2}(t) = 0$ : (a) for  $\delta = 1$ ; (b) for  $\delta = 0.1$ .

#### IV. CONCLUSIONS

In this study, a robust intelligent backstepping tracking control (RIBTC) system comprises an adaptive output recurrent cerebellar model articulation controller (AORCMAC) and a robust  $H^\infty$  controller is proposed for WIPs system real-time control. The all adaptation laws of the RIBTC system are derived based on Lyapunov stability analysis, the Taylor linearization technique and  $H^\infty$  control theory, so that the stability of the closed-loop system and  $H^\infty$  tracking performance can be guaranteed. Finally, the proposed RIBTC system is applied to real-time control the WIP system. The experimental results demonstrate the effectiveness of the proposed robust scheme for the WIP system.

#### ACKNOWLEDGMENT

This work was supported by the National Science Council of Taiwan, R.O.C. under the Grant NSC 96-2221-E-155-072.

## REFERENCES

- [1]. T. Ohta, T. Murakami, A stabilization control of bilateral system with time delay by vibration index—application to inverted pendulum control, *IEEE Trans. Ind. Electron.* 56(5) (2009) 1595–1603.
- [2]. R.J. Wai, L.J. Chang, Adaptive stabilizing and tracking control for a nonlinear inverted-pendulum system via sliding-mode technique, *IEEE Trans. Ind. Electron.* 53(2) (2006) 674–692.
- [3]. N. Motoi, T. Suzuki, K. Ohnishi, A bipedal locomotion planning based on virtual linear inverted pendulum mode, *IEEE Trans. Ind. Electron.* 56(1) (2009) 54–61.
- [4]. C.H. Chiu, The design and implementation of a wheeled inverted pendulum using an adaptive output recurrent cerebellar model articulation controller, *IEEE Trans. Ind. Electron.* 57(5) (2010) 1814–1822.
- [5]. F. Grasser, A. D'Arrigo, S. Colombi, A.C. Rufer, JOE: a mobile, inverted pendulum, *IEEE Trans. Ind. Electron.* 39(1) (2002) 107–114.
- [6]. T.J. Ren, T.C. Chen, C.J. Chen, Motion control for a two-wheeled vehicle using a self-tuning PID controller, *Control Engineering Practice* 16(3) (2008) 365–375.
- [7]. S.C. Lin, C.C. Tsai, Development of a self-balancing human transportation vehicle for the teaching of feedback control, *IEEE Trans Educ.* 52(1) (2009) 157–168.
- [8]. C.H. Lee, C.C. Teng, Identification and control of dynamic systems using recurrent fuzzy neural networks, *IEEE Trans. Fuzzy Systems* 8(4) (2000) 349–366.
- [9]. M. Krstic, I. Kanellakopoulos, P.V. Kokotovic, *Nonlinear and Adaptive control Design*. New York: Wiley, 1995.
- [10]. F.J. Lin, P.H. Shen, R.F. Fung, RFNN control for PMLSM drive via backstepping technique, *IEEE Trans. Aerosp. Electron. Syst.* 41 (2005) 620–644.
- [11]. Y.G. Leu, W.Y. Wang, T.T. Lee, Robust adaptive fuzzy-neural controllers for uncertain nonlinear systems, *IEEE Trans. Robot Automat.* 15 (1999) 805–817.
- [12]. B.S. Chen, C.H. Lee,  $H^\infty$  tracking design of uncertain nonlinear SISO system: adaptive fuzzy approach, *IEEE Trans. Fuzzy Syst.* 4 (1996) 32–43.