

A Study on Optimal Determination of Partial Transmission Ratios of Helical Gearboxes with Second-Step Double Gear-Sets

Vu Ngoc Pi

Abstract—In this paper, a study on the applications of the optimization and regression techniques for optimal calculation of partial ratios of helical gearboxes with second-step double gear-sets for minimal cross section dimension is introduced. From the condition of the moment equilibrium of a mechanic system including three gear units and their regular resistance condition, models for calculation of the partial ratios of helical gearboxes with second-step double gear-sets were given. Especially, by regression analysis, explicit models for calculation of the partial ratios are introduced. These models allow determining the partial ratios accurately and simply.

Keywords—Gearbox design, optimal design, helical gearbox, transmission ratio.

I. INTRODUCTION

It is known that in optimal gearbox design, the determination of partial ratios of a gearbox is the most important work. The reason of that is the partial ratios are main factors which affect the size, the mass as well as the gearbox cost. Consequently, optimal calculation of the partial ratios of gearboxes has been subjected to many studies.

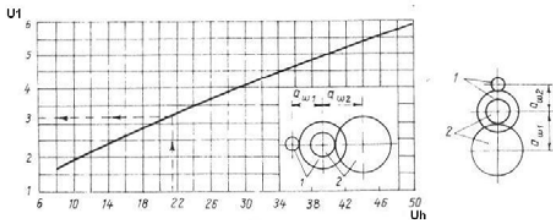

Fig. 1 Determination transmission ratio of the first step of two-step helical gearbox [1]

Up to now, there have been many studies on the determination of two-step helical gearboxes. Kudreavtev V.N. [1] introduced a graph method (see Fig. 1) for determining the transmission ratio of the first step of the gearbox for getting the minimal sum of the center distances. The graph method was also presented by A. N. Petrovski [2], and Trinh Chat [3]. Using a “practical method”, G. Milou et al. [4] found that the weight of the gearbox is minimal if the ratio a_{w2}/a_{w1} is from 1.4 to 1.6 (a_{w1} , a_{w2} are the center distances of the first and the second step, respectively). The authors then gave tabulated optimal values for the partial ratios. Models for optimal determination of the partial ratios were proposed for getting the

minimal gearbox mass [5] or getting the minimal across section of the gearbox [6].

It is clear that, until now, for two-step helical gearboxes there have been many researches on the determination of the partial ratios. However, there have not been studies on optimal calculation of the partial ratios for gearboxes with second-step double gear-sets. This paper presents a study on optimal prediction of partial ratios for helical gearboxes with second-step double gear-sets for getting the minimal cross section dimension.

II. DETERMINATION OF THE DIMENSION OF THE GEARBOX CROSS SECTION

In practice, the cross section dimension of a helical gearbox with second-step double gear-sets is decided by the dimension of A which is determined by the following equation (see Fig. 2):

$$A = L \cdot h \quad (1)$$

In which, h and L are calculated as follows:

$$h = \max(d_{w21}, d_{w22}) \quad (2)$$

$$L = \frac{d_{w11}}{2} + a_{w1} + a_{w2} + \frac{d_{w22}}{2} \quad (3)$$

For the first helical unit, the center distance is determined by:

$$a_{w1} = \frac{d_{w11}}{2} + \frac{d_{w21}}{2} = \frac{d_{w21}}{2} \cdot \left(\frac{d_{w11}}{d_{w21}} + 1 \right) \quad (4)$$

Or we have:

$$a_{w1} = \frac{d_{w21}}{2} \left(\frac{1}{u_1} + 1 \right) \quad (5)$$

Using the same way for the second step we have:

$$a_{w2} = \frac{d_{w22}}{2} \left(\frac{1}{u_2} + 1 \right) \quad (6)$$

Substituting (5) and (6) into (3) with the note that $d_{w11} = d_{w21}/u_1$ we get:

$$L = \frac{d_{w21}}{2} \cdot \left(\frac{2}{u_1} + 1 \right) + \frac{d_{w22}}{2} \cdot \left(\frac{1}{u_2} + 2 \right) \quad (7)$$

In the above equations, u_1, u_2 are transmission ratios, $d_{w11}, d_{w12}, d_{w21}, d_{w22}$ are pitch diameters (mm) and a_{w1}, a_{w2} are center distances (mm) of helical gear units 1 and 2, respectively.

For the first helical unit, the design equation for the pitting resistance is written as follows [7]:

$$\sigma_{H1} = Z_{M1} Z_{H1} Z_{\epsilon1} \sqrt{\frac{2T_{11} K_{H1} \sqrt{u_1 + 1}}{b_{w1} d_{w11}^2 u_1}} \leq [\sigma_{H1}] \quad (8)$$

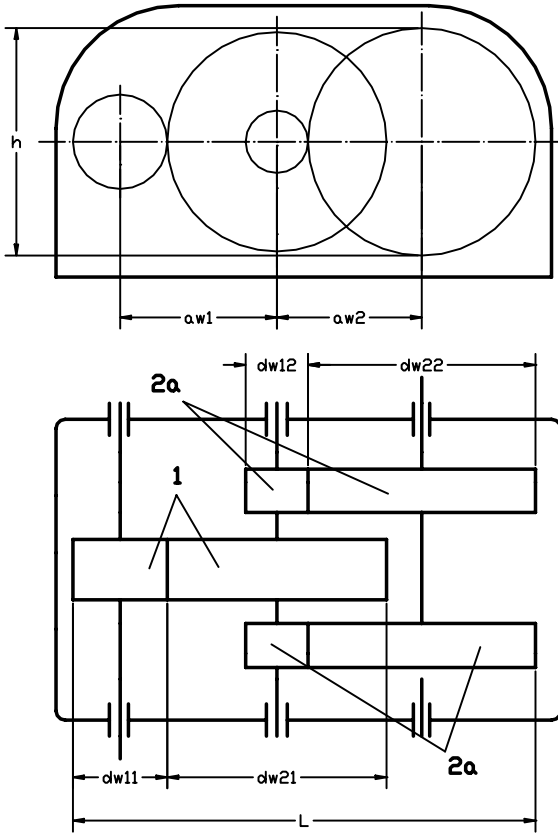

Fig. 2 Calculating schema for helical gearbox with second-step double gear-sets

From (8) we have:

$$[T_{11}] = \frac{b_{w1} \cdot d_{w11}^2 \cdot u_1}{2 \cdot (u_1 + 1)} \frac{[\sigma_{H1}]^2}{K_{H1} \cdot (Z_{M1} \cdot Z_{H1} \cdot Z_{\epsilon1})^2} \quad (9)$$

Where, b_{w1} and d_{w11} are determined as follows:

$$b_{w1} = \psi_{ba1} \cdot a_{w1} = \frac{\psi_{ba1} \cdot d_{w11} \cdot (u_1 + 1)}{2} \quad (10)$$

$$d_{w11} = \frac{d_{w21}}{u_1} \quad (11)$$

Substituting (10) and (11) into (9) we get:

$$[T_{11}] = \frac{\psi_{ba1} \cdot d_{w21}^3 \cdot [K_{01}]}{4 \cdot u_1^2} \quad (12)$$

In the above equation:

$$[K_{01}] = \frac{[\sigma_{H1}]^2}{K_{H1} \cdot (Z_{M1} \cdot Z_{H1} \cdot Z_{\epsilon1})^2} \quad (13)$$

It follows from (12) that d_{w21} can be calculated by:

$$d_{w21} = \left(\frac{4[T_{11}]u_1^2}{\psi_{ba1}[K_{01}]} \right)^{1/3} \quad (14)$$

Calculating in the same way, for the second gear unit we have:

$$d_{w22} = \left(\frac{4[T_{12}]u_2^2}{\psi_{ba2}[K_{02}]} \right)^{1/3} \quad (15)$$

In the above equations, $Z_{M1}, Z_{H1}, Z_{\epsilon1}$ are coefficients which consider the effects of the gear material, contact surface shape, and contact ratio of the first gear unit when calculate the pitting resistance; $[\sigma_{H1}]$ is allowable contact stresses of the first helical gear unit; ψ_{ba1} and ψ_{ba2} are coefficients of helical gear face width of steps 1 and 2, respectively.

The following equation can be found from the condition of moment equilibrium of the mechanic system which includes three gear units and the regular resistance condition of the system:

$$\frac{T_r}{T_{11}} = \frac{[T_r]}{[T_{11}]} = u_1 \cdot u_2 \cdot \eta_{brt}^2 \cdot \eta_o^2 \quad (16)$$

In which, η_{brt} is helical gear transmission efficiency (η_{brt} is from 0.96 to 0.98 [7]); η_o is transmission efficiency of a pair of rolling bearing (η_o is from 0.99 to 0.995 [7]).

Choosing $\eta_{brt} = 0.97$, $\eta_o = 0.992$ and substituting them into (16) we have

$$[T_{11}] = \frac{[T_r]}{0.9259 \cdot u_1 \cdot u_2} \quad (17)$$

With the note that $u_1 = u_h / u_2$ and substituting (17) into (14) we get

$$d_{w21} = \left(\frac{4.3201 \cdot [T_r] \cdot u_h}{\psi_{ba1} \cdot [K_{01}] \cdot u_2^2} \right)^{1/3} \quad (18)$$

For the second helical gear unit we also have:

$$\frac{T_r}{2 \cdot T_{12}} = \frac{[T_r]}{2 \cdot [T_{12}]} = u_2 \cdot \eta_{brt} \cdot \eta_o \quad (19)$$

With $\eta_{brt} = 0.97$ and $\eta_o = 0.992$ Equation 19 becomes

$$[T_{12}] = \frac{[T_r]}{1.9244 \cdot u_2} \quad (20)$$

Substituting (20) into (15) d_{w22} can be calculated as follows:

$$d_{w22} = \left(\frac{2.0786 \cdot [T_r] \cdot u_2}{\psi_{ba2} \cdot [K_{02}]} \right)^{1/3} \quad (21)$$

Substituting (18) and (21) into (7), the length of the gearbox can be determined by the following equation:

$$L = \frac{1}{2} \left(\frac{[T_r]}{[K_{01}]} \right)^{1/3} \cdot \left[\left(\frac{4.3201 \cdot u_h}{\psi_{ba1} \cdot u_2^2} \right)^{1/3} \cdot \left(\frac{2}{u_1} + 1 \right) + \left(\frac{2.0786 \cdot u_2}{\psi_{ba2} \cdot K_{C2}} \right)^{1/3} \cdot \left(\frac{1}{u_2} + 2 \right) \right] \quad (22)$$

Where, $K_{C2} = [K_{02}] / [K_{01}]$.

From (18) and (21), we can rewrite (2) as follows:

$$h = \min \left(\frac{4.3201 \cdot u_h}{\psi_{ba1} \cdot u_2^2}; \frac{2.0786 \cdot u_2}{\psi_{ba2} \cdot K_{C2}} \right) \quad (23)$$

III. OPTIMIZATION PROBLEM AND RESULTS

From Equations (1), (22) and (23), the optimal problem for determining the minimal cross section dimension of the gearbox is expressed as follows:

The objective function is:

$$\min A = f(u_h; u_2) \quad (24)$$

In which, A is determined by (1) and L and h (in Equation 1) are calculated by (22) and (23), respectively.

With the following constraints:

$$\begin{aligned} u_{h \min} &\leq u_h \leq u_{h \max} \\ u_{2 \min} &\leq u_2 \leq u_{2 \max} \\ K_{C2 \min} &\leq K_{C2} \leq K_{C2 \max} \\ \psi_{ba1 \min} &\leq \psi_{ba1} \leq \psi_{ba1 \max} \\ \psi_{ba2 \min} &\leq \psi_{ba2} \leq \psi_{ba2 \max} \end{aligned} \quad (25)$$

To solve the above optimization problem, a computer program was built. The data used in the program were: K_{C2} was from 1 to 1.3, ψ_{ba1} , ψ_{ba2} were from 0.25 to 0.4 [7], u_2 was from 1 to 9 [1]; u_h was from 5 to 40.

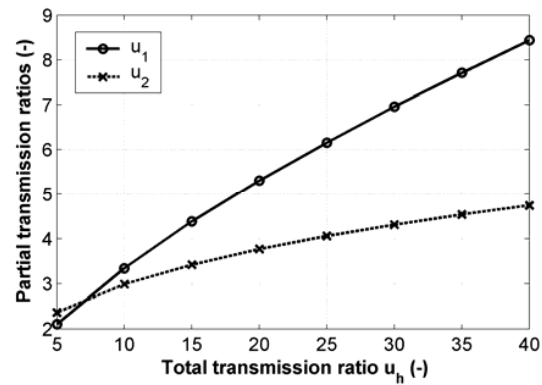

Fig. 3 Partial transmission ratios versus the total transmission ratio

Fig. 3 shows the relation between the partial transmission ratios and the total transmission ratio (calculated with $K_{C2}=1.1$, $\psi_{ba1}=0.3$ and $\psi_{ba2}=0.35$). It can be seen that with the increase of the total ratio u_h the partial ratios increase. In addition, the increase of partial ratio of the first step u_1 is much larger than that of the second step u_2 when the total ratio increases. This is because with the increase of the total ratio u_h , the torque on the output shaft T_r is much larger than that on the driving shaft of the first gear unit T_{11} . Consequently, the partial ratio u_2 has to increase slowly in order to reduce the gearbox length.

From the results of the optimization program, regression analysis was carried out and the following model was determined to calculate the optimal values of the partial ratio of the second step u_2 :

$$u_2 \approx 1.2776 \cdot \sqrt[3]{\frac{K_{C2} \cdot \psi_{ba2}}{\psi_{ba1}} \cdot u_h} \quad (26)$$

The regression model fit quite well with the data (with the coefficient of determination $R^2 = 0.9999$).

Equation 26 is used to calculate the transmission ratio u_2 of the second helical gear unit. After determining u_2 , the transmission ratio of the first gear unit u_1 can be calculated by the following equation:

$$u_1 = \frac{u_h}{u_2} \quad (27)$$

IV. CONCLUSION

The minimal cross section dimension of the helical gearboxes with second-step double gear-sets can be obtained by optimal splitting the total transmission ratio of the gearboxes.

Models for determination of the optimal partial ratios of helical gearboxes with second-step double gear-sets in order to get the minimal cross section dimension of the gearboxes have been proposed.

By introducing explicit models, the partial ratios of the gearboxes can be calculated accurately and simply.

REFERENCES

- [1] V. N. Kudreavtev; I.A. Gierzaves; E.G. Glukharev, *Design and calculus of gearboxes* (in Russian), Mashinostroenie Publishing, Sankt Petersburg, 1971.
- [2] A. N. Petrovski, B.A. Sapiro, N.K. Saphonova, About optimal problem for multi-step gearboxes (in Russian), *Vestnik Mashinostroenie*, No. 10, 1987, pp. 13-14.
- [3] Trinh Chat, Optimal calculation the total transmission ratio of helical gear units (in Vietnamese), *Scientific Conference of Hanoi University of Technology*, 1996, pp. 74-79.
- [4] G. Milou; G. Dobre; F. Visa; H. Vitila, Optimal Design of Two Step Gear Units, regarding the Main Parameters, *VDI Berichte* No 1230, 1996, pp. 227-244.
- [5] Romhild I., Linke H., Gezielte Auslegung Von Zahnradgetrieben mit minimaler Masse auf der Basis neuer Berechnungsverfahren, *Konstruktion* 44, 1992, pp. 229- 236.
- [6] Vu Ngoc Pi, A new method for optimal calculation of total transmission ratio of two step helical gearboxes, *The Nation Conference on Engineering Mechanics*, Hanoi, 2001, pp. 133- 136.
- [7] Trinh Chat, Le Van Uyen, *Design and calculus of Mechanical Transmissions* (in Vietnamese), Educational Republishing House, Hanoi, 1998.