

# A Small-Scale Flexible Test Bench for the Investigation of Fertigation Strategies in Soilless Culture

Giacomo Barbieri

**Abstract**—In soilless culture, the management of the nutrient solution is the most important aspect for crop growing. Fertigation dose, frequency and nutrient concentration must be planned with the objective of reaching an optimal crop growth by limiting the utilized resources and the associated costs. The definition of efficient fertigation strategies is a complex problem since fertigation requirements vary on the basis of different factors, and crops are sensitive to small variations on fertigation parameters. To the best of author knowledge, a small-scale test bench that is flexible for both nutrient solution preparation and precise irrigation is currently missing, limiting the investigations in standard practices for soilless culture. Starting from the analysis of the state of the art, this paper proposes a small-scale system that is potentially able to concurrently test different fertigation strategies. The system will be designed and implemented throughout a three year project started on August 2018. However, due to the importance of the topic within current challenges as food security and climate change, this work is spread considering that may inspire other universities and organizations.

**Keywords**—Soilless culture, fertigation, test bench, small-scale, automation.

## I. INTRODUCTION

**F**OOD security is a fundamental challenge since the global population is exceeding 7.2 billion and is continuously increasing. In 2050, population has been estimated to reach 9.6 billion with more than 60% living in urban areas [1]. The larger growing rate of the population with respect to the regeneration of natural resources and ecosystems, brings to the question on how to feed the world population [2]. Since planetary boundaries of biosphere integrity have been or are soon to be overtaken [3], [4], more efficient and sustainable agricultural systems must be developed [5].

Traditional *soil-based agriculture* allows producing large amount of food but with a negative impact on the environment [6]. It is estimated that 87% of the yearly consumed freshwater is utilized for agriculture [7]. Moreover, high percentages of water and fertilizer are lost in the ground due to leaching. For example, only 30% - 40% of applied nitrogen is used by crops. Movement of the fertilizer inputs can adversely affect natural ecosystems and the water resources they depend on [8]. Traditional agricultural systems are not sustainable on a long run and farmers are under pressure to reduce or eliminate nutrient-laden water discharges to the environment.

*Soilless culture* is a method of growing plants in an inert medium through the use of a solution of mineral nutrients

G. Barbieri is with the Department of Mechanical Engineering, Universidad de Los Andes, Cra. 1 Este No. 19A-40, Bogotá (CO) (e-mail: g.barbieri@uniandes.edu.co).

dissolved in water [9]. Soilless culture is seen as a practice that may help facing current agricultural challenges due to its ability to provide intensive food production in limited areas with more efficient utilization of resources, including non-arable areas such as deserts and cities [10].

In the last decades, soilless culture has grown rapidly. World soilless production has increased from (5,000 – 6,000)ha in the 1980s to (20,000 – 25,000)ha in 2001 [11]. In 2011, world soilless vegetable production has been quantified to about 35,000ha [12]. Eventually, the *Global Market* reached USD 21,203.5 million in 2016 and is expected to register a Compound Annual Growth Rate (CAGR) of 6.5% from 2018 to 2023 [13].

The main bottleneck for the worldwide diffusion of soilless culture is identified in the lack of *standard knowledge* within the cultivation practice [14]. Although more and more literature is available, standard and effective practices are still missing. Therefore, governments, universities and industries should work on filling this gap due to the potential of this agricultural practice.

*Fertigation* is the injection of fertilizers into an irrigation system and is the most critical activity in soilless culture. For example, high salt content in the nutrient solution generates values of osmotic pressure that prevent the absorption of nutrients, while low content affects plant growth and productivity [15]. Frequent irrigations are necessary due to the restricted root volume of the plants [16], but too frequent irrigations increase moisture content in root zone reducing oxygen availability to plants [17]. Moreover, fertigation requirements vary based on numerous factors such as plant species, cultivar, growth stage, utilized substrate, season, and climate conditions. Due to the lack of standard knowledge and the complexity of the problem, test benches are fundamental in order to investigate efficient fertigation strategies.

Current *test benches* allow the concurrent implementation of different fertigation strategies only through the utilization of industrial equipments developed for large-scale applications. Since a reduction in the scale of the equipments would not be profitable for industries, complete small-scale commercial solutions for flexible fertigation are not available in the market limiting the investigations in standard practices for soilless culture. Therefore, a three year research project started on August 2018 at the University of los Andes for the implementation of a small-scale and low-cost system for flexible fertigation.

This article illustrates the planned test bench and is

organized as follows: related works are shown in Section II, while the test bench is described in Section III. Expected results and challenges are reported in Section IV. Eventually, conclusion and future work are presented in Section V.

## II. RELATED WORK

*Fertigation strategy* consists in the determination of both irrigation dose and frequency [18]. *Irrigation dose* depends on [19]:

- *Nutrient solution concentration*: the concentration of the macronutrients (nitrogen, phosphorus, potassium, calcium, magnesium and sulfur) and the micronutrients (iron, boron, copper, manganese, zinc and molybdenum) necessary for the plant growth and development;
- *Substrate*: content of available water in the substrate-container system and substrate volume;
- *Irrigation system*: type of irrigation system such as drip irrigation, subirrigation, flowing, stagnant or mist nutrient solution culture;
- *Crop physiology*: crop response to water status of the substrate.

Whereas, *irrigation frequency* is generally based on intuition or experience without any feedback mechanism leading to not optimal strategies [20]. Time-based control is implemented through rules of thumb based on the experience of the grower [21], [22]. When precise irrigation strategies based on feedback mechanisms are adopted, *Daily Water Use* (DWU) is generally utilized. DWU is the result of the combined loss of water from plant transpiration and substrate evaporation [23]. DWU depends on: (i) the nature of the plant; (ii) plant stage of growth; (iii) weather conditions: light intensity, day length, humidity and temperature; (iv) type of substrate. Three different approaches for precision irrigation can be implemented according to [24]:

- 1) *Set-point control*: sensor readings are used to trigger irrigation. Soil moisture sensors can be utilized to plan irrigation in order to maintain a constant substrate volumetric water content [25]. Another possibility is the measurement of the solar radiation since the DWU is proportional to the daily integrated indoor solar radiation [26];
- 2) *DWU estimation*: experimental and model-based approaches can be used for DWU calculation. In experimental approaches, DWU of container-grown plants can be estimated from the measurements of soil moisture sensors [27] or load cells [28]. In model-based approaches, crop and environmental data are utilized to predict DWU [29], [30];
- 3) *Plant-based methods*: include methods based on direct or indirect measurement of plant water status and those based on plant physiological responses to drought [31], [32].

A flexible test bench for research in soilless culture should be able to individually irrigate each crop with a preset nutrient solution on the basis of the selected strategy. *Fertilizer injection systems* (FISs) make up a nutrient solution by injecting amounts of concentrated stock solutions

into irrigation water [33]. Small-scale FISs can be found commercially as the HI2500 of Hanna Instruments [34]. FISs automate the adjustment of the nutrient solution allowing the maintenance of accurate and stable solutions. Quality of the nutrient solution is monitored through two parameters: (i) *pH*: determines the availability of the various nutrients to the plant [35]; (ii) *electrical conductivity* (EC): indicates the content of nutrients within the solution. Two types of FISs can be implemented according to [36]:

- *Double stock system*: nutrient solution is prepared into a mixing tank in which water and fertilizers are injected. pH and EC are controlled at the mixing tank and acid solution is used to adjust the pH. Two stock concentrated solutions are utilized since precipitation would occur when sulfates and nitrates are mixed at high concentrations;
- *Individual stock system*: individual stock tanks are utilized for each fertilizer providing macronutrients, micronutrients and pH adjustment. These elements are individually injected into the mixing tank. In this way, growers can prepare the nutrient solution by selectively injecting the different fertilizers.

Eventually, *distribution systems* for multiple irrigation lines can be found on a large-scale as the Priva NutriFit and NutriFlex [37]. Whereas, the only small-scale research application has been presented in [38] but does not include a system for the generation of preset nutrient solutions.

Fertigation Manager commercialized from Climate Control is the only large-scale commercial application able to provide multiple distribution lines (up to 46) and nutrient solution concentrations (up to 12) [39]. Whereas, a small-scale system able to individually manage each crop in terms of irrigation dose and frequency, and concentration of the delivered nutrient solution has not been proposed yet.

## III. SMALL-SCALE FLEXIBLE TEST BENCH

Soilless culture can be classified according to how the drainage of the nutrient solution is managed. In an open system, fresh nutrient solution is supplied with each irrigation. Typically, a drain fraction of at least 20-25% is used in order to prevent root zone salinization. Whereas, in closed systems the drainage is collected, filtered, adjusted and re-used for irrigating the same crop. Due to the risk of pathogen contamination, the recirculating nutrient solution must be disinfected. An *open system* is implemented within this project since the recirculation of solutions with different concentrations would increase cost and complexity with low benefits in terms of nutrient solution use efficiency. In fact, a closed system becomes profitable and environmentally sustainable in large-scale commercial applications. Whereas, the planned test bench consists in a research system that will grow just few crops.

A *double stock FIS* for small-scale applications is selected for making up the nutrient solution since individual stock FISs are more expensive and useful mainly for closed systems. Whereas, a *set-point control* fertigation strategy is implemented through moisture sensors since is one of the most

diffused strategies for precise irrigation based on feedback mechanisms.

*Coco coir* is utilized as substrate since [40]: (i) its air/water ratio allows plant roots to grow evenly throughout the substrate; (ii) its high cation exchange capacity traps cations from the solution and releases them at root absorption; (iii) slabs are sold as "ready to use" with drain slits and pre-cut plant holes. Then, *drip irrigation* is selected as irrigation technique since it is the most common practice utilized in large-scale applications [19].

Irrigation water is analyzed since *water quality* is fundamental for crop growing, and nutrient solution must be prepared in accordance with the level of the contained nutrients. The analysis was performed from AGROSAVIA (Colombian Agricultural Research Corporation). All the salts resulted within the acceptable limits defined in [41], with the only exception of the chloride concentration that ideally must be brought to  $0\text{mequiv/L}$ . Moreover, *Total Suspended Solids* (TSS) are removed since would generate obstructions in the tubes and decrease the efficiency of pumps and valves.

Eventually, the planned test bench is dimensioned only for growing two crops. Two crops is the minimum number in order to demonstrate that the system implements different fertigation strategies in terms of irrigation dose and frequency, and concentration of the delivered nutrient solution. However, the system can be scaled up in future.

The planned test bench is subdivided into two modules: (i) Nutrient Solution Module; (ii) Fertigation Module. The strategy utilized for the concurrent management of different nutrient solutions is through the use of two tanks within the Nutrient Solution Module. The nutrient solution is prepared into a mixing tank and then moved to a distribution tank. The Fertigation Module delivers the solution contained in the distribution tank to the crops assigned to that treatment. Meanwhile, a new solution with a different concentration can be prepared into the mixing tank. It can be noticed that this strategy allows the management of an arbitrary number of solutions making the test bench flexible in terms of nutrient solution concentration.

*Nutrient Solution Module* (NSM) is responsible for the make up of nutrient solutions with a preset level of pH and nutrients and is illustrated in Fig. 1. NSM consists of:

- *Filtration Unit*: tap water is collected and two filters respectively reduce chloride and TSS content. Then, filtered water is accumulated into a tank connected to the Recipe Preparation Unit through a pump;
- *Recipe Preparation Unit*: stock solutions contain concentrated nutrients and must be continuously agitated in order to prevent some of the components from settling down. Whereas, the acid tank does not require agitation. Therefore, an air pump is mounted on each fertilizer tank. Then, a feedback loop is implemented in order to make up the nutrient solution. The circulation pump makes the solution flow through EC and pH sensors. EC and pH controllers calculate the error from the target solution and activate peristaltic pumps in order to drip fertilizer and acid directly into the mixing tank. The movement of the nutrient solution from the mixing tank to the distribution

tank is regulated through a valve and the liquid flows by gravity. Eventually, a heater is placed into the distribution tank since the temperature of the nutrient solution in contact with the roots of the plants should be maintained between  $15.5^{\circ}\text{C} - 18^{\circ}\text{C}$  [36].

*Fertigation Module* (FM) is responsible for the implementation of the fertigation strategy. FM is illustrated in Fig. 2 and consists of:

- *Distribution Unit*: each coco coir slab is positioned on a tilted mechanical structure that allows the flowing of the drain solution into a tank. Drainage is individually recollected for correlating each fertigation strategy to the corresponding drain solution and the characteristics of the obtained crop. Eventually, the irrigation pump provides a dose of nutrient solution to the crop selected through the opening of the corresponding valve;
- *Feedback Unit*: a feedback loop is developed for implementing different fertigation strategies. A soil moisture sensor is placed on each slab and a control system is designed in order to maintain a constant substrate volumetric water content.

#### IV. EXPECTED RESULTS AND CHALLENGES

The purpose of this article is the definition of a small-scale test bench able to individually manage each crop in terms of irrigation dose and frequency, and concentration of the delivered nutrient solution. The planned system can individually irrigate each crop through the utilization of valves within the Distribution Unit. Then, irrigation frequency can be set through the implementation of different fertigation strategies. Eventually, multiple nutrient solutions can be managed through the utilization of a mixing and a distribution tank. The system is planned only for two crops, two nutrient solutions and two fertigation strategies but can be scaled up.

The illustrated test bench presents three main challenges that will be faced throughout the project:

- *Mechatronic integration*: system consists of several mechatronic components that must be integrated and coordinated. Moreover, it must be able to manage both nominal and exceptional behavior. Even if the individual components are simple, complexity will be due to the successful implementation of a working and stable solution;
- *Small-scale*: design of small-scale research applications is challenging due to the required precision. In fact, the same absolute error in a controlled variable corresponds to a larger relative error on a small-scale application with respect to a large-scale one. Moreover, experiments are valuable only if the system is precise and replicable. Therefore, either open loop strategies or additional feedback loops will be designed in order to implement a precise system. In particular, precision and repeatability are required in the operations of: (i) preparation of the nutrient solution both in terms of quantity and quality; (ii) delivering of the irrigation dose; (iii) utilization of the selected sensors: frequent calibration will be necessary in order to have a reliable information.

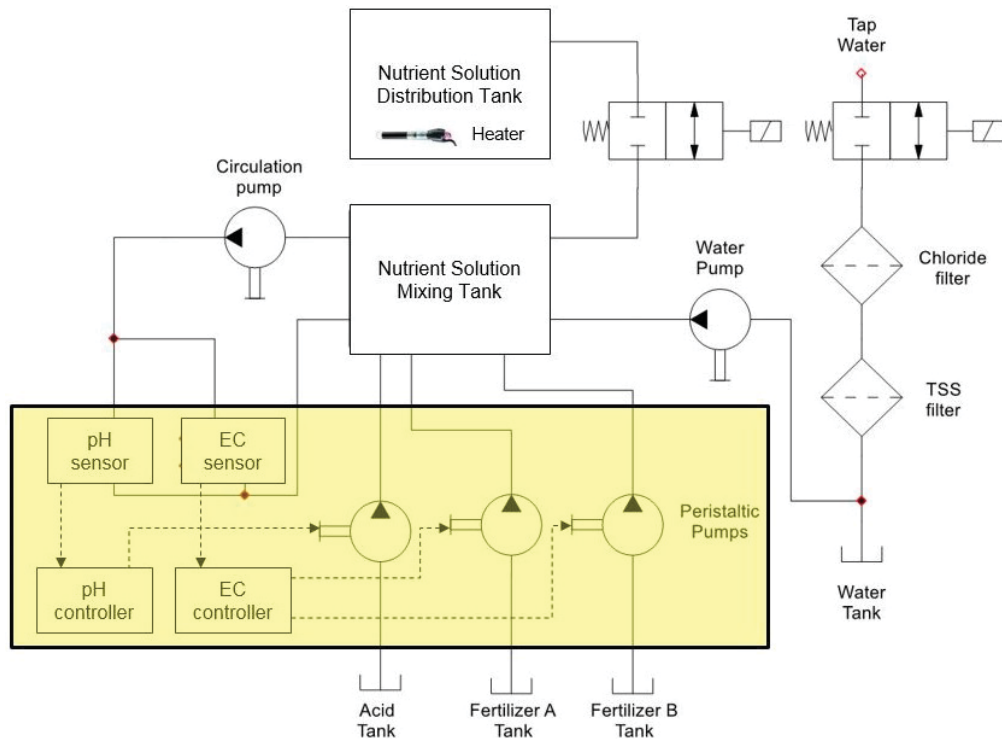

Fig. 1 Schematic of the Nutrient Solution Module. The yellow box illustrates a double stock Fertilizer Injection Machine

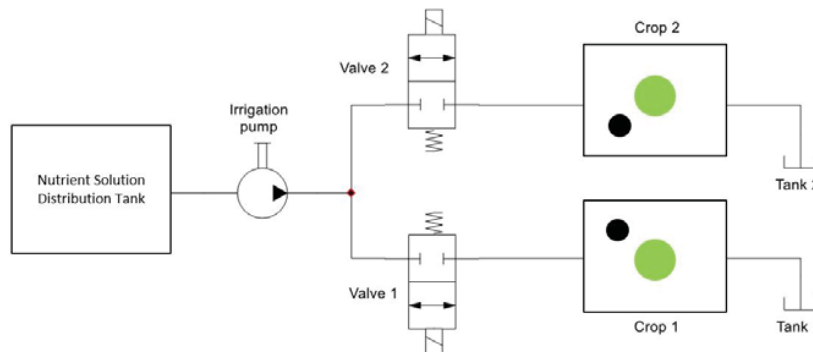

Fig. 2 Schematic of the Fertigation Module. The green circle represents a crop, while the black one a moisture sensor

- *Low-cost*: generally precision and cost are directly proportional quantities. However, a precise and low-cost application is desirable in order to be replicable and for contributing to the generation of standard practices in soilless culture. Trade-off analyses will be continuously performed throughout the design process for the development of a low-cost solution with the required precision.

## V. CONCLUSION AND FUTURE WORK

A small-scale test bench potentially able to individually manage each crop in terms of irrigation dose and frequency, and concentration of the delivered nutrient solution has been presented within this article. A three-year research project

started on August 2018 at the University of los Andes for the design and implementation of the described system.

Eventually, future work is presented. Soilless cultures are generally enclosed in greenhouse-type structures for: (i) providing temperature and humidity control; (ii) decreasing evaporative water loss; (iii) reducing disease and pest infestations [42]. Therefore, the implemented test bench will be integrated within an automated greenhouse allowing the investigation of fertigation strategies in accordance with the climate conditions.

## ACKNOWLEDGMENT

Author would like to thank the Universidad of los Andes for providing the necessary resources for implementing the

project, and the company Saenz Fety for the technical support within the planning phase.

## REFERENCES

- [1] UN, "World urbanization prospects: The 2014 revision-highlights," Department of Economic and Social Affairs, Tech. Rep., 2014. (Online). Available: <https://esa.un.org/unpd/wup/publications/files/wup2014-highlights.pdf>.
- [2] B. Delaide, G. Delhaye, M. Dermience, J. Gott, H. Soyeyurt, and M. H. Jijakli, "Plant and fish production performance, nutrient mass balances, energy and water use of the paff box, a small-scale aquaponic system," *Aquacultural Engineering*, 2017.
- [3] K. V. Ragnarsdóttir, H. Sverdrup, and D. Koca, "Challenging the planetary boundaries 1: Basic principles of an integrated model for phosphorous supply dynamics and global population size," *Applied Geochemistry*, 2011.
- [4] H. U. Sverdrup and K. V. Ragnarsdóttir, "Challenging the planetary boundaries 2: Assessing the sustainable global population and phosphate supply, using a systems dynamics assessment model," *Applied Geochemistry*, 2011.
- [5] R. V. Tyson, D. D. Treadwell, and E. H. Simonne, "Opportunities and challenges to sustainability in aquaponic systems," *HortTechnology*, 2011.
- [6] D. Tilman, K. G. Cassman, P. A. Matson, R. Naylor, and S. Polasky, "Agricultural sustainability and intensive production practices," *Nature*, 2002.
- [7] R. R. Kumar and J. Y. Cho, "Reuse of hydroponic waste solution," *Environmental Science and Pollution Research*, 2014.
- [8] W. J. Mitsch and J. G. Gosselink, "Wetlands," Wiley, New York, 2007.
- [9] J. B. Jones Jr, *Hydroponics: a practical guide for the soilless grower*. CRC press, 2016.
- [10] S. Grillas, M. Lucas, E. Bardopoulou, S. Sarafopoulos, and M. Voulgari, "Perlite based soilless culture systems: current commercial application and prospects," *Acta Horticulturae*, 2001.
- [11] S. Carruthers, "Hydroponics as an agricultural production system," *Pract. Hydrop. Greenh.*, 2002.
- [12] G. Hickman, "Greenhouse vegetable production statistics: a review of current data on the international production of vegetables in greenhouses," *Cuesta Roble greenhouse consultants, Mariposa, CA*, 2011.
- [13] M. Intelligence, "Hydroponics market - segmented by type, crop type, and geography - growth, trends and forecasts," Tech. Rep., 2018. (Online). Available: <https://www.mordorintelligence.com/industry-reports/hydroponics-market>.
- [14] A. Hussain, K. Iqbal, S. Azim, P. Mahato, and A. Negi, "A review on the science of growing crops without soil (soilless culture)-a novel alternative for growing crops," *International Journal of Agriculture and Crop Sciences*, 2014.
- [15] D. Savvas, G. Ntatsi, and H. C. Passam, "Plant nutrition and physiological disorders in greenhouse grown tomato, pepper and eggplant," *The European Journal of Plant Science and Biotechnology*, 2008.
- [16] S. P. Dubik, D. T. Krizek, and D. P. Stimart, "Influence of root zone restriction on mineral element concentration, water potential, chlorophyll concentration, and partitioning of assimilate in spreading euonymus," *Journal of plant nutrition*, 1990.
- [17] F.-G. Schröder and J. H. Lieth, "Irrigation control in hydroponics," 2002.
- [18] D. Savvas, G. Gianquinto, Y. Tuzel, and N. Gruda, "Soilless culture," in *Good agricultural practices for Greenhouse Vegetable Crops: Principles for Mediterranean Climate Areas*. Food and Agriculture Organization of the United Nations (FAO), 2013, ch. 12.
- [19] A. Pardossi, G. Carmassi, C. Diara, L. Incrocci, R. Maggini, and D. Massa, "Fertigation and substrate management in closed soilless culture," *Pisa: University of Pisa*, 2011.
- [20] B. E. Belayneh, J. D. Lea-Cox, and E. Lichtenberg, "Costs and benefits of implementing sensor-controlled irrigation in a commercial pot-in-pot container nursery," *HortTechnology*, 2013.
- [21] L. Bacci, P. Battista, and B. Rapi, "An integrated method for irrigation scheduling of potted plants," *Scientia horticulturae*, 2008.
- [22] H. Jones, "Irrigation scheduling-comparison of soil, plant and atmosphere monitoring approaches," in *V International Symposium on Irrigation of Horticultural Crops 792*, 2006.
- [23] H. H. Tyler, S. L. Warren, and T. E. Bilderback, "Reduced leaching fractions improve irrigation use efficiency and nutrient efficacy," *Journal of Environmental Horticulture*, 1996.
- [24] J. D. Lea-Cox, W. L. Bauerle, M. W. van Iersel, G. F. Kantor, T. L. Bauerle, E. Lichtenberg, D. M. King, and L. Crawford, "Advancing wireless sensor networks for irrigation management of ornamental crops: An overview," *HortTechnology*, 2013.
- [25] S. E. Burnett and M. W. van Iersel, "Morphology and irrigation efficiency of gaura lindheimeri grown with capacitance sensor-controlled irrigation," *HortScience*, 2008.
- [26] M. K. Meric, "Effects of nutrition systems and irrigation programs on tomato in soilless culture," *Agricultural Water Management*, 2001.
- [27] C. Cornejo, D. Z. Haman, and T. H. Yeager, "Evaluation of soil moisture sensors, and their use to control irrigation systems for containers in the nursery industry," in *2005 ASAE Annual Meeting*. American Society of Agricultural and Biological Engineers, 2005.
- [28] M. Raviv, J. H. Lieth, and R. Wallach, "The effect of root-zone physical properties of coir and uc mix on performance of cut rose (cv. kardinal)," in *World Congress on Soilless Culture: Agriculture in the Coming Millennium 554*, 2000.
- [29] R. G. Allen, L. S. Pereira, D. Raes, M. Smith *et al.*, "Crop evapotranspiration-guidelines for computing crop water requirements-fao irrigation and drainage paper 56," *Fao, Rome*, 1998.
- [30] J. Kim, M. W. van Iersel, and S. E. Burnett, "Estimating daily water use of two petunia cultivars based on plant and environmental factors," *HortScience*, 2011.
- [31] H. G. Jones, "Irrigation scheduling: advantages and pitfalls of plant-based methods," *Journal of experimental botany*, 2004.
- [32] J. Cifre, J. Bota, J. Escalona, H. Medrano, and J. Flexas, "Physiological tools for irrigation scheduling in grapevine (vitis vinifera l.): An open gate to improve water-use efficiency?" *Agriculture, Ecosystems & Environment*, 2005.
- [33] A. P. Papadopoulos, E. M. Labbate, and N. Liburdi, "Computerized fertilizer injection system," 1993, uS Patent 5, 184, 420.
- [34] H. Instruments, "Mini fertilizer injection systems." (Online). Available: <https://hannainst.com/mini-fertilizer-injection-system.html>.
- [35] H. B. Sprague, "Hunger signs in crops," *Soil Science*, 1964.
- [36] H. M. Resh, *Hydroponic food production: a definitive guidebook for the advanced home gardener and the commercial hydroponic grower*. CRC Press, 2016.
- [37] Priva, "Nutrifit and nutriflex." (Online). Available: <https://www.priva.com/products/nutriline>.
- [38] K. S. Nemali and M. W. van Iersel, "An automated system for controlling drought stress and irrigation in potted plants," *Scientia Horticulturae*, 2006.
- [39] C. Control, "Fertigation manager." (Online). Available: <http://www.climatecontrol.com/fertigation-manager>.
- [40] C. Olympos, "Soilless media under protected cultivation rockwool, peat, perlite and other substrates," in *Symposium on Soil and Soilless Media under Protected Cultivation in Mild Winter Climates 323*, 1992.
- [41] C. De Krijg, W. Voogt, and R. Baas, *Nutrient solutions and water quality for soilless cultures*. Research Station for Floriculture and Glasshouse Vegetables, Naaldwijk Office, 1999.
- [42] M. H. Jensen and A. J. Malter, *Protected agriculture: a global review*. World Bank Publications, 1995.



**Giacomo Barbieri** received the master degree in Mechanical Engineering (2012) and Ph.D. in System Engineering (2016) from the University of Modena and Reggio Emilia. The master degree and the Ph.D were in collaboration with Tetra Pak Packaging Solutions. From June 2016, he joined the Universidad de los Andes before as Postdoctoral Researcher and then as Assistant Professor. His main expertise is industrial automation and mechatronics.