

A Proof for Bisection Width of Grids

Kemal Efe and Gui-Liang Feng

Abstract—The optimal bisection width of r -dimensional $N \times \dots \times N$ grid is known to be N^{r-1} when N is even, but when N is odd, only approximate values are available. This paper shows that the exact bisection width of grid is $\frac{N^r-1}{N-1}$ when N is odd.

Keywords—Grids, Parallel Architectures, Graph Bisection, VLSI Layouts.

I. INTRODUCTION

OPTIMAL bisections are needed for optimal VLSI layouts [3]. Let $n(A)$ denote the number of edges which must be cut to remove A vertices from the $N \times \dots \times N$ grid when N is odd. We show that

$$n(A) \geq \frac{2\min\{A, N^r - A\}}{N - 1}$$

Then, several open problems posed by Leighton [?] (page 269, problems 1.277, 1.279, and 1.281) follow as special cases. For example, grid bisection (problem 1.277) is a special case where $A = \frac{N^r-1}{2}$, and the lower bound is obtained as $\frac{N^r-1}{N-1}$. We show that this value also serves as an upper bound by showing a cut which satisfies this lower bound. Exact values for the other two open problems are obtained easily from this result.

II. DEFINITIONS

The following is the central problem addressed in this paper: Given the r -dimensional $N \times \dots \times N$ grid, find two connected subgraphs G and H such that (1) G contains $\frac{N^r-1}{2}$ vertices and H contains $\frac{N^r+1}{2}$ vertices; (2) If we delete all edges, one vertex of which is in G and the other vertex is in H , then there is no path from G to H ; (3) the number of deleted edges is minimum.

It is useful to think that the nodes of G are colored in black and the nodes of H are colored in white. A vertex X in the r -dimensional grid is denoted by a vector $X = x_r \dots x_1$ where $0 \leq x_i \leq N - 1$, for $i = 1 \dots r$, and N is odd. Let $d(X, Y) = \sum_{i=1}^r |x_i - y_i|$ be the Hamming distance between X and Y . If $d(X, Y) = 1$ then X and Y are said to be *adjacent*. It is easily seen that if $d(X, Y) = 1$ then there is exactly one i such that $|x_i - y_i| = 1$, and that for $j \neq i$, $x_j = y_j$. If (X, Y) is such an edge, and $y_i = x_i + 1$, then we say that the edge (X, Y) is a positive edge of X in dimension i and a negative edge of Y in dimension i . We will be interested in all positive (or negative) edges

Kemal Efe is with the Center for Advanced Computer Studies, University of Louisiana, Lafayette, LA 70504, email: efe@cacs.louisiana.edu

Gui-Liang Feng is with the Center for Advanced Computer Studies, University of Louisiana, Lafayette, LA 70504, email: glf@cacs.louisiana.edu

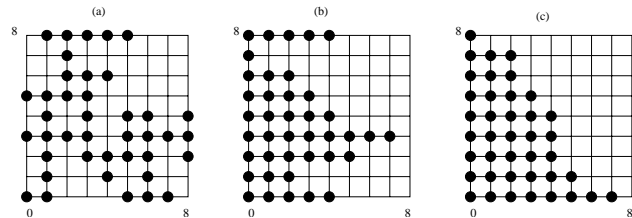

Fig. 1. The initial distribution of black nodes is shown in (a). All other intersection points contain white nodes (not shown). The situation after compressing in the horizontal dimension is shown in (b). The canonical form is shown in (c).

which connect a black vertex to a white vertex. Then we use “ j ’s positive cut edges” to refer to all edges of the type (X, Y) in G where X is a black vertex, Y is a white vertex, $y_j = x_j + 1$, and for all $i \neq j$, $x_i = y_i$. Similarly, we use “ j ’s negative cut edges” to refer to all edges of the type (X, Y) where again X is a black vertex, Y is a white vertex, $y_j = x_j - 1$, and for all $i \neq j$, $x_i = y_i$.

Given an arbitrary distribution of black and white vertices in the grid which satisfies the required numbers, we divide the black vertices into disjoint sets, one set for each hyperplane in each dimension. For example $S_k^{(j)}$ is a set where the subscript $k = 0, \dots, N - 1$ denotes the hyperplane of interest, and j denotes the dimension orthogonal to that hyperplane. The set $S_k^{(j)}$ contains all black vertices of the form $x_r \dots x_{j+1} k x_{j-1} \dots x_1$. For each of these sets, we define a “projective image” as follows: We say that the set $P_k^{(j)}$ is a “projective image” of $S_k^{(j)}$, where $P_k^{(j)}$ is obtained from $S_k^{(j)}$ by changing the j th symbol into a don’t care symbol “*” for every vertex in it. For example, if $x_r \dots x_{j+1} k x_{j-1} \dots x_1 \in S_k^{(j)}$, then $x_r \dots x_{j+1} * x_{j-1} \dots x_1 \in P_k^{(j)}$. Although $S_k^{(j)}$ and $S_{k'}^{(j)}$ have no common elements for $k \neq k'$, $P_k^{(j)}$ and $P_{k'}^{(j)}$ may have some common elements. For example, $x_r \dots x_{j+1} * x_{j-1} \dots x_1$ is a projective image of $x_r \dots x_{j+1} k x_{j-1} \dots x_1$, as well as of $x_r \dots x_{j+1} (k + 1) x_{j-1} \dots x_1$. These sets are shown below for the example in Figure 1.(a).

The $S_k^{(j)}$ sets for Figure 1.(a) are:

$$\begin{aligned} S_0^{(1)} &= \{00, 30, 50\} \\ S_1^{(1)} &= \{01, 11, 21, 31, 41, 51, 81\} \\ &\cdot \\ &\cdot \\ S_7^{(1)} &= \{07, 37\} \\ S_8^{(1)} &= \{28, 38, 48\} \\ S_0^{(2)} &= \{00, 01, 05, 06, 07\} \\ &\cdot \end{aligned}$$

$$S_8^{(2)} = \{81, 82, 83, 84, 85\}$$

The $P_k^{(j)}$ sets for (a) are:

$$P_0^{(1)} = \{0*, 3*, 5*\}$$

$$P_1^{(1)} = \{0*, 1*, 2*, 3*, 4*, 5*, 8*\}$$

$$P_7^{(1)} = \{0*, 3*\}$$

$$P_8^{(1)} = \{2*, 3*, 4*\}$$

$$P_0^{(2)} = \{*0, *1, *5, *6, *7\}$$

$$P_8^{(2)} = \{*1, *2, *3, *4, *5\}$$

III. CANONICAL BISECTIONIONS

In this section we introduce the concept of canonical bisections. First, we need to establish some preliminary facts. Let

$$P_+^{(j)} = \left\{ \bigcup_{k=0}^{N-2} P_k^{(j)} \right\} - P_{N-1}^{(j)} \quad (1)$$

and

$$P_-^{(j)} = \left\{ \bigcup_{k=1}^{N-1} P_k^{(j)} \right\} - P_0^{(j)}. \quad (2)$$

Lemma 1: $|P_+^{(j)}| \leq$ the number of all the j 's positive cut edges, and $|P_-^{(j)}| \leq$ the number of all the j 's negative cut edges.

Proof: Trivially follows from definition of $P_k^{(j)}$. ■

Since the total number of cut edges C is equal to $\sum_{j=1}^r$ (the number of j 's positive edges + the number of j 's negative edges), from Lemma 1, we have the following.

Lemma 2: $C \geq \sum_{j=1}^r (|P_+^{(j)}| + |P_-^{(j)}|)$.

Now we define "compression" as follows.

Definition 1: Let $x_r \cdots x_{j+1} k_\lambda x_{j-1} \cdots x_1 \in G$ for $\lambda = 1, 2, \dots, \mu$, where $0 \leq k_1 < k_2 < \dots < k_\mu \leq N-1$. Let G' be the set of all the $x_r \cdots x_{j+1} \ell x_{j-1} \cdots x_1 \in G$ for $\ell = 0, 1, \dots, \mu-1$. The transformation from G to G' is called a compression in dimension j .

Intuitively, a compression in dimension j sorts the vertices along the straight lines of dimension j so that the black vertices move to smaller index values of dimension j and the white vertices move to the larger index values of dimension j . This process yields the G' subgraph from G . This is illustrated in Figure 1.(b). It can be easily checked from this figure that $|G'| = |G|$. Also, the number of cut edges induced by G' is not more than the number of cut edges induced by G . For the general case we have the following lemma.

Lemma 3: Let G' be the new subgraph obtained from G by compression in some dimension j . Then the number

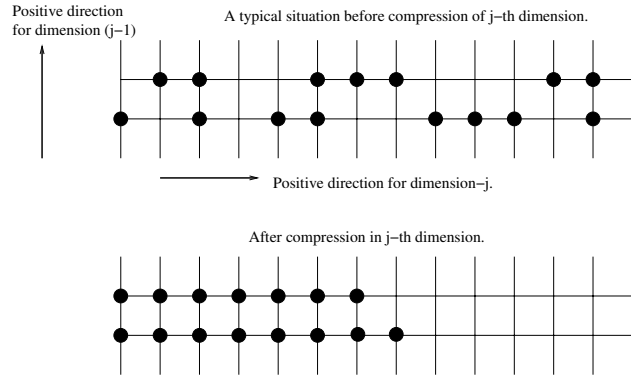

Fig. 2. The effect of compression in j th dimension on the number of cut edges in the $(j-1)$ st dimension.

of cut edges induced by $G \geq$ number of cut edges induced by G' .

Proof: It is easily seen that $|G| = |G'|$, because a compression does not change the number of vertices. First, consider the number of cut edges in dimension j . Let p be the number of black vertices on a dimension- j line. If $p < N$ then there is at least one cut edge on this line before compression, whereas after compression there is exactly one cut edge. Applying this reasoning to every dimension- j line, we conclude that compression along dimension j doesn't increase the number of cut edges in dimension j .

For other dimensions, we just consider the number of cut edges in dimension $(j-1)$; other dimensions can be considered similarly. Let n_1 denote the the number of positive cut edges in dimension $(j-1)$ induced by G . Let n_2 denote the number of edges not cut in dimension $(j-1)$ induced by G . Let n_3 denote the number of negative cut edges in dimension $(j-1)$ induced by G . Thus, there are a total of $n_1 + n_3$ cut edges in dimension $(j-1)$.

After a compression in dimension j (see Figure 2), we still have the original n_2 edges not cut in dimension $(j-1)$, plus possibly more uncut edges. When $n_1 \geq n_3$, there are $n_1 - n_3$ induced $(j-1)$'s positive cut edges but there are no $(j-1)$'s negative cut edges; thus the number of uncut edges increases to $n_2 + n_3$. Conversely, if $n_1 \leq n_3$, there are $n_3 - n_1$ negative cut edges but no positive cut edges; and the number of uncut edges increases to $n_2 + n_1$. Thus we observe that the number of cut edges can only decrease under compression. ■

Let G^* be the graph which is obtained from G by a series of compressions in all dimensions $r, \dots, 2, 1$. We call G^* the canonical bisection form of G . From the above lemmas, we have thus proven the following theorem.

Theorem 1: Suppose G^* is a canonical bisection form induced by G , then the number of cut edges induced by G^* is equal to or less than that of G .

As an example, the canonical bisection form G^* corresponding to G in Figure 1.(a) is shown in Figure 1.(c). Due to Theorem 1, to find the minimum bisection width of grids, we will only consider canonical bisection forms

in this paper.

Canonical bisections satisfy a number of useful properties: Let G^* be a canonical bisection in r -dimensional grid with $A = |G|$, and let $A_i = |S_i^{(j)}|$ for some dimension j . Then,

Property 1: For all $j = 1, 2, \dots, r$, if $x_r \cdots x_j \cdots x_1 \in G^*$ and $x_j > 0$ then $x_r \cdots (x_j - 1) \cdots x_1 \in G^*$. That is, for G^* ,

$$P_0^{(j)} \supseteq P_1^{(j)} \supseteq \dots \supseteq P_{N-2}^{(j)} \supseteq P_{N-1}^{(j)}, \quad (3)$$

It follows from this property that

$$A_0 \geq A_1 \geq \dots \geq A_{N-2} \geq A_{N-1}. \quad (4)$$

and each $S_k^{(j)}$ is in the canonical bisection form in its r -dimensional grid. Moreover,

$$A = \sum_{i=0}^{N-1} A_i.$$

for any dimension j .

Before we present the second property, we first recall equations (1) and (2), and note that for a canonical bisection form $\bigcup_{k=0}^{N-2} P_k^{(j)} = P_0^{(j)}$, and, $\bigcup_{k=1}^{N-1} P_k^{(j)} = P_1^{(j)}$. Then, (1) and (2) become

$$P_+^{(j)} = P_0^{(j)} - P_{N-1}^{(j)}$$

and

$$P_-^{(j)} = P_1^{(j)} - P_0^{(j)}.$$

Due to (3) we have $P_-^{(j)} = \phi$. Therefore $|P_+^{(j)}|$ represents the total number of cut edges in dimension j , and $|P_+^{(j)}| = A_0 - A_{N-1}$.

From these observations we have the following property:

Property 2: Let $n(A)$ be the number of cut edges induced by G^* . Then:

$$n(A) = \sum_{i=0}^{N-1} n(A_i) + A_0 - A_{N-1}. \quad (5)$$

Here $n(A_i)$ is the number of cut edges for the i th hyperplane in dimensions other than j . The difference $A_0 - A_{N-1}$ is the number of cut edges in dimension j .

IV. LOWER BOUND

We have the following theorem as the main result of this paper:

Theorem 2: $n(A) \geq \frac{2 \min\{A, N^r - A\}}{N-1}$ for odd N .

Proof: Without loss of the generality, let us consider the case of $A \leq \frac{N^r - 1}{2}$. Then, claim of the theorem simplifies to

$$n(A) \geq \frac{2A}{N-1}. \quad (6)$$

It can be easily checked that the theorem is true for $r = 1$, i.e. $1 \geq \frac{2N-1}{N-1}$. Assuming that the theorem is true for r dimensions, we prove that it is also true for $(r + 1)$ dimensions.

From the induction hypothesis, we have

$$n(A_i) \geq \frac{2 \min\{A_i, N^r - A_i\}}{N-1}. \quad (7)$$

Let there be a p such that $0 \leq p$ and

$$A_0 \geq A_1 \geq \dots \geq A_p \geq \frac{N^r + 1}{2},$$

$$\text{and, } \frac{N^r - 1}{2} \geq A_{p+1} \geq \dots \geq A_{N-1}. \quad (8)$$

Using (7) in (5) we have

$$n(A) \geq \frac{2(\sum_{i=0}^p (N^r - A_i)) + 2 \sum_{i=p+1}^{N-1} A_i}{N-1} + A_0 - A_{N-1}. \quad (9)$$

To prove the theorem, we need to show that the right hand side of (9) is greater than or equal to the right hand side of (6). The right hand side of (6) can be written as

$$\frac{2A}{N-1} = \frac{2 \sum_{i=0}^p A_i + 2 \sum_{i=p+1}^{N-1} A_i}{N-1}$$

thus we need to show that

$$\frac{2(\sum_{i=0}^p (N^r - A_i)) + 2 \sum_{i=p+1}^{N-1} A_i}{N-1} + A_0 - A_{N-1} \geq \frac{2 \sum_{i=0}^p A_i + 2 \sum_{i=p+1}^{N-1} A_i}{N-1}.$$

By simplification this is equivalent to

$$2(p+1)N^r + (N-1)A_0 - (N-1)A_{N-1} \geq 4 \sum_{i=0}^p A_i, \quad (10)$$

where

$$\sum_{i=0}^p A_i + \sum_{k=p+1}^{N-1} A_k = A \leq \frac{N^r + 1}{2}, \quad (10.1)$$

$$A_0 \geq \dots \geq A_p \geq \frac{N^r + 1}{2} > \frac{N^r - 1}{2} \geq A_{p+1} \geq \dots \geq A_{N-1}. \quad (10.2)$$

Then, we need to prove that (10) holds under (10.1) and (10.2). In fact, it suffices to consider a special canonical form where (see Figure 3):

$$A_0 = \dots = A_p > A_{p+1} = \dots = A_{N-2} \geq A_{N-1}. \quad (10.3)$$

That is, we replace condition (10.2) by condition (10.3). To see why, let the right hand side of (10) be $C = 4 \sum_{i=0}^p A_i$. Then, for a given p and its associated C , we can construct a new canonical bisection from with the same p , such that $A_i^* = \frac{C}{p+1}$ for $i = 0, \dots, p$, and $A_{N-1}^* = A_{N-1}$. In this new canonical form (10) corresponds to

$$2(p+1)N^r + (N-1)A_0^* - (N-1)A_{N-1}^* \geq 4 \sum_{i=0}^p A_i^* = 4(p+1)A_0^*,$$

which represents the case shown in Figure 3 (actually in this case we will also have $A_\ell^* = \frac{\sum_{k=p+1}^{N-2} A_k}{N-p-2}$ for $\ell = (p+1), \dots, (N-2)$, however A_ℓ^* values are irrelevant

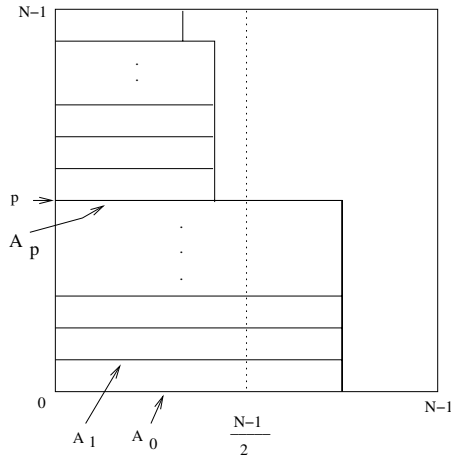

Fig. 3. Canonical special form.

since they don't appear in (10)). If we prove that (10) is correct under (10.3), then the correctness of (10) trivially follows under (10.2) since $A_0 \geq A_0^*$, and $A_{N-1} = A_{N-1}^*$.

Thus, we rewrite (10) as:

$$2(p+1)N^r + (N-1)A_0 - (N-1)A_{N-1} \geq 4(p+1)A_0, \quad (11)$$

where

$$(p+1)A_0 + (N-2-p)A_{N-2} + A_{N-1} = A \leq \frac{N^{r+1}-1}{2}, \quad (11.1)$$

$$A_0 \geq \frac{N^r+1}{2} > \frac{N^r-1}{2} \geq A_{N-2} \geq A_{N-1}. \quad (11.2)$$

For cases 1 and 2 below, we assume that $A = \frac{N^{r+1}-1}{2}$. Other values of A will be considered in Case 3.

Case 1: $A_{N-1} = 0$.

In this case (11) is reduced to

$$2(p+1)N^r + (N-1)A_0 \geq 4(p+1)A_0, \quad (12)$$

For this case we will consider two subcases:

Subcase 1.a:

$$(p+1)A_0 \leq \frac{N^r(N-1)}{2}. \quad (13)$$

In this subcase, since for all $\alpha, \beta \geq 0$, $\alpha + \beta \geq 2\sqrt{\alpha\beta}$, using $\alpha = 2(p+1)N^r$ and $\beta = (N-1)A_0$, in the left hand side of (12) we have

$$2(p+1)N^r + (N-1)A_0 \geq 2\sqrt{2(p+1)N^r(N-1)A_0}.$$

Rewriting the right hand side of this as

$$4\sqrt{(p+1)A_0 \frac{N^r(N-1)}{2}}$$

and using (13)

$$\begin{aligned} 4\sqrt{(p+1)A_0 \frac{N^r(N-1)}{2}} &\geq 4\sqrt{(p+1)A_0(p+1)A_0} \\ &= 4(p+1)A_0. \end{aligned}$$

Thus, (12) is true.

Subcase 1.b:

$$\frac{N^r(N-1)}{2} < (p+1)A_0 \leq \frac{N^{r+1}-1}{2} \quad (14)$$

In this subcase, since $\frac{N^r+1}{2} \leq A_0 \leq N^r$, (14) can be rewritten as

$$\frac{N^r(N-1)}{2N^r} \leq p+1 \leq \frac{N^{r+1}-1}{N^r+1},$$

thus $\frac{N-1}{2} \leq p+1$.

We analyze this case under three subcases.

Subcase 1.b.i: When $A_0 = N^r$, since $\frac{N+1}{2}N^r > \frac{N^{r+1}-1}{2}$ it follows that $(p+1) < \frac{N+1}{2}$, but since $\frac{N-1}{2} \leq p+1$, it must be that $(p+1) = \frac{N-1}{2}$, or $(N-1) = 2(p+1)$. Using this in the left hand side of (12) we obtain

$$2(p+1)N^r + (N-1)A_0 = 2(p+1)A_0 + 2(p+1)A_0 = 4(p+1)A_0.$$

Therefore (12) is true.

Subcase 1.b.ii: When $A_0 = \frac{N^r+1}{2}$, since from (14) we assumed $(p+1)A_0 > \frac{N^r(N-1)}{2}$, then

$$(p+1) > \frac{N^r(N-1)}{2} \cdot \frac{2}{N^r+1} = (N-1) - \frac{N-1}{N^r+1}.$$

Thus $p+1 > N-2$. On the other hand, since $p+1$ cannot be larger than $N-1$, we have $p+1 = N-1$. Using these in the left hand side of (12), we have

$$\begin{aligned} 2(N-1)N^r + (N-1) \cdot \frac{N^r+1}{2} \\ = (N-1) \left(\frac{5}{2}N^r + \frac{1}{2} \right) \\ > 4(N-1) \left(\frac{N^r+1}{2} \right) = 4(p+1)A_0. \end{aligned}$$

Thus, (12) is again true.

Subcase 1.b.iii: It now remains to show that (12) is true when $\frac{N^r+1}{2} < A_0 < N^r$. Define $x = A_0$, $y = p+1$, $a = 2N^r$, and $b = N-1$. Using these in (12), we obtain

$$ay + bx \geq 4xy.$$

We already showed in Cases 1.b.i and 1.b.ii that this is true when $x = N^r$ and $x = \frac{N^r+1}{2}$. Note also that $xy = (p+1)A_0$, and this can be written as $xy = c$, with $c = xy$ being a parameter between

$$\frac{N^r(N-1)}{2} \leq xy \leq \frac{N^{r+1}-1}{2}.$$

The shaded region in Figure 5 is the area of interest for Case 1.b.iii; the two bounding points of $x = N^r$ and $x = \frac{N^r+1}{2}$ were already shown above. The question faced here is that, between these points, for all other values of $c = xy$ is it also true.

Note that (12) can be written as

$$z(x, y) = ay + bx - 4xy \geq 0 \quad (15)$$

and we need to show that this is true. This function is in the form shown in Figure 4. To prove that (15) is true, it suffices to show that $z(x, y)$ curve is above the xy plane in the shaded region of Figure 5.

By using $y = c/x$ in (15), we obtain

$$z\left(x, \frac{c}{x}\right) = \frac{ac}{x} + bx - 4c.$$

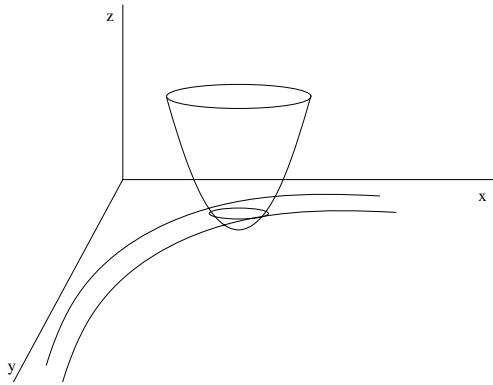

Fig. 4. Plot of equation (15)

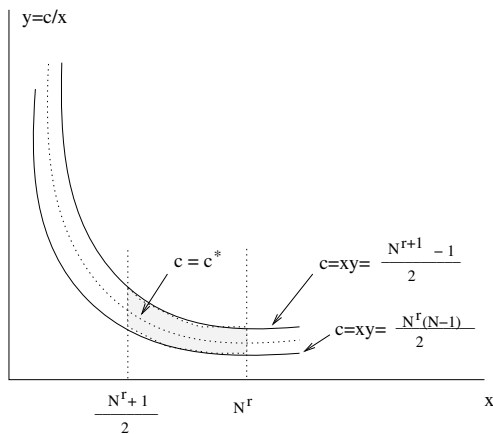

Fig. 5. Shaded region represents the area of interest in Case 1.b.iii.

Choose any fixed value $c = c^*$ in the range

$$\frac{N^r(N-1)}{2} \leq c^* \leq \frac{N^{r+1}-1}{2}$$

Then we have

$$z^*(x, \frac{c^*}{x}) = \frac{ac}{x} + bx - 4c^*$$

This has derivative

$$\frac{\delta z^*}{\delta x} = -\frac{ac}{x^2} + b$$

which is equal to zero when $x = \sqrt{\frac{ac^*}{b}} = \sqrt{\frac{2N^r c^*}{N-1}}$, and the function $z^*(x, \frac{c^*}{x})$ is minimum at this value of x (for $x > 0$). Since we assumed above that $c^* \geq \frac{N^r(N-1)}{2}$, using this, and after simplification, we obtain $x \geq N^r$. This implies that the minimum value of (15) is on the right of the $x = N^r$ point in Figure 5. Since Case 1.b.i already proved that (12) is true for $x = A_0 = N^r$, implying that (15) is true when $x = A_0 = N^r$, then it follows that (12) is true when $\frac{N^{r+1}}{2} < A_0 < N^r$.

Combining these three subcases, in Case 1.b, theorem is true.

Combining the cases 1.a and 1.b, in Case 1, theorem is true.

Case 2: $A_{N-1} \neq 0$.

By the same reason which allowed us to write (10.3) for (10.2), we can assume here that $A_{N-2} = A_{N-1}$ in (11) without loss of generality. In this case, (11) becomes

$$2(p+1)N^r \geq (4p+5-N)A_0 + (N-1)A_{N-1}, \quad (16)$$

where

$$(p+1)A_0 + (N-1-p)A_{N-1} = \frac{N^{r+1}-1}{2}, \quad (16.1)$$

$$A_0 \geq \frac{N^{r+1}}{2} > \frac{N^r-1}{2} \geq A_{N-1}. \quad (16.2)$$

Then we can write (16) as

$$f(A_0, p+1, A_{N-1}) = 2(p+1)N^r - (4p+5-N)A_0 - (N-1)A_{N-1} \geq 0,$$

Subcase 2.a: $A_0 = N^r$.

In this subcase, since $(p+1)A_0 < \frac{N^{r+1}-1}{2}$, we have $p+1 \leq \frac{N-1}{2}$.

Subcase 2.a.i: If $p+1 = \frac{N-1}{2}$, from equation (16.1) we obtain $A_{N-1} = \frac{N^r-1}{N+1}$, and from (8) we have

$$n(A) \geq \frac{N+1}{2}n(A_{N-1}) + N^r - \frac{N^r-1}{N+1}. \quad (17)$$

It suffices to show that the right hand side of (17) is greater than $\frac{N^{r+1}-1}{N-1}$, directly proving Theorem 2 when $A = \frac{N^{r+1}-1}{2}$. Note that

$$\frac{N+1}{2}n(A_{N-1}) + N^r - \frac{N^r-1}{N+1} \geq \frac{N^{r+1}-1}{N-1}$$

simplifies to

$$n(A_{N-1}) \geq \frac{4(N^r-1)}{N^2-1} \cdot \frac{N}{N+1},$$

or, by using $A_{N-1} = \frac{N^r-1}{N+1}$, we obtain

$$n(A_{N-1}) \geq \frac{4A_{N-1}}{N-1} \cdot \frac{N}{N+1}.$$

Let $a = \sqrt[r]{r!A_{N-1}}$. Then, $A_{N-1} = \frac{a^r}{r!}$ and by induction on r with $A_{N-1} = \frac{N^r-1}{N+1}$, a lower bound for $n(A_{N-1})$ is obtained as $n(A_{N-1}) \geq \frac{a^{r-1}}{(r-1)!}$. Using this, it remains to show that

$$\frac{a^{r-1}}{(r-1)!} \geq \frac{4A_{N-1}}{N-1} \cdot \frac{N}{N+1}.$$

Multiplying both sides of this by a/r , after simplification we obtain

$$r \geq \frac{4Na}{N^2-1}. \quad (18)$$

By using $a = \sqrt[r]{r!A_{N-1}}$ in (18), with $A_{N-1} \leq \frac{N^r-1}{N+1}$ the reader can check that it is also true for all values of $r, N > 0$. Thus, in subcase 2.a.i, the theorem is true.

Subcase 2.a.ii: $p+1 = 1$.

Note that $p+1 > 0$, since $p+1 = 0$ implies that $A_0 < N^r$, contradicting with the basic assumption of subcase

2.a. If $p + 1 = 1$, then from (15.1) we obtain $A_{N-1} = \frac{N^r(N-2)-1}{2(N-1)}$. Using this in (15), we have

$$2N^r \geq (5 - N)N^r + (N - 1) \frac{N^r(N - 2) - 1}{2(N - 1)}$$

We can ignore the (-1) in the numerator of the second term on the right hand side as it will strengthen the claim of this inequality. After simplification, we obtain $N \geq \frac{N+4}{2}$, which is true when $N > 3$.

Subcase 2.a.iii: $1 < p + 1 < \frac{N-1}{2}$.

Using $A_0 = N^r$ in (16), we obtain

$$A_{N-1} \leq \frac{N^r}{N-1}((N-1) - 2(p+1)). \quad (19)$$

Note that this is in the form $y \leq b - ax$, with $y = A_{N-1}$, and $x = p + 1$, with a and b constants.

The proofs of cases 2.a.i and 2.a.ii implies that (19) is true when $p+1 = \frac{N-1}{2}$ and when $p+1 = 1$. Between these two values A_{N-1} decreases linearly as $(p+1)$ increases. Therefore, in case 2.a.iii theorem is true.

Combining the cases 2.a.i, 2.a.ii, and 2.a.iii, in Case 2.a theorem is true.

Case 2.b: $A_0 = \frac{N^r+1}{2}$.

In this case, as before, we have $\frac{N-1}{2} \leq (p+1) \leq N-1$.

If $(p+1) = \frac{N-1}{2}$ we have $A_{N-1} = \frac{N^r-1}{2}$. Using these in (17) we obtain

$$(N-1)N^r - (2(N-1) - N+1) \frac{N^r+1}{2} - (N-1) \frac{N^r-1}{2} \geq 0$$

where the left hand side evaluates to 0 and (17) is true.

If $p+1 = N-1$, then again since $A = \frac{N^r+1}{2}$, we have $A_{N-1} = \frac{N^r-N}{2}$, and by using these, (17) is trivially true.

Combining the cases 1 and 2, the theorem is true when $A = \frac{N^r+1}{2}$, corresponding to the dark shaded area in Figure 5.

Case 3: $A < \frac{N^r+1}{2}$.

To consider this case, first note that (11) is equivalent to

$$N^r \geq 2A_0 + \frac{N-1}{2(p+1)}(A_{N-1} - A_0). \quad (20)$$

Here the left hand side is constant (i.e. independent of A), and is shown above to be larger than the right hand side when $A = \frac{N^r+1}{2}$. We now show that it is also larger than the right hand side when $\frac{N^r+1}{2} < A < \frac{N^r+1}{2}$. The case for $A \leq \frac{N^r+1}{2}$ is included in subcase 2.a.i above, and the theorem is true for all values of A .

To prove the case for $\frac{N^r+1}{2} < A < \frac{N^r+1}{2}$, we define the corresponding problem as follows: prove that

$$N^r \geq 2A_0^* + \frac{N-1}{2(p^*+1)}(A_{N-1}^* - A_0^*). \quad (21)$$

where $A_0^* = A_0$, $A_{N-1}^* = A_{N-1}$, $p^* \leq p$, and $A_{j^*} \leq A_j$ for $(p^*+1) \leq j \leq (N-2)$. Comparing the right hand sides of (20) and (21), we need to show that

$$2A_0 + \frac{N-1}{2(p+1)}(A_{N-1} - A_0) \geq 2A_0^* + \frac{N-1}{2(p^*+1)}(A_{N-1}^* - A_0^*)$$

which will imply that the theorem is true because the left hand side is known to be less than N^r . After simplifying this, we have

$$\frac{A_{N-1} - A_0}{p+1} \geq \frac{A_{N-1}^* - A_0^*}{p^*+1}$$

which is true since $(A_{N-1} - A_0) = (A_{N-1}^* - A_0^*)$, both of $(A_{N-1} - A_0)$ and $(A_{N-1}^* - A_0^*)$ are negative, and $(p^*+1) \leq (p+1)$.

This completes the proof of Theorem 2. ■

As a result, we have the following lower bound.

Corollary 1: Bisection width of r -dimensional $N \times \dots \times N$ grid is at least $\frac{N^r-1}{N-1}$ when N is odd.

V. UPPER BOUND

Theorem 3: Let G_1 be any subgraph of the r -dimensional $N \times \dots \times N$ grid where N is odd and $|G_1| = \frac{N^r-1}{2}$. There exists a canonical bisection form G_1^* obtained from G_1 with $n(|G_1^*|) = \frac{N^r-1}{N-1}$.

Proof: This bisection is obtained as follows. Consider the black vertices of the grid as 0 and the white vertices as 1. Thus G_1 contains all the 0's and no 1's. Then sort these 0's and 1's in the "snake-order."

Once the sorting is completed, all of the 0's are at the lowest $\frac{N-1}{2}$ hyperplanes (orthogonal to r th dimension), and all of the 1's are at the highest $\frac{N-1}{2}$ hyperplanes. The "middle" hyperplane contains half 0's and half 1's (within a difference of one).

Now cut every edge (X, Y) of the grid where X contains a 0 and Y contains a 1. Due to snake-order, all of the straight lines in dimension r are cut. There are N^{r-1} straight lines in this dimension. Since the "middle" hyperplane contains half 0's and half 1's (within a difference of one), and it is also sorted in the snake-order, then all of the dimension- $(r-1)$ lines in it are also cut. There are N^{r-2} dimension- $(r-1)$ lines in the middle hyperplane. Continuing recursively, the total number of cut edges is

$$N^{r-1} + N^{r-2} + \dots + 1 = \frac{N^r - 1}{N - 1},$$

This completes the proof. ■

VI. CONCLUSIONS

Optimal bisections for 2-dimensional grids with "holes" have been studied in [2]. For regular grids in multiple dimensions with odd N , the problem has been open for at least 25 years since the publication of [?].

This paper shows that when N is odd, $n(A) \geq \frac{2 \min\{A, N^r - A\}}{N-1}$ edges must be cut to separate A vertices from the grid. Optimal bisections for torus and other related networks can be easily obtained from this result.

References

- [1] F. T. Leighton, "Introduction to Parallel Algorithms and Architectures: Arrays, Trees, Hypercubes," Morgan Kaufmann, 1992.
- [2] C. H. Papadimitrou and M. Sideri, "The Bisection Width of Grid Graphs," Theory of Computing Systems, Vol. 29, No. 2, March 1996, pp. 97-110.
- [3] C. D. Thompson, "A Complexity Theory for VLSI," PhD thesis, Carnegie-Mellon University, August 1980.