

A Numerical Study of the Effect of Side-Dump Angle on Fuel Droplets Sizing in a Three-Dimensional Side-Dump Combustor

M. Mojtahedpoor, M. M. Doustdar

Abstract—A numerical study on the effect of side-dump angle on fuel droplets sizing and effective mass fraction have been investigated in present paper. The mass of fuel vapor inside the flammability limit is named as the effective mass fraction. In the first step we have considered a side-dump combustor with dump angle of 0° (across the cylinder) and by increasing the entrance airflow velocity from 20 to 30, 40 and 50 (m/s) respectively, the mean diameter of fuel droplets sizing and effective mass fraction have been studied. After this step, we have changed the dump angle from 0° to 30° , 45° and finally 60° in direction of cylinder and also we have increased the entrance airflow velocity from 20 up to 50 (m/s) with the amount of growth of 10(m/s) in each step, to examine its effects on fuel droplets sizing as well as effective mass fraction. With rise of entrance airflow velocity, these calculations are repeated in each step too. The results show, with growth of dump-angle the effective mass fraction has been decreased and the mean diameter of droplets sizing has been increased. To fulfill the calculations a modified version of KIVA-3V code which is a transient, three-dimensional, multiphase, multicomponent code for the analysis of chemically reacting flows with sprays, is used.

Keywords—Side-Dump combustor, Droplets sizing, Side-Dump angle, KIVA-3V

I. INTRODUCTION

THE integral ramjet system to be employed in advanced missiles is characterized by severe volume constraints, so dump combustors are usually chosen for use in volume limited ramjets and ducted rocket missile designs. As we know, the conventional flame holder and combustor liners are not contained in such dump combustors, and the recirculation regions formed by the sudden enlargement of the area between the inlet ducts and the combustion chamber severely affect the flame stabilization. Generally, dump combustors can be grouped into two types--coaxial and side-dump combustors--by the characteristics of the air-breathing systems. In coaxial dump combustors, both air and gaseous fuel are conducted into the combustion chamber through the dome plate, and the flow field is mostly axisymmetric so that the axisymmetric. In side-dump combustors, gaseous fuel from a gas generator is

injected through the dome plate and the air stream is supplied through the inlet ducts attached to the combustor periphery. Therefore, the flow field and the fuel-air mixing process in side-dump combustors will be more complicated than that in coaxial dump combustors, in which both air and fuel streams do not bend to a large extent as they flow from the inlet ports to the combustion chamber.

The researches, which focus on the fuel/air mixing phenomena or reactive flows, are very rare in open literatures either by using numerical methods [1-4] and most of the previous investigations on the flow fields in a side-dump combustor considered only one component fluid [5,6]. For simplifying the problem, nearly all of the previous relevant numerical studies took the cylindrical combustion chamber itself only as the computational domain. In these studies, the distributions of velocities on the side entrance of the cylindrical combustion chamber, which are required as boundary conditions for computations, were simplified and assigned based on some artificial assumptions. However, since the realistic flow situation as fluids enter the cylindrical combustion chamber from the side entrance is very complicated, the simplified boundary conditions can hardly be accurate. Consequently, the parametric study of relevant design factors of the system based on the analysis adopting only the cylindrical combustion chamber itself as computational domain will be imprecise. In a recent study, Doustdar et al [7] first included the side-inlet ducts as well as the cylindrical combustion chamber itself as an integral computational domain to investigate the complete flow fields in both of the side-inlet ducts and the cylindrical combustion chamber. In the study, fuel injection positions in the side-inlet duct were varied to see the effects on fuel/air mixing phenomena in the whole flow fields.

In the present study, with changing the entrance airflow velocity and side-dump angle, the effective mass fraction and the mean diameter of propulsive droplets have numerically investigated as well as the flow fields in different side-dump angle are shown and compared.

II. NUMERICAL MODELING

A. The computer program

The computer program, used in this work is a KIVA-3V based code. The numerical procedure used in this simulation is based on the discrete-droplet model (DDM). In this model, the entire spray is represented by finite numbers of groups of particles. Each particle represents a number of droplets of

M. Mojtahedpoor, Ph.D student of aerospace engineering, He is one of the members of Young Researchers Club, Science and Research Branch, Islamic Azad University, Tehran, Iran (e-mail: mojtahedpoor@gmail.com, cell phone number: +989158063855)

M. M. Doustdar is with Associate professor in mechanical engineering department, Imam Hossein University, Tehran, Iran. (e-mail: mmdoustdar@yahoo.com)

identical size, velocity and temperature. A Lagrangian formulation is used to track the motion and transport of particles through the flow field and an Eulerian formulation is used to solve the governing equations for the gas phase. The gas phase solution procedure is based on the ALE (arbitrary Lagrangian-Eulerian) finite volume method. Implicit differencing is used for the terms associated with pressure wave propagation and for all the diffusion terms. Explicit differencing is used to calculate convection terms. To avoid the restriction of time step by the Courant stability condition, the convection calculation is sub-cycled. The turbulent law of the wall is employed to calculate wall heat transfer and boundary layer drag. We have used a standard version of the $k-\epsilon$ turbulence model. The effects of droplets on the gas phase are considered by designating proper source terms in the gas phase conservation equations. The particles and gas interact by exchanging mass, momentum and energy. For assigning droplet properties at injection or anywhere in downstream, a probability concept is applied. A Monte Carlo sampling technique is used to calculate droplet properties. More description is well documented in [8]. We have carried out necessary modifications regarding an unconfined two-phase cloud. We have also introduced a multi-nozzle modeling to simulate the dispersal of the fuel from cylindrical containers.

B. Mesh Generation

The KIVA-3 formulation is based on (x,y,z) Cartesian coordinates. Rather than being confined to one logical block of cells in (i,j,k) space to encompass the entire region to be modeled, however, the geometry of a KIVA-3 mesh is composed of any arbitrary number of logical blocks that are patched together in a completely seamless fashion.

With regard to the injection initial conditions, the dimensions of the computation domain are selected. As the injection velocity, or fuel total mass, increases, a larger domain of computation should be considered.

C. Boundary Conditions

In this study we have considered a cylinder with dual opposite curved side-inlet duct. The air flow comes into the cylinder from these side-inlet ducts and after mixing with injected fuel, it exhausted from end of combustor. The length of combustor is 40[cm] and the diameter is 10[cm]. The side-dump angle is changed from 0° to 30° , 45° and finally 60° in direction of cylinder. The specification of mentioned mesh has been shown in Figure 1. Also as an example, a side-dump combustion with dump-angle of 30° is shown in figure 2.

As the boundary conditions, we have applied "Specified inflow" for the entrance air flow of secondary region and "pressure outflow" for the exit area of this region. About the main region, as the boundary conditions for the entrance the "pressure inflow" and for the exit area of this region "pressure outflow" have specified, the boundary condition of walls have been considered "solid" also.

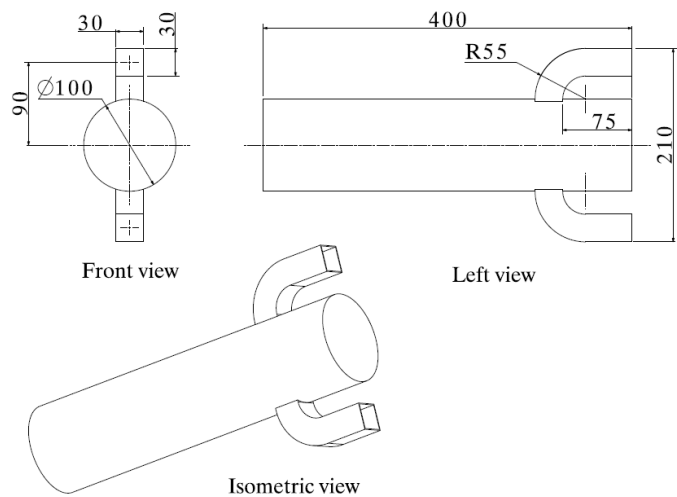

Fig. 1 Geometry and dimension of the simulated combustor model

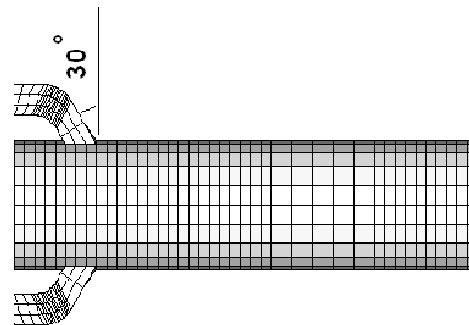

Fig. 2 A side-dump combustor with dump angle of 30°

TABLE I
INITIAL CONDITIONS

	Temperature [K]	Velocity [m/s]	Pressure [atm]	Initial Sauter radius [cm]	Mass flow [g/s]
Fuel droplets	300	30		0.01	15
Entrance airflow	300	20 up to 50	1		

D. Solving Pattern

The time of solving has considered 1 second and the time of fuel injection is 0.02 second after solving beginning in due to the fact that the flow in cylinder becomes pervasive. All of calculations have been done by KIVA-3V code which modified for this purpose.

III. RESULTS

This study is divided into 4 session. In first session we have considered a side-dump combustor with dump angle of 0° (across the cylinder) and by increasing the entrance airflow velocity from 20 to 30, 40 and 50 (m/s) correspondingly, the mean diameter of droplets sizing and effective mass fraction have been investigated. In the step 2 up to 4, the dump angle has changed from 0° to 30°, 45° and 60° respectively and previous calculations have been repeated. The results of this investigation have been illustrated in tables 2 to 5.

TABLE II
THE MEAN DIAMETER OF PROPULSIVE DROPLETS SIZING IN DUMP ANGLE OF 0 [DEGREE]

	Entarncce airflow velocity [m/s]			
	20	30	40	50
Mean diameter (µm)	44.6	31.6	28.4	19.6
Effective mass fraction (percent)	94	91.1	69.5	50.3

TABLE III
THE MEAN DIAMETER OF PROPULSIVE DROPLETS SIZING IN DUMP ANGLE OF 30 [DEGREE]

	Entarncce airflow velocity [m/s]			
	20	30	40	50
Mean diameter (µm)	49.7	37.5	31.2	27.1
Effective mass fraction (percent)	79.7	64.5	56.4	43.7

TABLE IV
THE MEAN DIAMETER OF PROPULSIVE DROPLETS SIZING IN DUMP ANGLE OF 45 [DEGREE]

	Entarncce airflow velocity [m/s]			
	20	30	40	50
Mean diameter (µm)	59.9	50.4	42.1	33.1
Effective mass fraction (percent)	43.1	33.7	27.2	22.8

TABLE V
THE MEAN DIAMETER OF PROPULSIVE DROPLETS SIZING IN DUMP ANGLE OF 60 [DEGREE]

	Entarncce airflow velocity [m/s]			
	20	30	40	50
Mean diameter (µm)	104.4	71.2	57.8	40.5
Effective mass fraction (percent)	27.1	20.2	15.9	12.42

IV. DISCUSSION

A. Propulsive droplets sizing

According to the tables 2 to 5, with increase of dump angle from 0° up to 60° in cylinder direction, the mean diameter of propulsive droplets sizing has increased, also with increase of entrance airflow velocity this quantity has decreased. In below some comparing graphs have been given.

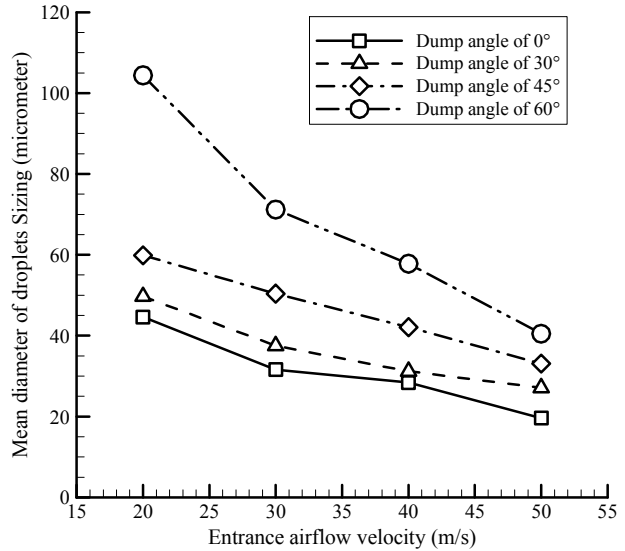

Fig. 3 The variation of mean diameter in different entrance airflow velocity

Considering figures 3 and 4, by growth of entrance airflow velocity from 20 to 30 (m/s) the mean diameter of droplets sizing has fallen, also by increasing this quantity from 30 to 40, and 50 respectively, this manner has continued. Also, by raise of the dump angle from 0° (across cylinder) to 30° the mean diameter of droplets sizing has increased gently, but with growth of this angle from 30° to 45° and 60°, the mean diameter of droplets sizing has risen sharply.

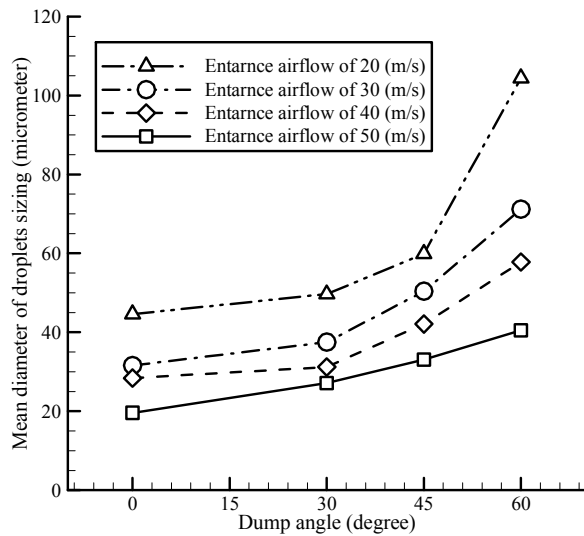

Fig. 4 The variation of mean diameter in different dump angle

V. CONCLUSION

B. Effective Mass Fraction

In accordance with tables 2 to 5, by raise of entrance airflow velocity the effective mass fraction has fallen and also with growth of dump angle from 0° to 60° the effective mass fraction has decreased rapidly, some comparative graphs has been shown in figures 5 to 6.

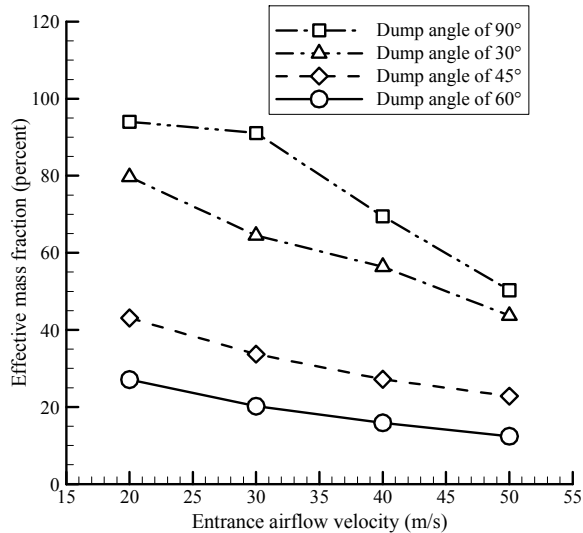

Fig. 5 The variation of effective mass fraction in different entrance airflow velocity

According to figures 5 and 6, with increase of entrance airflow velocity from 20 up to 50 (m/s), the effective mass fraction has dropped gradually. Also, by growth of dump angle from 0° to 30° , the effective mass fraction decreased correspondingly, but with rise of this parameter from 30° to 45° and 60° respectively, the effective mass fraction has fallen suddenly.

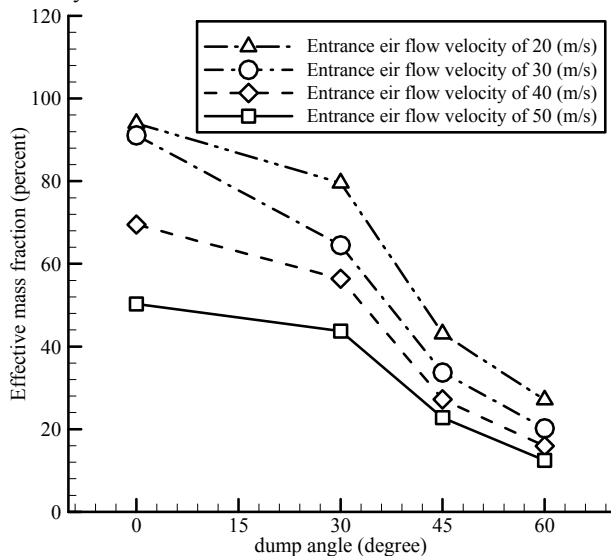

Fig. 6 The variation of effective mass fraction in different dump angle

The effects of side-dump angle and entrance airflow velocity on droplet sizing and effective mass fraction were studied by a numerical procedure. The results show, with growth of side-dump angle from 0° to 30° the mean diameter of fuel droplets sizing has increased gradually, but with growth of this quantity from 30° to 45° and 60° correspondingly, the mean diameter of droplets sizing has risen sharply. Also, by raising the entrance airflow velocity from 20 to 30, 40 and 50 (m/s) respectively, the mean diameter of droplets sizing has fallen dramatically.

The consequences illustrate, with increase of side-dump angle from 0° to 30° , the effective mass fraction has fallen gradually, but with increase of this amount from 30° to 45° and 60° correspondingly, the effective mass fraction has dropped rapidly. Also, effective mass fraction has an inverse relation with entrance airflow velocity. It means, by raising the entrance airflow velocity, the effective mass fraction has decreased.

REFERENCES

- [1] M. Mojtahedpoor, *Effects of Injection Velocity and Entrance Air Flow Velocity on Droplet Sizing in a Duct*, world academy of science, technology and engineering journal, March 2011.
- [2] M. M. Doustdar, M. Mojtahedpoor, *A Numerical Study on the Effects of Injection Spray Cone and Pressure on Propulsive Droplets in A Ramjet*, World Academy of Science, Engineering and Technology Journal, pp. 383-386, April 2011.
- [3] M. M. Doustdar, M. Mojtahedpoor, M. Wadizadeh, *Effects of Injection Initial Conditions and Length-To-Diameter Ratio on Fuel Propulsive Droplets Sizing in A Duct*, International Conference on Mechanical and Aerospace Engineering, New Delhi, India, March 2011.
- [4] M. M. Doustdar, M. Mojtahedpoor, *A Numerical Study on the Effects of Fuel Injection Angle and Injection Velocity on Propulsive Droplets Sizing in a Duct*, Singapore, 2011.
- [5] T. H. Ko, *A Numerical Study on the Effects of Side-Inlet Angle on the Mixing Phenomena in A Three-Dimensional Side-Dump Combustor*, International Communications In Heat And Mass Transfer, Vol 33, Issue 7, pp. 853-862, August 2006.
- [6] T.H. Ko, *Three-Dimensional Fuel-Air Mixing Phenomena in A Side-Dump Combustor: A Numerical Study*, International Communications in Heat And Mass Transfer, Vol 32, Issue 10, pp. 1360-1374, November 2005.
- [7] M. M. Doustdar, M. Mojtahedpoor, *A Numerical Study of the Effect of Injection Velocity on Fuel Droplets Sizing In A Three-Dimensional Side-Dump Combustor*, Applied Mechanics And Materials, Vol 52-54, pp. 2045-2050, March 2011.
- [8] A. Amsden, P. J. O'Rourke, T. D. Butler, *KIVA-II: A Computer Program for Chemically Reactive Flows with Sprays*, Los Alamos National Laboratory Report, LA-11560-MS, May 1989.

M. Mojtahedpoor is 26 from Iran. He received a B.Sc. in Mechanical Engineering from Islamic Azad University, Mashhad in 2008. He has worked in a research center. He received M.Sc degree from Imam Hossein University of Tehran. After this degree, he became one of the members of Young Research Club in Science and Research Branch, Islamic Azad University of Tehran. He is a PhD student now and he is interested in combustion, turbulence, CFD and numerical methods.