

A New Method of Adaptation in Integrated Learning Environment

Ildar Galeev, Renat Mustaphin, and Cemal Ardil

Abstract—A new method of adaptation in a partially integrated learning environment that includes electronic textbook (ET) and integrated tutoring system (ITS) is described. The algorithm of adaptation is described in detail. It includes: establishment of Interconnections of operations and concepts; estimate of the concept mastering level (for all concepts); estimate of student's non-mastering level on the current learning step of information on each page of ET; creation of a rank-order list of links to the e-manual pages containing information that require repeated work.

Keywords—Adaptation, Integrated Learning Environment, Integrated Tutoring System, Electronic Textbook.

I. INTRODUCTION

BY present time, a lot of methods and techniques of adaptive hypermedia have been described [1]. Adaptation in educational hypermedia is based on the level of the learner's knowledge. The knowledge state of particular learners, as a rule, changes in different ways during the teaching and learning process. To describe the learner's knowledge of the subject, an overlay model based on the subject domain model is most commonly used. The domain model is represented as a network of domain concepts. For every domain model concept the overlay model of each particular learner contains certain values, which are used to assess the level on which he knows this concept. Hence, the overlay model of the learner's knowledge is represented as a set of pairs "concept – value" for every domain concept and serves to implement adaptation technologies in educational hypermedia. Software tools of MONAP family are designed for elaboration of ITS where adaptation is based on the overlay model of the learner's skills. This model is represented by a number of pairs "operation (rule) - meaning" [2-6]. The overlay model of skills provides the basis for the adaptive control of the learner, consisting in giving him a tutorial problem of an optimal difficulty and complexity for the next training step.

II. OBJECTIVES

Integrated environment, including an electronic textbook (ET) and an intelligent tutoring system, gives additional possibilities in raising the level of the teaching/learning process adaptability.

Ildar Galeev, Renat Mustaphin are with the IT Department, Kazan State Technological University, K. Marx St., 68, Kazan 420015, Tatarstan, Russia.

Cemal Ardil is with the Azerbaijan National Academy of Aviation, Baku Azerbaijan (e-mail: cemalardil@gmail.com).

Such environments require the development of new integrated methods of adaptation to the learner, providing, in particular, presentation of relevant educational material according to the results of solving the tutorial problem.

III. METHODOLOGY

In accordance with the algorithmic approach of L. Landa [7], the main emphasis in the educational environment being described was placed on the adaptively supervised and controlled solution of tutorial problems. Since in the teaching/learning process a human (a learner) is an execution unit for the analyzed algorithms, the latter can differ essentially from the mathematical notion of the algorithm (Turing machine, normal algorithm, recursive function). Unlike classical algorithms (algorithms in a general mathematical sense), their operations being formal, the algorithms under consideration allow operations of a meaningful, subjective nature, i.e. depending on human understanding. Thus, the simplicity of operations performed by the learner in the problem solution process is relative and depends on a number of factors, including the degree of being trained. Another permitted difference is the weakening of the determinancy property. To designate algorithms with the abovementioned properties, L. Landa introduced the concept of algorithmic-type orders, or algorithmic orders [7].

The development of an algorithmic order is generally a weakly formalized, multi-criteria problem, solved by the expert-teacher. As a result of the subject domain analysis, basic (primary) elements are selected. These elements are simple notions (concepts), which serve as the foundation for building the educational material under consideration. Taking into account the chosen concepts and on the basis of the structural-algorithmic analysis of the activity in solving definite class problems, standard operations are singled out, which represent the content of the activity in question. The term "standard operation" is used in reference to any operation, conceptually complete, taking into account a specific character of the teaching/learning SD, presuming elementary manipulations with concepts. For example, in the ITS teaching grammar of the German language and designed with the aid of software tools of MONAP family, the concepts are: gender, number, case, etc., and one of the operations describing the adjective declension is represented as the rule: "IF the adjective and the noun are preceded by the definite article *der* or one of the pronouns *dieser, jener, solcher, jeder, welcher*, and the attributed noun is of masculine gender, THEN the adjective ending is – *e*" [2].

Thus, the following main steps of learning process can be defined:

- Study of the subject's theory
- Conceptual knowledge control of the subject under study
- Skill acquisition – controlled process of training task solution

For one learning subject, several e-textbooks and controlling tests corresponding to the knowledge level of the student can be evaluated or known methods of adaptive hypermedia can be realized [1]. Integration of these approaches with adaptive engines of ITS increases the possibilities of adaptive control of learning process in many times. A number of trajectories of knowledge and skills acquiring are shown at Fig. 1 [5].

Adaptive skills generation is made under control of ITS, created with the tools of MONAP family (Fig. 2) [2-6].

In the learning model (Fig. 2) that provides adaptive control of skills acquiring the following didactic principles invariant to the learning subject are realized:

- Training task properties definition and relevant theory delivery should be carried out on the basis of student's skills mastering estimate at every step of their acquisition
- During learning process, "from easy to difficult" approach should be observed
- Shift to new learning material should be made if the previous material was successfully mastered (condition of the shift from one subclass of tasks to another)
- During learning, a subjective degree of training task difficulty must be stabilized for each student

There is a number of close definitions of training task difficulty degree

- Training task difficulty assumes comparing learning material that needs to be mastered with cognitive abilities of student
- Speaking about information, training task difficulty coincides with subjective newness and information saturation of learning material for certain student

Formally, in the proposed model (Fig. 2) the measure of training task difficulty is the average fraction of mistakes, expected while solving the task [3]. The same training task is of different difficulty for different students.

Thus, difficulty as a concept is related directly not only to training task, but also to the process of its solving.

III. TECHNOLOGICAL DESCRIPTION

To solve a tutorial problem, a certain algorithmic order implementation is used, which is characterized by the applied set of operations y_j ($y_j \in Y$, $j = \overline{1, J}$) determining the problem properties. Thus, to identify a certain algorithmic order implementation unambiguously, it is necessary to utilize the identifier rq ($q=1, 2, \dots, Q_r$), where r identifies the class of implementations, and q – the implementation inside the class. Implementations Θ_{rq_1} and Θ_{rq_2} , falling into the same r -th

class, differ in that different vectors of the operations used L_{rq_1} and L_{rq_2} describe them, i.e.: $L_{rq_1} \neq L_{rq_2}$, where

$r \in [1, R]$; $q_1, q_2 \in [1, Q_r]$. The conducted classification of the algorithmic order implementations determines invariant to SD forms of representing operations (the basis RULES) and properties of tutorial problems (the basis PROPERTIES), designed and maintained by software tools of the MONAP family (Fig. 3). The record of the basis RULES consists of the following fields: type of the operation j ; text in the natural language of the j -type operation, included into the algorithmic order in the form: "IF (condition), THEN (action)". The record of the Basis PROPERTIES consists of the following fields: identifier of the tutorial problem rq type; vector of the operations $L_{rq} = [L_1, L_2, \dots, L_j, \dots, L_J]$, used for solving

problems of the mentioned type, where L_j is the number of j -type operations. The kernel of the overlay model of the learner's skills is represented as the vector $P(k) = [P_1(k), P_2(k), \dots, P_j(k), \dots, P_J(k)]$, where $P_j(k)$ is the probability of using the j -type operation correctly. This probability is calculated with the application of Bayesian approach and the results of solving the tutorial problem at the k -th step of training [3, 6].

The electronic textbook can be developed with the help of any tools available to the teacher. They range from text processors, like MS Word containing an option "Save as HTML", or editors, like MS FrontPage, Adobe Pagemill, to specialized tools (Fig. 3). The limitation is the access provision to the textbook by standard browsers (MS IE, NS Navigator). A great number of learning environments can be built in one and the same SD. They reflect both different ideas of different expert-teachers about the teaching/learning process, and different ideas of one expert-teacher about it for different groups of learners. This brings up a possibility of creating a set of learning environments in one SD. They possess a certain mechanism of inheriting properties, which ensures utilization of these or those specific knowledge components from one learning environment in another one (Fig. 3).

IV. RELEVANT LEARNING MATERIAL DEFINITION

Establishing interconnections between operations and concepts provides presentation of relevant educational material to the learner according to the results of solving the tutorial problem. Interconnection of operations (rules) and concepts is specified by the matrix $\|e_{jt}\|$, its lines corresponding to the operations $y_1, y_2, \dots, y_j, \dots, y_J$, and columns – to the concepts $x_1, x_2, \dots, x_t, \dots, x_T$. The element of the matrix $\|e_{jt}\|$ is determined in the following way:

$$e_{jt} = \begin{cases} 1, & \text{if concept } x_t \text{ is used in operation } y_j; \\ 0, & \text{in the opposite case.} \end{cases}$$

Table 1 shows the example of the matrix $\|e_{jt}\|$ with an additional lower line, containing elements $\alpha_t (t = \overline{1, T})$, where $\alpha_t = \sum_j e_{jt}$ is a number of operations from the whole multitude of operations Y , in which the concept x_t is used.

TABLE I
MATRIX OF INTERCONNECTION BETWEEN OPERATIONS AND CONCEPTS

OPERATIONS (RULES)	CONCEPTS					
	x_1	x_2	...	x_t	...	x_T
y_1	1	1	...	0		0
y_2	0	1	...	0		1
...
y_j	1	0		1		0
...
y_J	0	0		1		1
	α_1	α_2	...	α_t	...	α_T

Matrix $\|e_{jt}\|$ is a formalized description of the operation structures. To provide program implementation of the described adaptation method, a corresponding line of the matrix $\|e_{jt}\|$ enlarges every record of the RULE (Fig. 3). In accordance with the abovementioned algorithmic approach, the concept used in the operation is its part and parcel. Hence, at every k -th step of learning the level of the learner's mastering of every concept used in the operation y_j cannot be lower than the level of mastering this operation as the whole at the same step, i.e. $\omega_t(k) \geq P_j(k)$, where $\omega_t(k)$ is the evaluation of the level of mastering the concept x_t . In the general case it is impossible to calculate $\omega_t(k)$ more properly by the result of performing the operation y_j , because there is no adequate feedback. As a rule, a qualifying dialogue with the learner provides the necessary feedback. The dialogue is subject-dependent and, thus, cannot be used to develop methods of evaluating the learner's knowledge invariant to SD. In the context of the fact, that when the tutorial problem is being solved at the k -th step of learning, one and the same concept can be used in different operations, in order to calculate the integral estimate of the concept x_t mastering levels, it is necessary to take into consideration these operations mastering level. So, to calculate the integral estimate of the concept x_t mastering level $\omega_t(k)$ by the results of executing the tutorial task at the k -th training step, the following formula is proposed:

$$\omega_t(k) = \frac{\sum_j e_{jt} \cdot P_j(k)}{\alpha_t} \tag{1}$$

In a similar manner, the interconnection between ET pages and the concepts, described in these pages, specifies the interconnections between operations and concepts (Table I). This interconnection is specified by the matrix $\|f_{gt}\|$, its lines corresponding to pages $s_1, s_2, \dots, s_g, \dots, s_G$, and columns – to concepts $x_1, x_2, \dots, x_t, \dots, x_T$. The element of the matrix $\|f_{gt}\|$ is determined in the following way:

$$f_{gt} = \begin{cases} 1, & \text{if concept } x_t \text{ is described in page } s_g; \\ 0, & \text{in the opposite case.} \end{cases}$$

The estimate of the learner's non-mastering $\beta_g(k)$ the knowledge, given in the ET at page s_g , at the k -th training step is calculated according to the formula:

$$\beta_g(k) = \frac{\sum_t f_{gt} \cdot (1 - \omega_t(k))}{\sum_t f_{gt}} \tag{2}$$

Using $\omega_t(k)$ values calculated on the basis of $P_j(k)$ values, when calculating $\beta_g(k)$, makes it possible to take into account the prehistory of the tutorial task execution by the learner, this being an important requirement at building adaptive tutorial systems. When the task is finished but there are mistakes, a message is formed, containing a list of references to the ET pages (Fig. 3) and telling the learner to return to the work over the educational material given there. The list of ET pages is sorted according to $\beta_g(k)$ values decrease, i.e. the learner is offered to study first of all the pages, which were worse mastered. The implementation of the proposed method of determining relevant ET pages, corresponding to the learner's knowledge and skills at the k -th training step, required to widen the learning environment, created and maintained by software tools of MONAP family [2, 3]. To provide the link between the ET concepts and the ITS operations, a new parameter of the integrated learning environment – “the number of the concepts being studied” – has been introduced (Fig. 3).

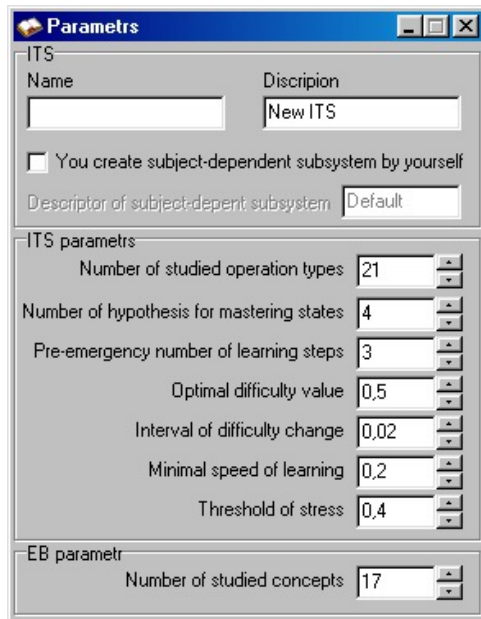

Fig. 4 Parameters of learning process model

Together with the modification of the basis RULE, the basis CONCEPTS, being a matrix $\|f_{gt}\|$ (Fig. 3), is developed and maintained. A properly organized thesaurus, included into the ET general information components, can fulfill the function of the matrix $\|f_{gt}\|$ as well. In this case it is not necessary to create the basis CONCEPTS.

V. FURTHER STEPS

Invariance of the described adaptation mechanisms to SD makes them potentially easily replicated. Software tools of the MONAP family have an open architecture that gives the possibility of their integration with other author's tools for creating and support of learning environments (virtual universities). In this connection, furthers steps include:

- searching for partners in order to develop integrated software tools containing patners' tools and MONAP (<http://ittal.kstu.ru>);
- choosing topical educational domains and designing adaptive integrated learning environments for them that contain electronic textbooks and intellectual tutoring systems.

V. CONCLUSION

The efficiency of the computer-assisted teaching and learning process is mostly determined by the progress, achieved when solving the following problems: development of multifunctional integrated learning environments and provision of adaptive learning in these environments. In line with the purpose in hand, a partially integrated learning environment has been developed. This environment includes ET and ITS. Adaptation to the learner is based on the skills overlay model, designed and maintained by software tools of the MONAP family.

A new, additional adaptation method, integrated into software tools, has been developed as well. Relevant for the learner educational material, represented in ET, is determined at every training step on the basis of the tutorial problem solution results.

REFERENCES

- [1] Brusilovsky, P. Methods And Techniques Of Adaptive Hypermedia. User Modeling and User-Adapted Interaction, 6 (2-3), 1996, pp. 87-129.
- [2] I. Galeev. Automation of the ETS Desing, Educational Technology - September-October 1999. - V. XXXIX, No. 5. - pp. 11-15.
- [3] Galeev I., Chepegin V. and Sosnovsky S., MONAP: Models, Methods and Applications, Proceedings of the International Conference KBCS 2000, Mumbai, India. pp. 217-228.
- [4] Ildar Galeev, Larissa Tararina and Oleg Kolosov, "Problems of building adaptive integrated learning environments", in Vladan Devedzic, J. Michael Spector, Demetrios G. Sampson and Kinshuk (ed): Proceedings of 3rd IEEE International Conference on Advanced Learning Technologies (ICALT'2003), Athens, Greece, July 9-11, 2003, p. 486.
- [5] Ildar Galeev, Larissa Tararina, Oleg Kolosov, Vlad Kolosov, Structure and implementation of partially integrated adaptive learning environment, in Allison Rossett (ed): Proceedings of E-Learn 2003, Phoenix, Arizona USA, November 7-11, 2003, p. 2151-2154.
- [6] Ildar Galeev, Larissa Tararina and Oleg Kolosov, "Development of software tools for intelligent tutoring systems", in Lora Aroyo and Carlo Tasso (ed): Workshop Proceedings (Part I) of 3rd International Conference on Adaptive Hypermedia and Adaptive Web-Based Systems (AH'2004), Eindhoven, The Netherlands, 23rd August 2004, p. 14-19.
- [7] Landa, L. Algorithmization in Learning and Instruction. Englewood Cliffs, NJ: Education Technology Publications, 1974.

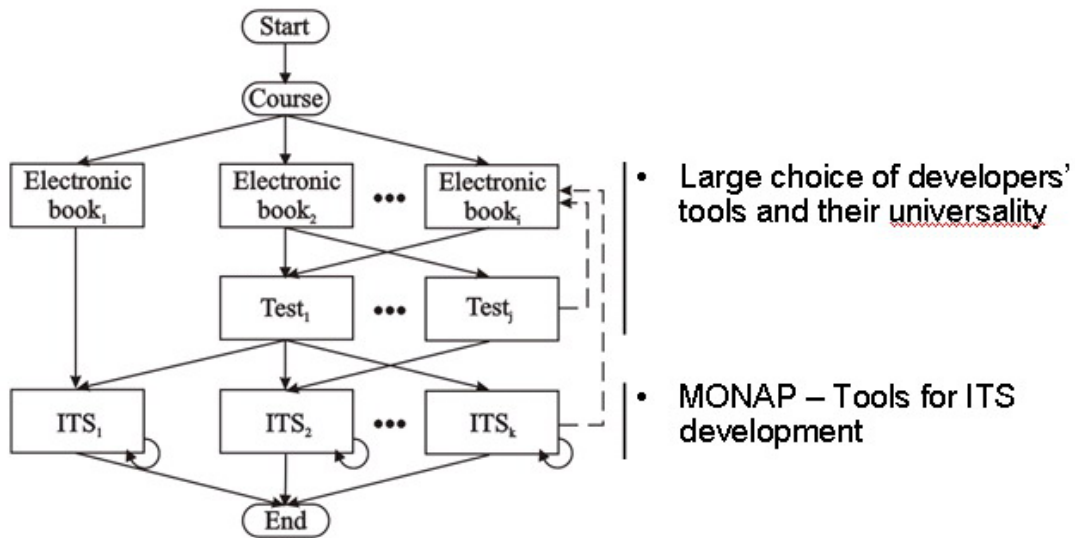

Fig. 1 A number of trajectories of knowledge and skills acquiring

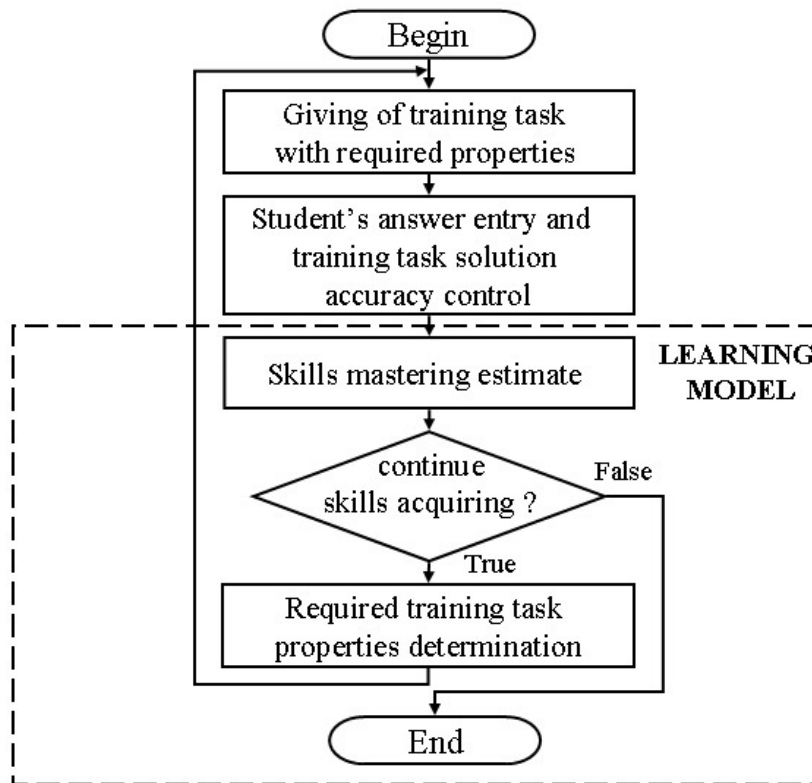

Fig. 2 Skills acquiring management

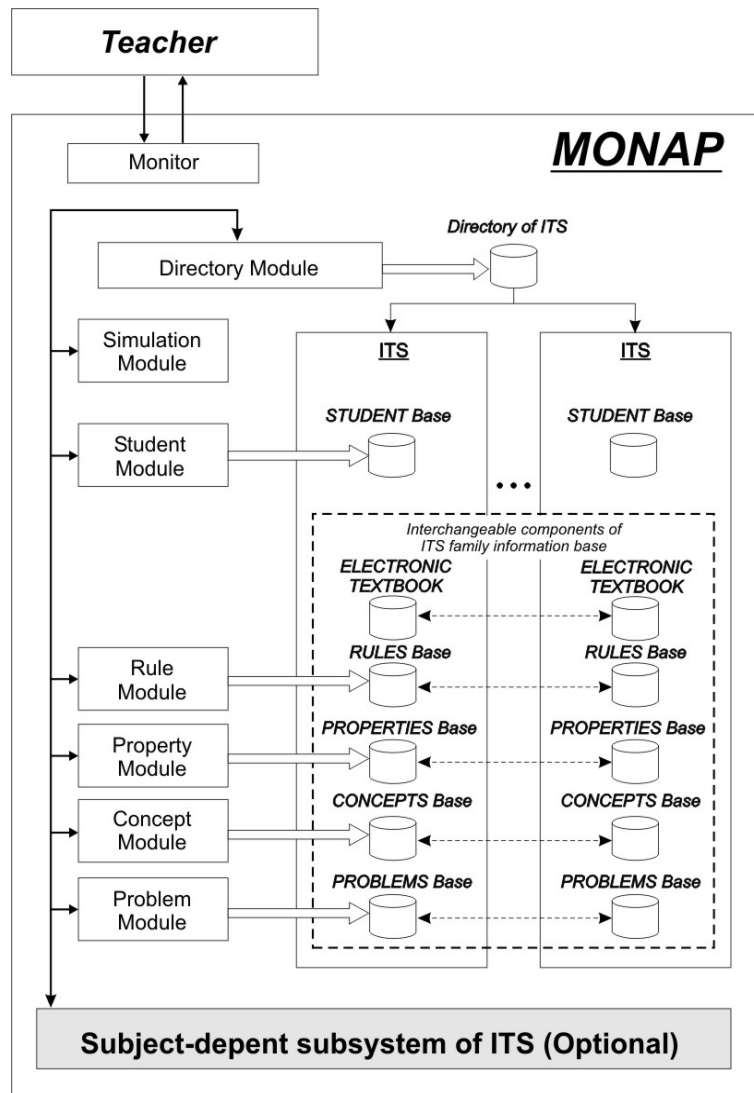

Fig. 3 The structure of the information basis