

# A Literature Survey of Neural Network Applications for Shunt Active Power Filters

S. Janpong, K-L. Areerak\* and K-N. Areerak

**Abstract**—This paper aims to present the reviews of the application of neural network in shunt active power filter (SAPF). From the review, three out of four components of SAPF structure, which are harmonic detection component, compensating current control, and DC bus voltage control, have been adopted some of neural network architecture as part of its component or even substitution. The objectives of most papers in using neural network in SAPF are to increase the efficiency, stability, accuracy, robustness, tracking ability of the systems of each component. Moreover, minimizing unneeded signal due to the distortion is the ultimate goal in applying neural network to the SAPF. The most famous architecture of neural network in SAPF applications are ADALINE and Backpropagation (BP).

**Keywords**—Active power filter, neural network, harmonic distortion, harmonic detection and compensation, non-linear load.

## I. INTRODUCTION

IN recent decades, there are many studies about harmonic distortion with techniques to improve power quality. The harmonic is defined in many literatures as “a component of a periodic wave having a frequency that is an integral multiple of the fundamental power line frequency” [1]. The meaning of the harmonic can be easily explained using the following example. Let “f” represents a fundamental frequency, the 2<sup>nd</sup> harmonic has frequency 2f Hz, the 3<sup>rd</sup> harmonic has frequency 3f Hz, and so on [2]. The 2<sup>nd</sup>, 4<sup>th</sup>, 6<sup>th</sup>, etc., are called even harmonics while the 3<sup>rd</sup>, 5<sup>th</sup>, 7<sup>th</sup>, etc., are called odd harmonics [2]. Harmonic distortion occurs when non-linear loads, such as rectifier, inverters, adapters, etc., are feeded from power systems [3], [4], [5] and changes a sinusoidal wave at a fundamental frequency to different non-sinusoidal waves as shown in Fig. 1. The negative effects of harmonic distortion can be listed as follows [6], [7].

- 1) Premature aging or damaging of the electrical device or consumer equipment.
- 2) Interfering with power system protection, such as, circuit breaker or blown fuses.
- 3) Interfering the electronics communication

Sarawat Janpong is a Ph.D. student in School of Electrical Engineering, Suranaree University of Technology, Nakhon Ratchasima, 30000, THAILAND. (e-mail: 5440177@g.sut.ac.th).

\*K-L. Areerak, Assistant Professor, PQRU Research unit, PeMC research group, School of Electrical Engineering, Suranaree University of Technology Nakhon Ratchasima, 30000, THAILAND (corresponding author: kongpol@sut.ac.th).

K-N. Areerak, lecturer, PeMC research group, School of Electrical Engineering, Suranaree University of Technology Nakhon Ratchasima, 30000, THAILAND.

- 4) Miss leading to erroneous operation of control system components

Because of the reasons mentioned above, therefore, an operation to eliminate the harmonic components is required to achieve the total harmonic distortion (THD) following on the international standards IEC and IEEE.

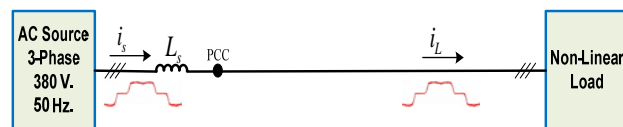

Fig. 1 Non-linear load in the electrical power system

At present, there are three common techniques for harmonic reduction/elimination, which are passive power filter (PPF), active power filter (APF), and hybrid power filter (HPF). PPF is a simple and robust technique with low cost. However, it is sensitive to the environments and easy to overload. APF can be divided into AC and DC filters which is mainly used as a current or voltage harmonic compensation [8]. There are three classification of APF – converter-based classification, topology-based classification, and supply-system-based classification. HPF is a combination of various types of PPF and APF [9].

The aim of this paper is to present a survey of harmonic cancellation using shunt APF with an application of neural network (NN). Next section presents a foundation of Shunt APF and its operations. Section III describes the basic concept of neural network. Section IV presents a review of an application of NN in the APF from the IEEE database from 2006 – 2011. Finally, Section V is the conclusion and recommendation for the future research.

## II. SHUNT ACTIVE POWER FILTER

Shunt active power filter (SAPF) is commonly used as an effective method in compensating harmonic components in non-linear loads. Fig. 2 shows the basic principle of SAPF in which APF is connected in parallel to the power system at a point of common coupling (PCC) between metropolitan electricity authority (MEA) and power users. The objective of SAPF is to minimize the distortion in power supply using four main components – harmonic detection, compensating current control, DC bus voltage control, and active power filter – as shown in Fig. 3.

In the harmonic detection component, the distorted signal can be detected by several harmonic detection techniques, i.e.,

the instantaneous reactive power theory (PQ) [10], the synchronous reference frame (SRF) [11] – [13], the d-q axis with Fourier (DQF) [14], and the synchronous detection (SD) [15] – [16] etc. Then, APF injects the compensating currents into the power system [17]. The current control techniques are hysteresis current control [18] – [19], Pulse Width Modulation (PWM) [20] – [22], and Space Vector Modulation (SVM) [23] – [24] etc. For dc bus voltage control, proportional integral (PI) is employed [25]. Commonly, APF uses 6 IGBT devices to build the voltage source inverter for injecting the compensation current to the system at PCC. The architecture of APF with IGBT device is shown in Fig. 4.

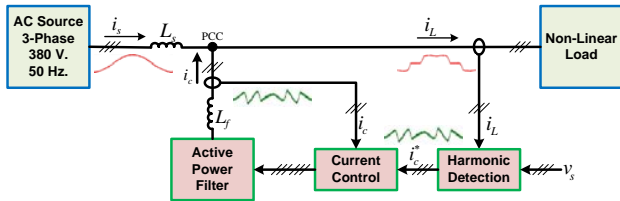

Fig. 2 The system using shunt active power filter

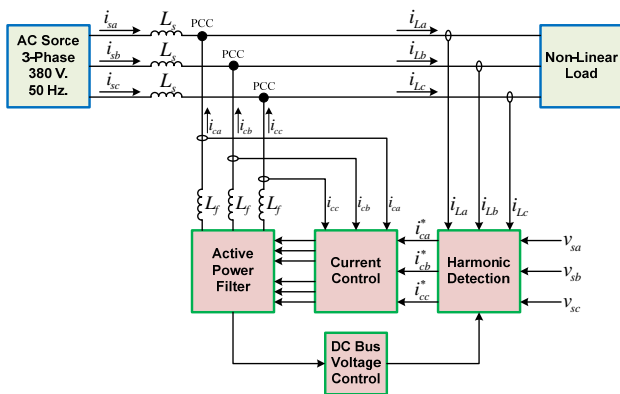

Fig. 3 Three – phase shunt active power filter

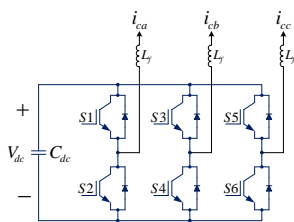

Fig. 4 IGBT bridge inverter in APF

III. CONCEPTS OF NEURAL NETWORK

Neural Network (NN) is the network that has structure and processes like human brain [26]. NN has been adopted to many applications to perform several tasks, e.g., fitting function, pattern recognition, clustering data, etc. Examples of the neural network application are aerospace, automotive, banking, defense, electronics, entertainment, financial,

industrial, insurance, manufacturing, medical, oil and gas, robotics, speech, securities, telecommunications, transportation, and so on [27]. The parallel processing with nonlinearity and adaptability property is described in many papers as the strength of NN.

NN architecture consists of three layers – input, hidden, and output layers. In the simplest form of neural network, there is only input and output layer which is directly connected to each other. Like other networks, neural network can be designed or adapted to fit the characteristics of each problem. The following is the suggestion of the designing steps when neural network is chosen to solve any problems.

1. Weight initialization
2. Number of hidden layers
3. Number of neurons in each hidden layer
4. Number of input variables or combination of input variables
5. Learning rate
6. Momentum rate
7. Training cycle
8. Type of activation function
9. Data partitioning and evaluation metrics.

Perceptron, ADALINE or Widrow – Hoff, Backpropagation (BP), Radial Basis Function (RBF), Hopfield, Hebbian, Competitive, and Grossberg are examples of neural network architecture which have been designed for solving different characteristics of problems.

IV. AN APPLICATION OF NEURAL NETWORK IN APF

As mentioned in section III, there are many conventional techniques to detect and compensate harmonic current. This article presents a general outline for the research literature on how to solve harmonic distortion problem by artificial neural network (ANN). ANN is one of the modern techniques which is used in many areas of application including harmonic eliminations. Fig. 5 shows an architecture of three-phase diagram of neural network controlled SAPF. A NN is used to control the compensating current injection with SAPF [28].

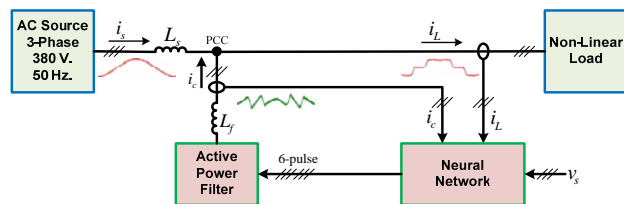

Fig. 5 The active power filter control using NN approaches

Total of 50 papers from IEEE/IET Electronic Library (IEL) from 2006 – 2011 are reviewed. Several facts have been discovered and will be discussed later. Fig. 6 gives a review on which components of SAPF is substituted by neural network in each paper.

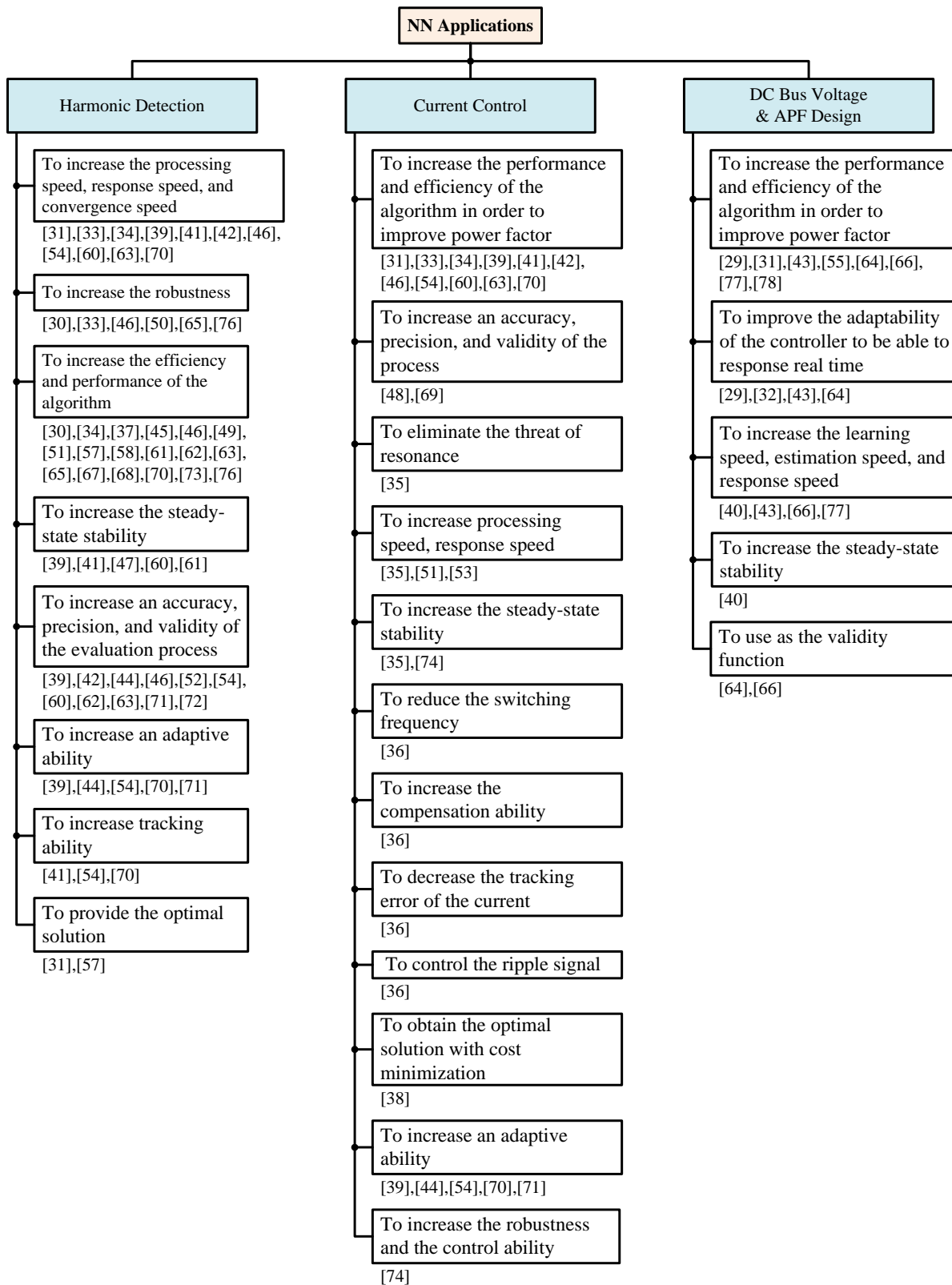

Fig. 6 Review of NN applications for SAPF

From the review, it shows that neural network is employed to substitute a harmonic detection component for the following reasons:

- 1) To increase the processing speed, response speed, and convergence speed [31], [33], [34], [39], [41], [42], [46], [54], [60], [63], [70].
- 2) To increase the robustness [30], [33], [46], [50], [65], [72].
- 3) To increase the efficiency and performance of the algorithm [30], [34], [37], [45], [46], [49], [51], [57], [58], [61], [62], [63], [65], [67], [68], [70], [73], [76].
- 4) To increase the steady-state stability [39], [41], [47], [60], [61].
- 5) To increase an accuracy, precision, and validity of the evaluation process [39], [42], [44], [46], [52], [54], [60], [62], [63], [71], [72].
- 6) To increase an adaptive ability [39], [44], [54], [70], [71], so that it can response in real time.
- 7) To increase tracking ability [41], [54], [70].
- 8) To provide the optimal solution [31], [57].

NN is easy and convenient to use [59] as a substitution of the current control component. Furthermore, the following reasons are also given as the merit of the NN for current control process.

- 1) To increase the performance and efficiency of the algorithm in order to improve power factor [38], [48], [56], [59], [74], [75].
- 2) To increase an accuracy, precision, and validity of the process [48], [69].
- 3) To eliminate the threat of resonance [35].
- 4) To increase processing speed, response speed [35], [51], [53].
- 5) To increase the steady-state stability [35], [74].
- 6) To reduce the switching frequency [36].
- 7) To increase the compensation ability [36].
- 8) To decrease the tracking error of the current [36].
- 9) To control the ripple signal [36].
- 11) To obtain the optimal solution with cost minimization [38].
- 12) To increase an adaptive ability [39], [44], [54], [70], [71], so that it can response in real time.
- 13) To increase the robustness and the control ability [74].

For the DC-Bus Voltage Control and SAPF Design, NN has been adopted for many reasons as follows:

- 1) To increase the performance and efficiency of the algorithm in order to improve power factor [29], [31], [43], [55], [64], [66], [77], [78].
- 2) To improve the adaptability of the controller to be able to response real time [29], [32], [43], [64].
- 3) To increase the learning speed, estimation speed, and response speed [40], [43], [66], [77].
- 4) To increase the steady-state stability [40].
- 5) To use as the validity function [64], [66].

Table I presents the review of the neural network architecture which has been chosen to use as a part of SAPF components. The results reveal that ADALINE and Backpropagation algorithm are the most popular architectures

TABLE I  
NEURAL NETWORK TECHNIQUES FOR SAPF

Authors	ADALINE/ Widrow- Hoff	BP	Perceptron	RBF	Hopfield
[29]	/				
[30]				/	
[31]	/				
[32]		/			
[33]	/				
[34]	/				
[35]				/	
[36]		/			
[37]			/		
[38]					
[39]		/			
[40]		/			
[41]	/				
[42]				/	
[43]	/				
[44]		/			
[45]	/				
[46]	/	/			
[47]	/				
[48]	/				
[49]	/				
[50]	/				
[51]	/				
[52]		/			
[53]		/			
[54]		/			
[55]	/	/			
[56]	/	/			
[57]		/			
[58]	/				
[59]		/			
[60]	/				
[61]	/				
[62]	/				
[63]	/				
[64]	/				
[65]		/			
[66]	/				
[67]	/				
[68]	/				
[69]		/			
[70]					/
[71]		/			
[72]		/			
[73]	/	/			
[74]		/			
[75]		/			
[76]	/				
[77]		/			
[78]		/			

that have been applied to SAPF, because both architectures are highly efficient learning than other architectures for SAPF.

Table II present some detail for NN architecture that use with SAPF.

[5] C.Y. Hsu and H.Y. Wu, "A new single-phase active power filter with reduced energy storage", in *Proc. IEE International Conference on Electronic Power Application*, vol.143, no.1, pp.25-30, January 1996.  
 [6] EGS Electrical Group, *Power Quality Guidebook*. Rosemont, IL.

TABLE II  
NEURAL NETWORK ARCHITECTURE

NN ARCHITECTURE	STRUCTURE	LEARNING	TRANSFER FUNCTION
ADALINE/ Widrow-Hoff		Widrow-Hoff weight&bias learning rule	Linear
BP		-Gradient descent weight/bias -Gradient descent with momentum weight/bias	-Log-Sigmoid -Linear -Hyperbolic tangent sigmoid
Perceptron		-Perceptron weight&bias -Normalized perceptron weight&bias	-Hard-limit -Symmetric hard-limit
RBF		Spread parameter	-Radbas -Linear

V.CONCLUSION

From the reviews described in the paper, it reveals that neural network has been applied to several components of SAPF for several purposes, such as increase the processing speed, resist the changed of temperature, maintain the system stability and precision, and so on. Neural network has been claimed in several papers that it is a dual – algorithm – oriented learning, which enhances the simple architecture to the system. Moreover, there are lots of tool and technology which support large number of neural network applications. Therefore, neural network is very popular to all applications. In the future work, the artificial intelligence (AI) techniques will be applied to design the NN controller for shunt active power filter.

ACKNOWLEDGMENT

This work was supported by Suranaree University of Technology (SUT) and by the office of the Higher Education Commission under NRU project of Thailand.

REFERENCES

[1] C. Nalini Kiran, Subhransu Sekhar Dash, and S. Prema Latha, "A Few Aspects of Power Quality Improvement Using Shunt Active Power Filter," *International Journal of Scientific & Engineering Research*, vol.2, Issue 5, May 2011.  
 [2] Sandeep V. Rode and Siddharth A. Ladhake, "A Review on Technique for Reduction of Harmonic Distortion," *International Journal of Electrical and Power Engineering*, vol.5(1), pp. 62-64, 2011.  
 [3] Sasan Zabihi and Firuz Zare, "Active Power Filters with Unipolar Pulse Width Modulation to Reduce Switching Losses," in *Proc. 2006 International Conference on Power System Technology*, Chongqing, China, 2006.  
 [4] H. Jou, J. Wu, and H. Chu, "New single-phase active power filter", in *Proc. IEE Proceeding Electric Power Application*, vol. 141, no. 3, pp. 129-134, May 1994.

[7] Hsiung Cheng Lin, "Fast Power System Harmonic Detection using Intelligent Neural", in *Proc. IEEE ICSS2005 International Conference On Systems & Signals*, Kaohsiung, Taiwan, 2005.  
 [8] K.H. Yiauw and M.S. Khanniche, "A Novel Three-Phase Active Power Filter", *Power Engineering*, 2001, pp. 77-84.  
 [9] S.P. Litran, P. Salmeron, R.S. Herrera, and J.R. Vazquez, "New control strategy to improve power quality using a hybrid power filter", in *Proc. International Conference on Renewable Energies and Power Quality*, Santander, 2008.  
 [10] Shihong Wu, Junnan Wang, Rui Huang, and Dan Guo, "Harmonic Current Detection and Simulation with Active Power Filter Based on Simulink", in *Proc. International Conference on Intelligent Computation Technology and Automation (ICICTA)*, Guangdong, China, 2011.  
 [11] Mahmoud F. Shousha, Sherif A. Zaid, and Osama A. Mahgoub, "A Comparative Study on Four Time-Domain Harmonic Detection Methods for Active Power Filters Serving in Distorted Supply", in *Proc. International MultiConference of Engineers and Computer Scientists*, Vol.II. Hong Kong, March 16 – 18, 2011.  
 [12] K-L. Areerak and K-N. Areerak, "The Comparison Study of Harmonic Detection Methods for Shunt Active Power Filters", *World Academy of Science, Engineering and Technology*, Vol.70, 2010, pp.243-248.  
 [13] P. Santiprapan and K-L. Areerak, "Performance Improvement of Harmonic Detection using Synchronous Reference Frame Method", in *Proc. 4<sup>th</sup> International Conference on Circuits, Systems and Signals (GSS'10)*, Corfu Island, Greece, July 22-25, 2010.  
 [14] S. Sujitjorn, K-L. Areerak, and T. Kulworawanichpong, "The DQ Axis with Fourier (DQF) Method for Harmonic Identification", *IEEE Transactions on Power Delivery*, Issue 1, Jan 2007.  
 [15] C.L. Chen, C.E. Lin, and C. L. Huang, "Reactive and Harmonic Current Compensation for Unbalanced Three-phase Systems using the Synchronous Detection Method", *Electric Power Systems Research*, Vol. 26, Issue 3, April 1993, pp. 163-170.  
 [16] Bhuvaneswari, G., Nair, M.G., and KumarReddy, S., "Comparison of Synchronous Detection and I.Cosφ Shunt Active Filtering Algorithms", in *Proc. International Conference on Power Electronics, Drives and Energy Systems*, New Delhi, 2006.  
 [17] Tri Desmana Rachmildha, "Optimized Combined System of Shunt Active Power Filters and Capacitor Banks", *International Journal on Electrical Engineering and Informatics*, Vol. 3, Number 3, 2011.  
 [18] Karuppanan P. Saswat Kumar Ram, and KamalaKanta Mahapatra, "Three Level Hysteresis Current Controller Based Active Power Filter for Harmonic Compensation" in *Proc. International Conference on*

- Emerging Trends in Electrical and Computer Technology*, Tamilnadu, 2011.
- [19] Tarek A. Kasmieh and Hassan S. Omran, "Active Power Filter dimensioning Using a Hysteresis Current Controller", in Proc. World Academy of Science, Engineering and Technology, 2009.
- [20] Simone Buso, Luigi Malesani, Paolo Mattavelli, "Comparison of Current Control Techniques for Active Filter Applications", IEEE TRANSACTIONS ON INDUSTRIAL ELECTRONICS, VOL.45, NO.5, OCTOBER 1998, pp.722-729.
- [21] Rahmani, S, Al-Haddad, K., and Kanaan, H.Y., "Two PWM techniques for single-phase shunt active power filters employing a direct current control strategy", Power Electronics, Vol.1, Issue 3, pp.376-385, 2008.
- [22] J. Chelladurai, G. Saravana Ilango, C. Nagamani, and S. Senthil Kumar, "Investigation of Various PWM Techniques for Shunt Active Filter", in Proc. World Academy of Science, Engineering and Technology 39, 2008.
- [23] A. M. Massoud, S. J. Finney, and B. W. Williams, "Predictive Current Control of a Shunt Active Power Filter", in Proc. 35th Annual IEEE Power Electronics Specialists Conference, 2004.
- [24] N. Ghiasnezhad, M. Tavakoli Bina, and M. A. Golkar, "Two Efficient 3D-SVM Algorithms for Four-Wire Converters", European Journal of Scientific Research, Vol.27 No.1, pp.104-111, 2009
- [25] Hong Qiu, Yin Zhongdong, Liu Qiao, and Shan Renzhong, "A Direct Current Control of Shunt Active Power Filter", in Proc. International Conference on Energy and Environment Technology, Vol.2, Washington, 2009.
- [26] Indranarain Ramlall, "Artificial Intelligence: Neural Networks Simplified", International Research Journal of Finance and Economics, Vol.39, 2010, pp. 105 – 120.
- [27] Howard Demuth, Mark Beale, Martin Hagan, "Neural Network Toolbox™ 6 User's Guide", The MathWorks, Inc., 1992-2010, pp.1-4 to 1-6
- [28] J.L. Floresf Grarrido and P. Salmenron Revuelta, "Control of an active power filter using dynamic neural networks", in Proc. International Conference on Renewable Energies and Power Quality, Palma de Mallorca, 2006.
- [29] Avik Bhattacharya, Chandan Chakraborty, "A Shunt Active Power Filter With Enhanced Performance Using ANN-Based Predictive and Adaptive Controllers", IEEE Transactions on Industrial Electronics, Vol.58, No.2, February 2011, pp.421-428.
- [30] Eyad Almaita, Johnson A. Asumadu, "Harmonic Content Extraction in Converter Waveforms Using Radial Basis Function Neural Networks (RBFNN) and p-q Power Theory", Power and Energy Conference at Illinois (PECI), 2011 IEEE, 25-26 Feb. 2011, pp.1-7.
- [31] B.Vasumathi, S.Moorthi, "Harmonic Estimation Using Modified ADALINE Algorithm with Time-Variant Widrow – Hoff (TVWH) Learning Rule", Computers & Informatics (ISCI), 2011 IEEE Symposium, 2011, pp.113-118.
- [32] Ngac Ky Nguyen, Patrice Wira, Damien Flieller, Djaffar Ould Abdeslam, Jean Merckl'e, "A Comparative Experimental Study of Neural and Conventional Controllers for an Active Power Filter", IECON 2010 - 36th Annual Conference on IEEE Industrial Electronics Society, pp.1995-2000.
- [33] Gupta, S. P. Dubey, S. P. Singh, "Neural Network Based Active Power Filter for Power Quality Improvement", Power and Energy Society General Meeting, 2010 IEEE, pp.1-8.
- [34] Neeraj Sharma, Rakesh Gupta, Dulara Sharma, Anil Swarnkar, Nikhil Gupta, "Estimation and Elimination of Harmonics in Power System using Modified FFT with Variable Learning of ADALINE", Electric Power Quality and Supply Reliability Conference (PQ), 2010, pp.79 - 86.
- [35] S. Masjedi, M. Ahmadi, E. Pashajavid, "Improved Shunt APF Based On Using Adaptive RBF Neural Network and Modified Hysteresis Current Control", SPEEDAM 2010 International Symposium on Power Electronics Electrical Drives Automation and Motion, pp.216-220.
- [36] Wang Dazhi, Ji Guoqing, Li Jun, Sun Hualong, Liu Shengli, Song Keling, "A Novel Hysteresis Current Control Strategy Based on Neural Network", International Conference on Computer Design and Applications (ICCD), 2010, pp.V2-369 - V2-372.
- [37] C. F. Nascimento, A. A. Oliveira Jr, A. Goedel, I. N. Silva, P. J. A. Semi, "Neural Network-Based Approach for Identification of the Harmonic Content of a Nonlinear Load in a Single-Phase System", IEEE Latin America Transactions, Vol.8, No.1, March 2010, pp.65-73.
- [38] JIANG You-hua, CHEN Yong-wei, "Neural Network Control Techniques of Hybrid Active Power Filter", AICI '09, International Conference on Artificial Intelligence and Computational Intelligence, 2009, Vol.4, pp.26-30.
- [39] Chen Ying, Lin Qingsheng, "New Research on Harmonic Detection Based on Neural Network for Power System", IITA 2009, Third International Symposium on Intelligent Information Technology Application, 2009, Vol.2, pp.113-116.
- [40] Wang-chonglin, Ma-caoyuan, Li-dechen, Li-xiaobo, Wang-zhi, Tang-jiejie, "Study on Improved Neural Network PID Control of APF DC Voltage", Innovation Management and Industrial Engineering, 2009 International Conference on Information Management, Vol.1, pp.179-182.
- [41] Xinrong Mao, "The Harmonic Currents Detecting Algorithm Based on Adaptive Neural Network", IITA 2009. Third International Symposium on Intelligent Information Technology Application, 2009, Vol.3, pp.51-53.
- [42] Fu Guangjie, Zhao Hailong, "The study of the electric power harmonics detecting method based on the immune RBF neural network", ICICTA '09. Second International Conference on Intelligent Computation Technology and Automation, 2009, Vol.1, pp.121-124.
- [43] Serge Raoul, Dzondé Naoussi, Hervé Berviller, Jean Philippe Blondé, Charles Hubert Kom, Martin Kom, Francis Braun, "FPGA Implementation of Harmonic Detection methods using Neural Network", EPE '09, 13th European Conference on Power Electronics and Applications, 2009, pp.1-10.
- [44] Jing Yang, Guang Yang, Jing-Hua Gao, "A Power Harmonic Detection Method Based On Wavelet Neural Network", International Conference on Machine Learning and Cybernetics, Baoding, 12-15 July 2009, Vol.6.
- [45] Khalil Rahimi, Majid Pakdel, Mohammad Reza Yousefi, "Neural Adaptive Control of a Shunt APF and its realization of Analog circuit", EUROCON '09, IEEE EUROCON 2009, pp.272-277.
- [46] Avik Bhattacharya, Chandan Chakraborty, "Harmonic Elimination and Reactive Power Compensation through a Shunt Active Power Filter by Twin Neural Networks with Predictive and Adaptive Properties", ICIT 2009, IEEE International Conference on Industrial Technology, 2009, pp.1-6.
- [47] Maurizio Cirrincione, Marcello Pucci, Gianpaolo Vitale, Abdellatif Miraoui, "Current Harmonic Compensation by a Single-Phase Shunt Active Power Filter Controlled by Adaptive Neural Filtering", IEEE Transactions on Industrial Electronics, Vol.56 , Issue.8, August 2009, pp.3128-3143.
- [48] Mohd Amran, Mohd Radzi, Nasrudin Abd. Rahim, "Neural Network and Bandless Hysteresis Approach to Control Switched Capacitor Active Power Filter for Reduction of Harmonics", IEEE Transactions on Industrial Electronics, Vol.56, Issue.5, May 2009, pp.1477-1484.
- [49] Avik Bhattacharya, Chandan Chakraborty, "Predictive and Adaptive ANN (Adaline) Based Harmonic Compensation for Shunt Active Power Filter", ICIS 2008, IEEE Region 10 and the Third international Conference on Industrial and Information Systems, 2008, pp.1-6.
- [50] Madjid Boudjedaimi, Patrice Wira, Djaffar Ould Abdeslam, Said Djenoune, Jean-Philippe Urban, "Voltage Source Inverter Control with Adaline Approach for the Compensation of Harmonic Currents in Electrical Power Systems", IECON 2008, 34th Annual Conference of IEEE Industrial Electronics, 2008.
- [51] Ngac Ky Nguyen, Djaffar Ould Abdeslam, Patrice Wira, Damien Flieller, Jean Merckl'e, "Artificial Neural Networks for Harmonic Currents Identification in Active Power Filtering Schemes", IECON 2008, 34th Annual Conference of IEEE Industrial Electronics, 2008.
- [52] Claudionor F. Nascimento, Azauri A. Oliveira Jr, Alessandro Goedel, Ivan N. Silva, Marcelo Suetake, "A Neural Networks-Based Method for Single-Phase Harmonic Content Identification", IECON 2008, 34th Annual Conference of IEEE Industrial Electronics, 2008.
- [53] Sindhu M. R., Manjula G. Nair, T. N. P. Nambiar, "An ANN based Digital Controller for a Three-phase Active Power Filter", POWERCON 2008, Joint International Conference on Power System Technology and IEEE Power India Conference, 2008, pp.1-7.
- [54] Dai Wenjin, Xie Youhui, Dai Yongtao, "A Neural Network Adaptive Detecting Approach of Harmonic Current", ISISE '08, International Symposium on Information Science and Engineering, 2008, Vol.1, pp.307-311.
- [55] Djaffar Ould Abdeslam, Patrice Wira, Jean Merckl'e, Damien Flieller, "Artificial Neural Networks to Control an Inverter in a Harmonic Distortion Compensation Scheme", ISIE 2008, IEEE International Symposium on Industrial Electronics, 2008, pp.1879-1884.
- [56] Wenjin Dai, Yu Wang, "Active Power Filter of Three-phase Based on Neural Network", ICNC '08, Fourth International Conference on Natural Computation, 2008, Vol.7, pp.124-128.

- [57] Guiying Liu, Shiping Su, Peng Peng, "Intelligent Control and Application of All-function Active Power Filter", 2008 International Conference on Intelligent Computation Technology and Automation (ICICTA), Vol.1, pp.1078-1081.
- [58] P. Wira, D. Ould Abdeslam, J. Mercklé, "Learning and adaptive techniques for harmonics compensation in power supply networks", MELECON 2008, The 14th IEEE Mediterranean Electrotechnical Conference, 2008, pp.719-725.
- [59] Yongtao.Dai, Wenjin.Dai, "Harmonic and Reactive Power Compensation with Artificial Neural Network Technology", WCICA 2008, 7th World Congress on Intelligent Control and Automation, 2008 June 25-27, Chongqing, China, pp.9001-9006.
- [60] He Na, Huang Lina, Wu Jian, Xu Dianguo, "An Artificial Neural Network Based Method for Harmonic Detection in power system", APEC 2008, Twenty-Third Annual IEEE Applied Power Electronics Conference and Exposition, 2008, pp.456-461.
- [61] Maurizio Cirrincione, Marcello Pucci, Gianpaolo Vitale, "A Single-Phase DG Generation Unit With Shunt Active Power Filter Capability by Adaptive Neural Filtering", IEEE Transactions on Industrial Electronics, Vol.55, No.5, May 2008, pp.2093-2110.
- [62] M. Mohseni, M. A. Zamani, M. Joorabian, "Harmonic Components Identification through the Adaline with Fuzzy Learning Parameter", IECON 2007, 33rd Annual Conference of the IEEE Industrial Electronics Society, Nov. 5-8, 2007, Taipei, Taiwan, pp.2515-2520.
- [63] Boguslaw Swiatek, Marek Rogoz, Zbigniew Hanzelka, "Power System Harmonic Estimation Using Neural Networks", EPQU 2007, 9th International Conference on Electrical Power Quality and Utilisation, Barcelona, 9-11 October 2007, pp.1-8.
- [64] Wenjin Dai, Taiyang Huang, Na Lin, "Single-phase Shunt Hybrid Active Power Filter Based on ANN", FSKD 2007, Fourth International Conference on Fuzzy Systems and Knowledge Discovery, 2007, Vol.2, pp.40-44.
- [65] Claudionor F. Nascimento, Azauri A. Oliveira Jr., Ivan N. Silva, Jose R. B. A. Monteiro, "Harmonic Detection Based on Artificial Neural Networks for Current Distortion Compensation", ISIE 2007, IEEE International Symposium on Industrial Electronics, 2007, pp.2864-2869.
- [66] Dai Wenjin, Huang Taiyang, "Design of Single-phase Shunt Active Power Filter Based on ANN", ISIE 2007, IEEE International Symposium on Industrial Electronics, 2007, pp.770-774.
- [67] Djaffar Ould Abdeslam, Patrice Wira, Jean Mercklé, Damien Flieller, Yves-André Chapuis, "A Unified Artificial Neural Network Architecture for Active Power Filters", IEEE Transactions on Industrial Electronics, Vol.54, No.1, February 2007, pp.61-76.
- [68] M.M.Abdel Aziz I, A.F.Zobaa I, A.A.Hosni, "Neural Network Controlled Shunt Active Filter For Non Linear Loads", MEPCON 2006, Eleventh International Middle East Power Systems Conference, 2006, Vol.1, pp.180-188.
- [69] Jianhua Wu, Hali Pang, Xinhe Xu, "Neural-Network-Based Inverse Control Method for Active Power Filter System", 2006 IEEE International Conference on Control Applications, 2006 IEEE International Symposium on Intelligent Control, 2006 IEEE Computer Aided Control System Design, pp.3094-3097.
- [70] H. C. Lin, "Adaptive Filtering for Unstable Power System Harmonics using Artificial Network", SMC '06, IEEE International Conference on Systems, Man and Cybernetics, 2006, Vol.2, pp.1325-1330.
- [71] Joy Mazumdar, Ronald G Harley, Ganesh K. Venayagamoorthy, "Synchronous Reference Frame Based Active Filter Current Reference Generation Using Neural Networks", IECON 2006 - 32nd Annual Conference on IEEE Industrial Electronics, pp.4404-4409.
- [72] Claudionor F. Nascimento, Azauri A. Oliveira Jr., Alessandro Goedel, Ivan N. Silva, "Compensation Current of Active Power Filter Generated by Artificial Neural Network Approach", IECON 2006 - 32nd Annual Conference on IEEE Industrial Electronics, pp.4392-4397.
- [73] Abdelaziz Zouidi, Farhat Fnaiech, Kamal AL-Haddad, Salem Rahmani, "Artificial Neural Networks as Harmonic Detectors", IECON 2006 - 32nd Annual Conference on IEEE Industrial Electronics, pp.2889-2892.
- [74] Ping Wang, Aiqin Xin, and Yu Zou, "Neural Network Hysteresis Control of three-phase Switched Capacitor Active Power Filter", ICPEA '06, 2nd International Conference on Power Electronics Systems and Applications, 2006, pp.256-259.
- [75] N.B.Muthuselvan, Subhransu Sekhar Dash, P. Somasundaram, "Artificial Neural Network Controlled Shunt Active Power Filter", 2006 Annual IEEE India Conference, pp.1-5.
- [76] D. Ould Abdeslam, P. Wira, D. Fliellert, J. Merckle, "Power harmonic identification and compensation with an artificial neural network

method", 2006 IEEE International Symposium on Industrial Electronics, Vol.3, pp.1732-1737.

- [77] Abdelaziz Zouidi, Farhat Fnaiech, Kamal AL-Haddad, "Neural Network controlled three-phase three-wire shunt active Power Filter", IEEE International Symposium on Industrial Electronics, Vol.1, 2006, pp.5-10.

- [78] A. Jaya Laxmi, G.Tulasi Ram Das, K.Uma Rao, K.Rayudu, "Comparison of PI and ANN Control Strategies of Unified Shunt Series Compensator", IEEE Power India Conference, 2006.



**S. Janpong** was born in Nan, Thailand, in 1972. He received his Bachelor degree in Electrical Engineering from Rangsit University (RSU) and Master degree in Electrical Engineering from King Mongkut's university of Technology North Bangkok (KMITNB). Currently, he is studying Ph.D. in Electrical Engineering at Suranaree University of Technology (SUT), Thailand. His research interest is harmonic elimination in the shunt active power

filter using an artificial neural network technique.



**K-L. Areerak** received the B.Eng, M.Eng, and Ph.D. degrees in electrical engineering from Suranaree University of Technology (SUT), Thailand, in 2000, 2003, and 2007, respectively. Since 2007, he has been a lecturer and Head of Power Quality Research Unit (PQRU) in the School of Electrical Engineering, SUT. He received the Assistant Professor in Electrical Engineering in 2009. His main research interests include active power filter, harmonic elimination, artificial intelligence applications, motor drive, and intelligence control systems.

active power filter, harmonic elimination, artificial intelligence applications, motor drive, and intelligence control systems.



**K-N. Areerak** received the B.Eng. and M.Eng degrees from Suranaree University of Technology (SUT), Nakhon Ratchasima, Thailand, in 2000 and 2001, respectively and the Ph.D. degree from the University of Nottingham, Nottingham, UK., in 2009, all in electrical engineering. In 2002, he was a lecturer in the Electrical and Electronic Department, Rangsit University, Thailand. Since 2003, he has been a Lecturer in the School of

Electrical Engineering, SUT. His main research interests include system identifications, artificial intelligence applications, stability analysis of power systems with constant power loads, modeling and control of power electronic based systems, and control theory.