

A Forward Automatic Censored Cell-Averaging Detector for Multiple Target Situations in Log-Normal Clutter

Musa'ed N. Almarshad, Saleh A. Alshebeili, and Mourad Barkat

Abstract—A challenging problem in radar signal processing is to achieve reliable target detection in the presence of interferences. In this paper, we propose a novel algorithm for automatic censoring of radar interfering targets in log-normal clutter. The proposed algorithm, termed the forward automatic censored cell averaging detector (F-ACCAD), consists of two steps: removing the corrupted reference cells (censoring) and the actual detection. Both steps are performed dynamically by using a suitable set of ranked cells to estimate the unknown background level and set the adaptive thresholds accordingly. The F-ACCAD algorithm does not require any prior information about the clutter parameters nor does it require the number of interfering targets. The effectiveness of the F-ACCAD algorithm is assessed by computing, using Monte Carlo simulations, the probability of censoring and the probability of detection in different background environments.

Keywords—CFAR, Log-normal clutter, Censoring, Probability of detection, Probability of false alarm, Probability of false censoring.

I. INTRODUCTION

THE signal returns from radar targets are usually buried in thermal noise and clutter. Target detection is commonly performed by comparing radar returns to an adaptive threshold such that a constant false alarm rate (CFAR) is maintained. The threshold in a CFAR detector is set on a cell by cell basis according to the estimated noise/clutter power, which is determined by processing a group of reference cells surrounding the cell under investigation. For example, the cell-averaging (CA)-CFAR processor adaptively sets the threshold by estimating the mean level in a window of N range cells. The detection performance of the CA-CFAR processor is optimum in a homogeneous background when the reference cells contain independent and identically distributed (IID) observations governed by an exponential distribution [1]. In practice, the environment is usually nonhomogeneous due to the presence of multiple targets and/or clutter edges in the reference window. In such situations, order statistics (OS)-detectors have been known to yield a good performance as

long as the nonhomogeneous background and outlying returns are properly discarded [2]. However, most of the work in the literature considers some type of censoring based on a priori knowledge or a judicial guess.

Some approaches [3-6] based on automatic censoring of unwanted cells have been proposed in the literature for Rayleigh clutter. In this work, we consider the problem of automatic censoring of unknown number of interfering targets in log-normal clutter. The main motivation behind the development of such an automatic censoring algorithm are due to the following: (i) as the resolution of radar increases, the amplitude statistics of clutter returns deviates from Rayleigh distribution and shows long-tail characteristics which, in many practical situations, can be modelled by log-normal distribution [7-8]; (ii) the automatic censoring algorithms developed for Rayleigh clutter may not straightforwardly be extended to the case where clutter samples are drawn from log-normal distribution. For example, the ordered data variability index based on which the detector of [6] has been developed may be difficult to use for automatic censoring in log-normal clutter because this index is highly dependent on the shape parameter of clutter distribution; a parameter difficult to estimate reliably in practice; (iii) the adaptive threshold of OS-CFAR processors is formally defined in terms of ranked samples of reference cells. To reduce the CFAR loss and improve the detection probability of log-normal OS-CFAR processors, the largest sample of ranked cells, involved in the computation of detection threshold, can be properly selected when the exact number of interfering targets is accurately determined. Therefore, the results of this research work have an attractive feature in that they add to the available log-normal CFAR detectors [9-13] the potential to determine and censor (efficiently) the unwanted targets samples in the reference window, which may cause an excessive number of false alarm or a poor probability of detection.

II. PRELIMINARIES

The general structure of the proposed CFAR processor is depicted in Fig. 1. The envelope-detected matched filter outputs Y_i are passed through a logarithmic processor and then sent serially into a tapped delay line of length $N+1$. The $N+1$ samples correspond to the even number N of reference cells $\{X_i : i = 1, 2, \dots, N\}$ surrounding the test cell X_0 .

Musaed N. Almarshad, Department of Electrical Engineering, King Saud University, Saudi Arabia (e-mail musaed20@yahoo.com).

Saleh A. Alshebeili, *IEEE Member*, Department of Electrical Engineering, King Saud University, Saudi Arabia (e-mail dsaleh@ksu.edu.sa).

Mourad Barkat, *IEEE Senior Member*, Department of Electrical Engineering, American, University of Sharjah, UAE (e-mail mbarkat@aus.edu).

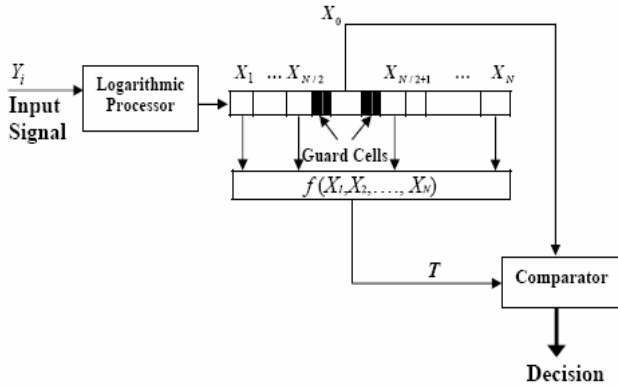

Fig. 1 Block diagram of the proposed CFAR processor

We assume that, if clutter alone is present (H_0 hypothesis), then Y_i are IID random variables drawn from log-normal probability density function (PDF) with scale parameter μ and shape parameter σ . Hence, the transformed variates X_i are of location-scale type, and precisely have the Gaussian distribution PDF; that is,

$$f(x, \mu, \sigma) = \frac{1}{\sqrt{2\pi}\sigma} \exp\left[-\left(\frac{x-\mu}{\sigma}\right)^2\right], -\infty < x < \infty \quad (1)$$

With an exact knowledge of the clutter parameters, the threshold ensuring a given probability of false alarm (P_{fa}) is given by

$$T = \mu + \gamma \sigma \quad (2)$$

where γ is the $(1-P_{fa})$ -quantile of the standard clutter distribution. However, lacking prior knowledge of the distributional clutter parameters, the adaptive threshold can be adjusted to take the form [10]

$$\hat{T} = \hat{\mu} + \hat{\gamma} \hat{\sigma} \quad (3)$$

where $\hat{\mu}$ and $\hat{\sigma}$ represent equivalent estimators of location and scale parameters, and $\hat{\gamma}$ is a suitable coefficient to be set according to the designed P_{fa} .

III. ESTIMATION OF LOCATION AND SCALE PARAMETERS

There are several ways [1,14] to obtain equivalent estimators of μ and σ , including maximum likelihood estimators (MLEs) and linear estimators such as best linear unbiased (BLU) and best linear invariant (BLI) estimators. Here, we focus on a simple linear approach which avoids solving nonlinear equations as in MLEs or the need for covariance matrix computations as in BLU and BLI estimators. Let

$$X(1) \leq X(2) \leq \dots \leq X(N) \quad (4)$$

be ordered samples of all reference window range cells. Linear estimators of μ and σ based on (possibly) $N-j$ censored samples from the upper end are defined as

$$\hat{\mu}_j = \sum_{i=1}^j a_i X(i) \quad (5)$$

$$\hat{\sigma}_j = \sum_{i=1}^j b_i X(i) \quad (6)$$

where a_i and b_i are suitable coefficients chosen to satisfy

$$\sum_{i=1}^j a_i = 1 \quad (7)$$

$$\sum_{i=1}^j b_i = 0 \quad (8)$$

which are necessary constraints for $\hat{\mu}_j$ and $\hat{\sigma}_j$ to be equivalent estimators. Define

$$S(1) \leq S(2) \leq \dots \leq S(j) \quad (9)$$

to be ordered variates from a Gaussian PDF which has zero mean and unit variance. Following the approach of [15], the coefficients a_i and b_i are determined as follows.

$$a_i = \frac{1}{j} - \frac{\bar{\alpha}(\alpha_i - \bar{\alpha})}{\sum_m (\alpha_m - \bar{\alpha})^2} \quad (10)$$

$$b_i = \frac{(\alpha_i - \bar{\alpha})}{\sum_m (\alpha_m - \bar{\alpha})^2} \quad (11)$$

where $\bar{\alpha}$ is the average value of $\{\alpha_i : i = 1, 2, \dots, j\}$ and

$$\begin{aligned} \alpha_i &= E\{S(i)\} \\ &= \int_{-\infty}^{\infty} x f_i(x) dx \end{aligned} \quad (12)$$

where $E\{\cdot\}$ is the expectation operation and $f_i(x)$ is the PDF of the variates $S(i)$. Denoting by $F(x)$ the cumulative distribution function (CDF) of the standard Gaussian PDF $f(x,0,1)$ of (1), the values of α_i can be computed as follows: [1]

$$\alpha_i = i \binom{N}{i} \int_{-\infty}^{\infty} x [1-F(x)]^{N-i} [F(x)]^{i-1} f(x,0,1) dx \quad (13)$$

The expectations α_i are the only estimates needed in the linear estimation method outlined above, and must be computed once and for all according to (13). Also, the resulting coefficients a_i and b_i given by (10) and (11) satisfy the conditions imposed by (7) and (8), respectively. Hence, $\hat{\mu}_j$ and $\hat{\sigma}_j$ are equivalent estimators.

For detection in homogeneous environments, it is appropriate to set $j=N$. However, when there are k interfering targets in the reference window, the value of j is best selected such that $j=N-k$. Therefore, our objective in this work is to develop a new censoring algorithm that has the task of determining the best value of k . Once the number of

interfering targets is determined automatically, the output of the cell under test X_0 is then compared with the adaptive threshold \hat{T} according to

$$X_0 \begin{matrix} > \\ < \end{matrix} \begin{matrix} H_1 \\ H_0 \end{matrix} \hat{T} \quad (14)$$

where the adaptive threshold \hat{T} (or equivalently the parameter $\hat{\gamma}$) is selected so that the design P_{fa} is achieved. H_1 denotes the presence of a target in the test cell, while hypothesis H_0 is the null hypothesis, i.e., no target is present

IV. THE PROPOSED CENSORING ALGORITHM

In this section, we propose a novel detector for automatic censoring of possible interfering targets that may lie in the reference window of the cell under test. The censoring procedure first ranks the outputs of all reference range cells in ascending order according to their magnitudes to yield

$$X(1) \leq X(2) \leq \dots \leq X(p) \leq \dots \leq X(N) \quad (15)$$

The proposed algorithm is termed, according to the sequence through which the censoring is performed, the forward automatic censored cell averaging detector (F-ACCAD). The basic idea of the F-ACCAD algorithm is to consider that the p lowest cells represent the initial estimation of the background level. The parameter p has to be carefully selected to yield a robust performance in both homogeneous background and non-ideal environment. Values of $p > N/2$, as in [6], have been found to yield a reasonable performance.

A. The F-ACCAD Algorithm

This algorithm proceeds as follows. Sample $X(p+1)$ is compared with the adaptive threshold \hat{T}_0 defined as

$$\hat{T}_0 = \hat{\mu}_p + d_0 \hat{\sigma}_p \quad (16)$$

where d_0 is a threshold coefficient chosen to achieve the desired probability of false censoring, P_{fc} . If $X(p+1) > \hat{T}_0$, the algorithm decides that $X(p+1)$ is a return echo from an interfering targets and it terminates. If, on the other hand, $X(p+1) < \hat{T}_0$, the algorithm decides that $X(p+1)$ corresponds to a clutter sample without interference. In this case, the algorithm proceeds to compare the sample $X(p+2)$ with the threshold

$$\hat{T}_1 = \hat{\mu}_{p+1} + d_1 \hat{\sigma}_{p+1} \quad (17)$$

to determine whether it corresponds to an interfering target or a clutter sample with interference. At the $(k+1)^{th}$ step, the sample $X(p+k+1)$ is compared with the threshold \hat{T}_k and a decision is made according to the test

$$X(p+k+1) \begin{matrix} > \\ < \end{matrix} \begin{matrix} H_1 \\ H_0 \end{matrix} \hat{T}_k \quad (18)$$

where $\hat{T}_k = \hat{\mu}_{p+k} + d_k \hat{\sigma}_{p+k}$, d_k is a constant chosen to achieve the desired P_{fc} , and $\hat{\mu}_{p+k}$ and $\hat{\sigma}_{p+k}$ are computed according to (5) and (6). Hypothesis H_1 represents the case where $X(p+k+1)$ and thus, the subsequent samples $X(p+k+2)$, $X(p+k+3)$, ..., $X(N)$ correspond to clutter samples with interference, while H_0 denotes the case where $X(p+k+1)$ is a clutter sample without interference. The successive tests are repeated while the hypothesis H_0 is true. The algorithm stops when the cell under investigation is declared nonhomogeneous (i.e. clutter plus interference sample) or, in the extreme case, when all the $N-p$ highest cells are tested; that is, $k=N-p$. Fig. 2 shows the block diagram of the F-ACCAD algorithm.

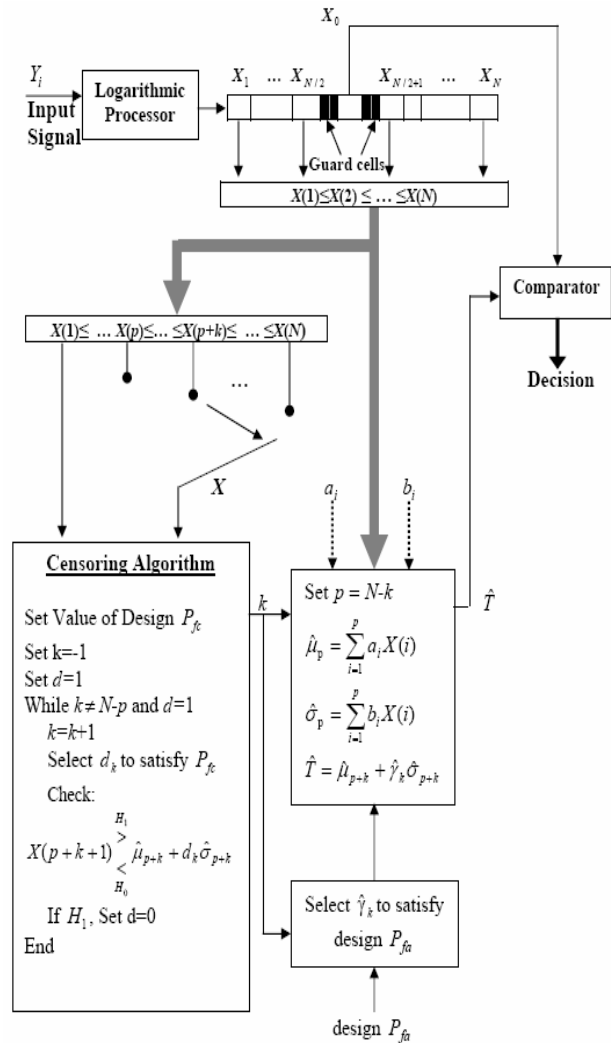

Fig. 2 Block diagram of the F-ACCAD algorithm

B. Selection of Detection Thresholds

The F-ACCAD algorithm requires knowledge of the threshold coefficients $\hat{\gamma}_k$ (or equivalently $\hat{\gamma}_{N-j}$, where $j=p$,

$p+1, \dots, N$). Table I gives the values of $\hat{\gamma}_{N-j}$ for different values of N and p . These coefficients are selected such that P_{fa} is maintained constant in a homogeneous environments. That is,

$$\text{design } P_{fa} = \text{Prob}\{X_0 > \hat{T}/H_0\} \quad (19)$$

Because an analytical expression for the PDF of \hat{T} is not available, the results of Table I have been obtained using Monte Carlo simulations with 500,000 independent runs. Note that as the value of p increases, the threshold coefficients $\hat{\gamma}_{N-j}$ decreases. This is intuitively not surprising because increasing the value of p increases the accuracy of estimating the clutter parameters μ and σ .

TABLE I
THRESHOLD COEFFICIENTS $\hat{\gamma}_{N-j}$ FOR DIFFERENT VALUES OF N

| (N,p) | $\hat{\gamma}_{N-j}$ | | | | | | | |
|---------|----------------------|------------------|------------------|------------------|------------------|------------------|------------------|------------------|
| | $\hat{\gamma}_7$ | $\hat{\gamma}_6$ | $\hat{\gamma}_5$ | $\hat{\gamma}_4$ | $\hat{\gamma}_3$ | $\hat{\gamma}_2$ | $\hat{\gamma}_1$ | $\hat{\gamma}_0$ |
| (16,12) | -- | -- | -- | 4.5 | 4.25 | 4.1 | 3.9 | 3.8 |
| (32,24) | 3.7 | 3.66 | 3.56 | 3.55 | 3.46 | 3.45 | 3.43 | 3.4 |

The F-ACCAD algorithm also requires the values of the thresholds d_k . These thresholds are determined such that a low probability of hypothesis test error e_k is achieved. Specifically, e_k is defined, at each value of k , as follows

$$e_k = \text{Prob}\{X(p+k+1) > \hat{T}_k/H_0\} \quad (20)$$

Monte Carlo simulations have been used to determine the values of threshold coefficient d_k by setting

$$e_0 = e_1 = \dots = e_k = \text{design } P_{fc} \quad (21)$$

and the result are displayed in Table II. It is of interest to note that the thresholds d_k form an ordered sequence with respect to k .

TABLE II
THRESHOLD PARAMETERS d_k IN A HOMOGENEOUS BACKGROUND WITH LOG-NORMAL PDF

| (N,p) | P_{fc} | d_k | | | | | | | | |
|---------|--------------------|-------|-------|-------|-------|-------|-------|-------|-------|--|
| | | d_0 | d_1 | d_2 | d_3 | d_4 | d_5 | d_6 | d_7 | |
| (16,12) | 10^{-2} | 1.75 | 2.07 | 2.565 | 3.58 | --- | --- | --- | --- | |
| | 5×10^{-3} | 1.94 | 2.275 | 2.79 | 3.92 | --- | --- | --- | --- | |
| | 10^{-3} | 2.39 | 2.76 | 3.37 | 4.70 | --- | --- | --- | --- | |
| (32,24) | 10^{-2} | 1.28 | 1.41 | 1.56 | 1.73 | 1.94 | 2.215 | 2.66 | 3.55 | |
| | 5×10^{-3} | 1.37 | 1.50 | 1.65 | 1.83 | 2.05 | 2.35 | 2.82 | 3.79 | |
| | 10^{-3} | 1.57 | 1.69 | 1.86 | 2.05 | 2.31 | 2.65 | 3.18 | 4.33 | |

V. PERFORMANCE EVALUATION

In this section, we evaluate the performance of the proposed F-ACCAD algorithm using different values of N and p and at different interference-to-clutter ratios (ICR). The complex

envelop of the received signal has been considered to have Rayleigh distributed amplitude and uniform phase. As far as one is concerned with single-hit detection, this corresponds to both Swerling I and Swerling II fluctuating models. We assume in our evaluation that the reference window contains m unknown targets, where $0 \leq m \leq N-p$ and $m=0$ corresponds to the homogeneous case.

A. Effect of Initial Population

The F-ACCAD algorithm has been developed under the assumption that the cell averaging samples, which define the thresholds \hat{T}_k , are clutter samples without interference. Note that the behavior of the algorithm may change according to whether the initial population is homogeneous or nonhomogeneous.

Let β be the probability that the initial population, defined by if, at least, the smallest cell containing an interference plus clutter is less than or equal to the p^{th} sample containing clutter only. When there is no interfering targets, $\beta=1$. In the presence of m interfering targets, the initial population cells $X(1), X(2), \dots, X(p)$ may contain interference plus clutter samples. Therefore, β can be defined as follows [6]

$$\beta = 1 - \text{Prob}(X_{i1} \leq X_{cp}) \quad (22)$$

where X_{i1} represents the smallest interfering target sample after the samples ranked in order, i.e., $X_{i1} \leq X_{i2} \leq \dots \leq X_{im}$ and X_{cp} denotes the p^{th} sample of the order statistics $X_{c1} \leq X_{c2} \leq \dots \leq X_{cp} \leq \dots \leq X_{c(N-m)}$ where X_{cj} , ($j=1, 2, \dots, N-m$), contains the clutter samples only.

The probabilities β obtained for different values of ICR and m , are presented in Table III. We observe that, when ICR increases, β remains close to 1 even when several interferences are present.

TABLE III
PROBABILITIES β THAT INITIAL POPULATION IS HOMOGENEOUS IN MULTIPLE TARGET SITUATIONS

| (N,p) | m | ICR | | | |
|---------|-----|--------|--------|--------|--------|
| | | 10dB | 20dB | 30dB | 40dB |
| (16,12) | 1 | 0.9494 | 0.9948 | 0.9995 | 0.9999 |
| | 2 | 0.8743 | 0.9862 | 0.9986 | 0.9998 |
| | 4 | 0.5431 | 0.9335 | 0.9929 | 0.9993 |
| (36,24) | 4 | 0.8420 | 0.9829 | 0.9982 | 0.9998 |
| | 8 | 0.5736 | 0.9432 | 0.9941 | 0.9994 |
| | 12 | 0.1197 | 0.7619 | 0.9721 | 0.9970 |

B. Probability of Censoring

Fig. 3 shows the probability of censoring for $N=36, p=24, \sigma=0.355$, and $m=8$ interferences with different ICR. P_{fc} has been fixed at 10^{-2} . Note that the F-ACCAD algorithm has the capability to determine the exact number of interferences with probability of 44% at ICR=25dB, and 45.5% at ICR=30dB. The algorithm is also characterized by a low probability of under-censoring (P_u) compared to that of over-censoring

(P_o). In practice, under-censoring may degrade the performance of the censoring algorithm, whereas over-censoring is a desirable property when the number of interferences is unknown [6].

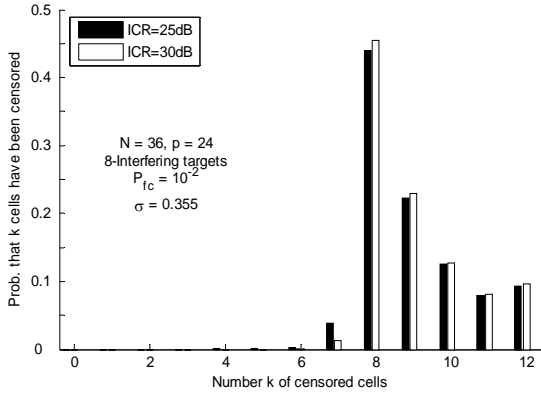

Fig. 3 Probability of censoring in multiple target situations

Fig. 4 shows the effect of the number of interfering targets on the performance of the F- ACCAD algorithm. The probability of under-censoring is computed for $m=2, 6$, and 10 interferences and displayed as a function of ICR. Note that for high and moderate levels of ICR, the probability of under-censoring is relatively small and insignificant compared to the probability of the event ($k \geq m$), which is equal to $(1 - P_u)$. For low levels of ICR, the number of interfering targets has a slight effect on the performance; the higher the value of m , the higher is the probability of under-censoring.

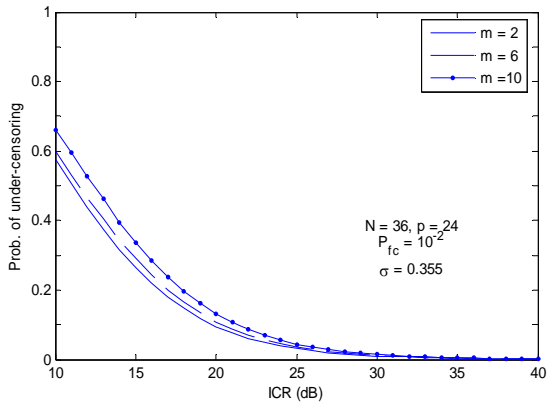

Fig. 4 Probability of under-censoring in multiple target situations

Fig. 5 shows the effect of the shape parameter σ on the performance of the F-ACCAD algorithm in the presence of $m=8$ interfering targets. The probability of under-censoring is computed as a function of σ and displayed for ICR=25 and 35dB. Note that, as σ increases, P_u also increases. However, the F-ACCAD algorithm has the potential to maintain relatively small values of P_u at high values of shape parameter σ .

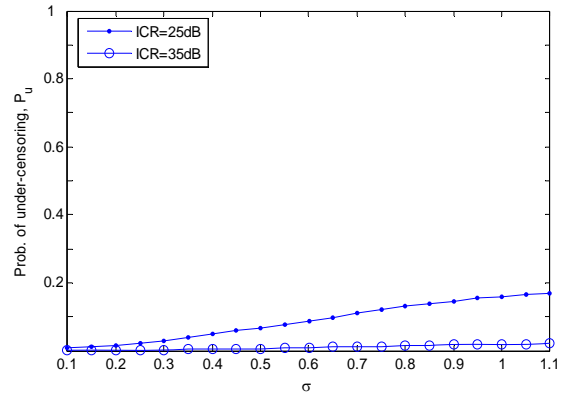

Fig. 5 Probability of under-censoring in multiple target situations

C. Probability of Detection

In this section, the detection performance of the F-ACCAD algorithm in log-normal clutter is evaluated. Single pulse detection is considered and a Rayleigh fading model is assumed for the fluctuating targets. Unless otherwise stated, the ICR has been set equal to signal-to-clutter ratio (SCR). That is, the outlying targets are assumed to have the same radar cross-section as the primary target. In Fig. 6 the detection performance of the F-ACCAD algorithm for $(N,p)=(36,24)$ and $(N,p)=(16,12)$ configurations in a homogeneous background is presented. The results are compared with that of the ideal processor whose detection threshold is adjusted according to (2). As the figure shows, the curve of the F-ACCAD algorithm closely matches that of the ideal detector when $(N,p)=(36,24)$. However, there is a slight degradation in algorithm's performance when $(N,p)=(16,12)$, which is expected and may be attributed to the small number of reference window samples exploited in estimating the unknown clutter distributional parameters.

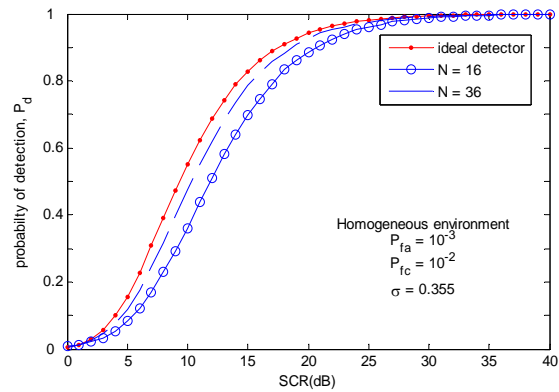

Fig. 6 P_d against SCR of F-ACCAD detector in homogeneous environments

In Fig. 7, the detection performance of the F-ACCAD algorithm in the presence of m interfering targets is presented. We note that as the number of interfering targets present in the reference window increases, the detection probability

decreases. However, this degradation in probability of detection is more pronounced at higher values of σ .

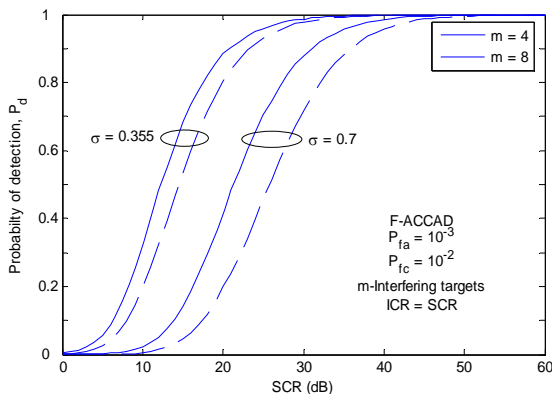

Fig. 7 P_d of F-ACCAD detector in multiple target situations for two values of σ

VI. SUMMARY AND CONCLUSION

In this paper, we have considered the problem of automatic censoring of unknown number of interfering targets in log-normal clutter. A novel technique has been proposed; namely, the F-ACCAD algorithm. This algorithm uses pre-computed thresholds to discriminate between homogeneous and nonhomogeneous populations in log-normal clutter. The effectiveness of the proposed F-ACCAD algorithm has been assessed by computing the probability of censoring and probability of detection for different numbers of interfering targets and at different values of ICR. Simulation results show that the proposed F-ACCAD algorithm performs robustly in the presence of high and moderate levels of interferences. The F-ACCAD algorithm is also characterized by having small probability of under-censoring and is capable to maintain good performance even at relatively high values of shape parameter σ .

ACKNOWLEDGMENT

This work is sponsored in part by the Research Center, College of Engineering, King Saud University.

REFERENCES

- [1] M. Barkat, *Signal Detection and Estimation*, 2nd ed., Norwood, MA:Artech House, 2005.
- [2] P.P. Gandhi and S. A. Kassam, "Analysis of CFAR Processors in nonhomogeneous Background," *IEEE Trans. Aerosp. Electron. Syst.*, AES-24, Vol. 24, No. 4, pp 427-445, July 1988.
- [3] S. D. Himonas and M. Barkat, "Automatic censored CFAR detection for nonhomogeneous environments," *IEEE Trans. Aerosp. Electron. Syst.*, Vol. 28, No. 1, pp. 286-304, Jan.1992.
- [4] R. Srinivasan, "Robust radar detection using ensemble CFAR processing," *IEE Proc., Radar Sonar Navig.*, Vol. 147, No. 6, pp. 291-297, Dec. 2000.
- [5] M. E. Smith and P. K. Varshney, "Intelligent CFAR processor based on data variability," *IEEE Trans. Aerosp. Electron. Syst.*, Vol. 36, No. 3, pp. 837-847, July 2000.
- [6] A. Farrouki and M. Barkat, "Automatic censoring CFAR detector based on ordered data variability for nonhomogeneous environments," *IEE Proc., Radar Sonar Navig.*, Vol. 152, No. 1, Feb. 2005.

- [7] J. B. Billingsley, A. Farina., F. Gini, M. V. Greco and Verrazzani, "Statistical analyses of measured radar ground clutter data," *IEEE Trans. Aerosp. Electron. Syst.*, Vol. 35, No. 2, pp. 579-592, Apr.1999.
- [8] D. A. Shnidman, "Generalized radar clutter model," *IEEE Trans. Aerosp. Electron. Syst.*, Vol. 35, No. 3, pp. 857-865, July 1999.
- [9] G. B. Goldstein, "False-alarm regulation in log-normal and Weibull clutter," *IEEE Trans. Aerosp. Electron. Syst.*, AES-9, No.1, pp. 84-92, Jan 1973.
- [10] M. Guida, M. Longo and M. Lops, "Biparametric CFAR procedures for lognormal clutter ", *IEEE Trans. Aerosp. Electron. Syst.*, Vol. 29, no.3, July 1993.
- [11] E. Conte, M. Lops and A. M. Tulino, "Hybrid procedure for CFAR in non-Gaussian clutter," *IEE Proc., Radar Sonar Navig.*, Vol. 144, No. 6, pp 361-369, Dec. 1997.
- [12] P. Weber and S. Haykin, "Ordered statistic CFAR processing for two parameter distributions with variable skewness," *IEEE Trans. Aerosp. Electron. Syst.*, Vol. AES-21, No. 6, pp. 819-821, Nov. 1985.
- [13] E. K. Al-Hussaini, "Performance of an ordered statistic CFAR processor in lognormal clutter," *IEE Electronic letters*, Vol.24, No.7, March 1988.
- [14] H. A. David, H. N. Nagaraja, *Order Statistics*, 3rd ed., John Wiley, Aug. 2003.
- [15] A. K. Gupta, "Estimation of the mean and standard deviation of a normal population from a censored sample," *Biometrika*, 1952.