

# A Design of the Organic Rankine Cycle for the Low Temperature Waste Heat

K. Fraňa, M. Müller

**Abstract**—A presentation of the design of the Organic Rankine cycle (ORC) with heat regeneration and superheating processes is a subject of this paper. The maximum temperature level in the ORC is considered to be 110°C and the maximum pressure varies up to 2.5MPa. The selection process of the appropriate working fluids, thermal design and calculation of the cycle and its components are described. With respect to the safety, toxicity, flammability, price and thermal cycle efficiency, the working fluid selected is R134a. As a particular example, the thermal design of the condenser used for the ORC engine with a theoretical thermal power of 179 kW was introduced. The minimal heat transfer area for a completed condensation was determined to be approximately 520m<sup>2</sup>.

**Keywords**—Organic Rankine Cycle, thermal efficiency, working fluids.

## I. INTRODUCTION

THE safety energy production at the acceptable price level becomes to be important subject worldwide. The basic demand of any national and international aim in the energy supply is to secure enough low price energy with sustainable aspect. The possible solution is to increase the thermal efficiency in the existing facilities. The maximal thermal efficiency reachable in the heat engine is given by the Carnot cycle theory. According to thermodynamics law, the thermal efficiency is defined by the ratio of the produced work and the amount of the heat delivered into the heat cycle. Eliminating of the waste heat, more heat can be transformed into electric output so that the higher thermal efficiency can be reached. In practice, the engine designed to be working with the lower temperature at the output must use working fluids with different material properties then classically used water. Those engines are called as an Organic Rankine cycle. Design of the new ORC engine is a subject of presented paper.

Historically, there are several more or less successful projects representing possibilities to benefit from the ORC engine. Saleh et al. [1] designed the ORC for already existing power plants in Altheim, Austria, with a power production of 1MWel. Leslie et al. [3] presented results of a project demonstrating the technical and economic feasibility of capturing thermal energy from a 27 MW gas turbine driving a natural gas pipeline compressor with a recovered energy

generation (REG), which is based on a modified organic Rankine cycle (ORC). The REG plant improved the overall energy efficiency by 28%, from 32% simple cycle efficiency to 41% for the combined system. The important step in any ORC design is a selection of the working fluid, which must be proposed in respect to the safe and economic ORC operation. Zyhowski et al. [2] described the properties of HFC-245fa and discussed its potential application in power generation systems. The commercially available Refrigeration Grade HFC-245fa meeting Air-Conditioning and Refrigeration Institute Standard 700 has provided a viable option for safe, flexible, and economically efficient conversion of waste heat to electric power using Organic Rankine Cycle technology. In a bottoming cycle, the advantages of HFC-245fa as compared to water include higher cycle efficiencies, lower latent heat-to-heat capacity ratio (heat exchange pinch point for water), and higher gas densities (lower volumes). Geothermal, solar, and industrial waste heat sources can be used to drive HFC-245fa as the working fluid in organic Rankine cycle systems in order to achieve useful thermal energy utilization via thermal energy conversion to electric power. The same working fluid was preferred in a performance analysis of ORC by Wei [5]. Mago [4] investigated effect of the fluid boiling point on the ORC performance for working fluids R134a, R113, R245ca, R245fa, R123, isobutene and propane. It was found that the boiling temperature has a significant effect on the thermal efficiency and working fluids must be selected based on the particular temperature conditions.

Some briefly overview about existing working fluids and basic theoretical knowledge can be found in section II. Section III describes basic calculus and techniques to design crucial components of the ORC system as well as determination of the thermal efficiency. Section IV summarizes significant results presented here.

## II. PROBLEM FORMULATION

There are several possible schemes of the Organic Rankine Cycle varying by the used components. Fig. 1 depicts a most complex cycle in which heat is regenerated leading to a higher thermal efficiency. Simultaneously, the part of the waste heat is delivered into superheater.

Therefore, this ORC's concept is composed by the vaporizer and superheater (2-6), regenerator (7-8) and condenser (1-9). The turbine or steam engine works between pressure levels  $p_1$  and  $p_2$ . This component is responsible for energy transformation into the mechanical work. The important aspect of the turbine or steam engine is to seal the

K. Fraňa is with the Technical University of Liberec, Department of Power Engineering Equipment, 461 17, Liberec, Czech Republic (phone: +420 48 535 3436; fax: +420 48 535 3434; e-mail: karel.frana@seznam.cz).

M. Müller is with the Technical University of Liberec, Department of Power Engineering Equipment, 461 17, Liberec, Czech Republic (phone: +420 48 535 3428; fax: +420 48 535 3434; e-mail: milos.muller@tul.cz).

working fluid. Scheme of the ORC with regeneration and superheating is illustrated in Fig. 2.

There are several works e.g. [1] which demonstrated under particular service conditions that the additional construction of the superheater in the ORC is leading to the non-significant increase of the thermal efficiency. Any additional component increases final expenditures needed for ORC's production.

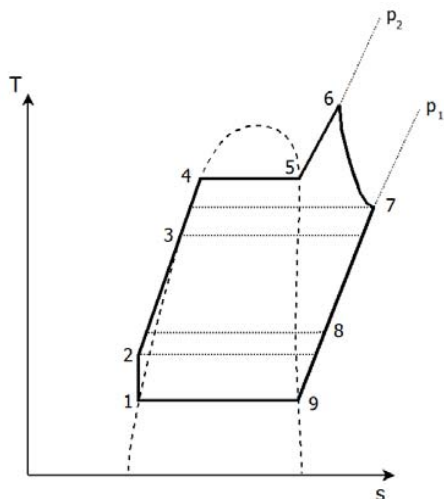

Fig. 1 T-s diagram of the ORC with the heat regeneration

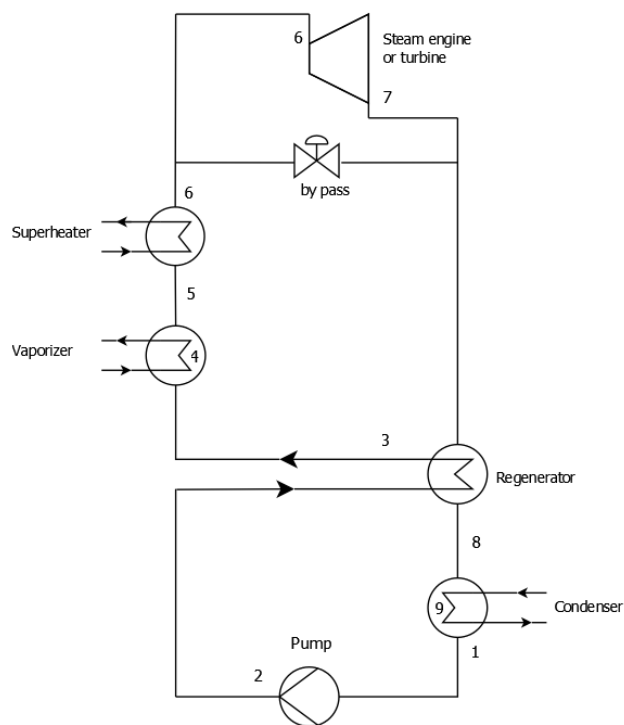

Fig. 2 The scheme of the ORC with a heat regeneration

Fig. 3 shows a saturation vapor region of several commonly used working fluids in the ORC. This group of fluids is for

higher critical temperature, particularly more than 150°C. The highest critical temperature is for Toluene (more than 300°C). Fig. 4 describes the saturation vapor region for working fluids with lower critical temperatures.

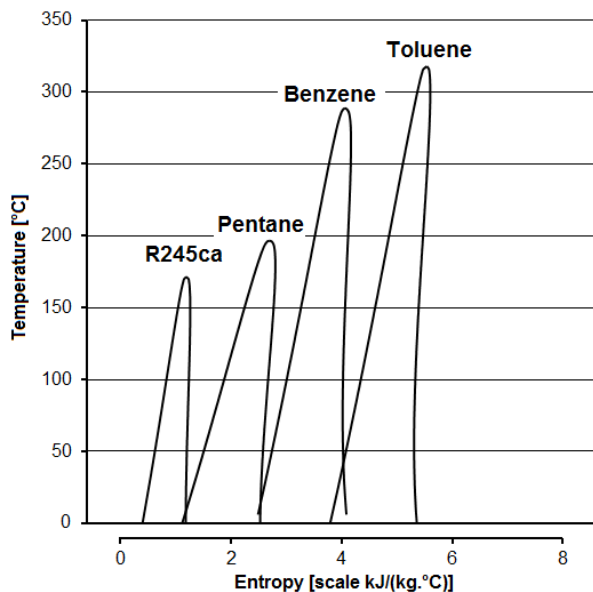

Fig. 3 Saturation vapor region of the working fluids: R245ca, Pentane, Benzene and Toluene

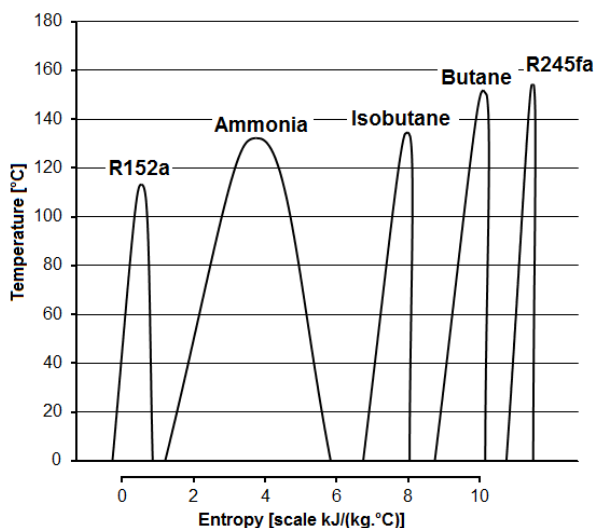

Fig. 4 Saturation vapor regions of the working fluids: R152a, Ammonia, Isobutane, Butane and R245fa

To find appropriate working fluids depends on various criterions. In the frame of this paper, the fluid study considered only such working fluids that are principally not toxic. Secondly, important criterion is efficiency of the proposal ORC. Tables I and II summarized selected working fluids.

The highest theoretical thermal efficiency of ORC can be reached if pentane is used as a working fluid. This fluid has

the higher critical temperature and efficiency reached up to 17%. The lower efficiency is for cycle which used working fluids with lower critical points, for instance, isobutane. The same conclusion was confirmed by Mago et al [4].

TABLE I  
CRITICAL POINTS AND TEMPERATURES OF SATURATIONS FOR SELECTED WORKING FLUIDS

media	critical point		temperature of saturation [°C]			
	T [°C]	p [MPa]	0.1 MPa	0.5 MPa	1 MPa	2 MPa
R245fa	154.1	3.63	14.6	62.7	89.8	122.0
R245ca	174.4	3.93	24.8	75.1	103.3	136.7
pentane	196.6	3.37	35.7	92.6	124.9	163.5
butane	151.0	3.80	-0.8	50.3	79.5	114.4
isobutane	134.7	3.63	-12.1	37.7	66.2	100.4

TABLE II  
FLAMMABILITY AND MAXIMAL THEORETICAL THERMAL EFFICIENCY OF ORC FOR VARIOUS WORKING FLUIDS

media	flamability	Ideal affectivity with regenerator			
		T [°C] admission	T [°C] condensation	p [MPa] admission	%
R245fa	NO	140	80	2	10.3
R245ca	NO	140	80	2	12.1
pentane	YES	180	80	2	17.4
butane	YES	140	80	2	10.2
isobutane	YES	140	80	2	6.5

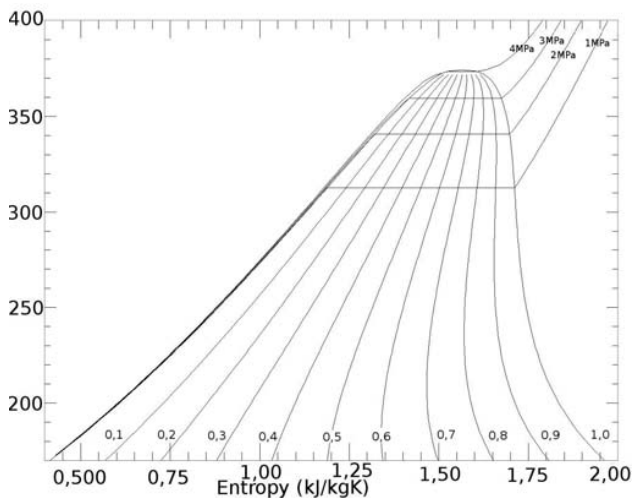

Fig. 5 T-s diagram of the working fluid R134a with isobar lines

Pentane, butane and isobutene belong to the fluids which are flammable so that their practical application is strictly limited. Other aspect for the working fluid selection is cost for purchasing. Particularly, in EU countries, there is a list of organic fluids which will be prohibited to use in the near future. This aim must be involved into selection process of the working fluids as well (see Tables I and II).

In our design of the ORC, the working fluid R134a was preferred to use. This fluid is economical, not flammable and no toxic with the future perspective. Fig. 5 shows the T-s diagram of the working fluid R134a with isobar lines starting

from 1MPa up to 4MPa. This refrigerant will expand from the pressure level of 2MPa to 1MPa in the heat engine and is further cooled up to saturation line and condensed. The calculation techniques for the size determination of the required condenser surface (heat exchanger) will be presented later.

### III. ASPECT OF THE COMPONENT DESIGN

The design of the cycle components is a task involving many technical aspects from the field of thermodynamics and fluid mechanics to the material engineering. However, the general aspects that have to be treated at the beginning are the future location of the cycle, seasons and the available heat source. This is a tricky question which can lead to some cycle limitation and changes in the cycle performance in time. The consideration of the surrounding conditions given by the cycle location and year time strongly influences heat exchangers design. Very low temperatures in winter lead to small heat exchanger surfaces and high temperatures in summer lead to very large heat exchanger surfaces. The planned heat source for the cycle determinates the heating phase of the working fluid and strictly limits the coolant operating temperatures. This has to be also considered in the sense of the cycle price and its size. The cycle size is important especially due to the transportation possibility to the available heat source.

The design, in general, includes two phases; preliminary design of the components and the selection of the components in market or its manufacturing. The preliminary design is usually based on thermodynamic calculations leading to the heat exchanger surfaces sizing, ventilator and the pump selection and the selection of a turbine or a steam engine. This phase gives parameters for the second phase which is the selection of particular components from the producer catalogue. Note that the selection of the component with parameters closest to the preliminary design is not necessary the best. The other aspects as the price and availability must be considered.

The heat source is usually specified by the working fluid type, its flow rate and the outlet temperature. This factor influences mainly the design of the boiler. The boiler usually consists from three parts. According to Fig. 4 they are the liquid phase heating up to the evaporation temperature, liquid evaporation inside the vaporizer and the vapor overheat inside the superheater.

This consideration is important due to different heat transfer coefficients in these regions. When using the hot air or exhaust gasses as the source fluid the heat amount of the heat transfer is driven by the heat transfer coefficient at this side. However, when using the source fluid in liquid or vapor phase the heat transfer is controlled by both the sites. Exact type of the boiler heat exchanger depends on the available heat source. Design parameters for the boiler are the mass flow rate of the working fluid, inlet and outlet temperatures of the working fluid, source inlet and outlet temperatures and the source mass flow rate.

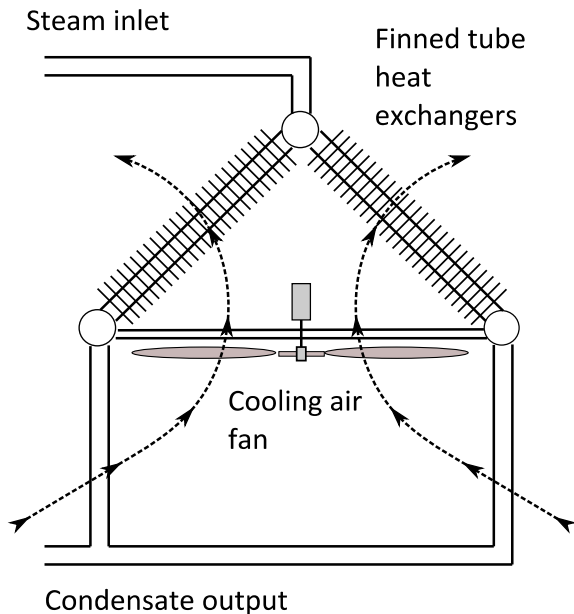

Fig. 6 Cooling tower (condenser) scheme

As the condenser usually a cooling tower is used. A basic scheme of dry cooling tower is shown in Fig. 6. Fundamentals regarding the design of cooling towers can be found in [6]. The cooling tower consists of a frame used for the fixation of heat exchangers and ventilators. The steam inputs into the heat exchangers in upper part of the tower. After the condensation the coolant in liquid phase leaves the cooling tower in lower part of the tower. As the coolant usually the air at temperature available at the location is used. The temperature of the cooling air can significantly change during the year time. Low temperatures in winter leads to large temperature difference between the cooled steam and the cooling air resulting in small heat exchange surfaces. The situation changes in summer time, when higher external temperatures can occur. The available temperature difference is small and the heat exchanger surfaces are large. Even in some time the outside temperature can be higher than the steam temperature and there is no temperature gradient available for the condensation. These time periods should be included in the payback calculations. It would be highly uneconomical to design the condenser heat exchanger surfaces for such an extreme temperature. The standard deviations in surroundings temperatures can be balanced by the utilization of air fan. It could be switched off in winter and regulated by a frequency changer during the summer. It is necessary to note, that the point when condensation finishes should be controlled by a temperature sensor. The lowering the temperature at this point decreases the efficiency of the cycle. As the heat transfer coefficient at the air side is generally low, the extended surfaces are used to increase heat transfer at the air side. Commonly finned tube heat exchangers are used for the condensers inside the cooling towers. Design parameters for the cooling tower are the mass flow rate of the working fluid,

inlet and outlet temperatures of the working fluid and the mass flow rate of the air and its temperature. The mass flow rate of the air is driven by the ventilator and can be regulated.

The pump determines the maximum (boiler) pressure inside the cycle. Due to relatively high mass flow rate and used organic fluid the pump presents relatively high investment even in small scale cycles. Design parameters for the pump are the mass flow rate of the working fluid, inlet and outlet pressures.

The regenerator is the smallest heat exchanger inside the cycle. It works with the same mass flow rate at both the sides, however the phases are different. The best solution is the plate heat exchanger, where the heat power is given by the number of sections. Design parameters for the regenerator are the mass flow rate of the working fluid, inlet and outlet temperatures at vapor and liquid side. From the construction point of view it is best to use soldered connections at both sides due to the possible coolant leakage.

The design of the steam engine or the turbine presents a task which details are outside the frame of this publication.

TABLE III  
EXAMPLE OF THE CYCLE ENGINE BALANCE

	Temperature C	Enthalpy kJ/kg	Pressure bar
Cycle point 1	40.0	256.4	10.2
Cycle point 2	41.7	258.6	35.0
Cycle point 3	54.0	277.0	35.0
Cycle point 4	93.7	351.9	35.0
Cycle point 5	93.7	422.2	35.0
Cycle point 6	110.0	458.5	35.0
Cycle point 7'	51.4	432.2	10.2
Cycle point 7	61.3	442.7	10.2
Cycle point 8	44.2	424.3	10.2
Cycle point 9	40.0	419.4	10.2
		Power kJ/kg	
Pump		2.1	
Turbine/Motor		15.8	
Condenser		167.9	
Boiler		181.5	
Regenerator		18.4	

However the most important parameter is the thermodynamic efficiency of this component. It must be determined from the measurement as its theoretical calculation especially for the steam engine based ORC is complicated. An example of the energy balance for ORC with motor efficiency of 60% is shown in Table III. Note that the energy wasted inside the condenser represents a certain potential for utilization. The large amount of the heat requires a large heat exchanger surface. Although the majority of the electricity inside the cycle is consumed by the pump also the energy consumed by the condenser fan should also be considered.

The calculation of the heat exchanger surfaces is usually based on common procedures depending on the data available. The method LMTD and e-NTU are applicable. However, in

the preliminary design phase all the input parameters can be defined or calculated from the energy balance (Table III) of the cycle so the LMTD method is most suitable. The LMTD method is based on following formula

$$Q = U \times A \times \Delta t, \quad (1)$$

where  $\Delta t$  is logarithmic mean temperature difference defined for counter current heat exchanger as

$$\Delta t_{LMTD} = \frac{\Delta t_1 - \Delta t_2}{\ln\left(\frac{\Delta t_1}{\Delta t_2}\right)} \quad (2)$$

where  $\Delta t_1$  is the temperature difference between the hot and cold fluids at one end of the heat exchanger and  $\Delta t_2$  is temperature difference between the hot and cold fluids at another end of the heat exchanger. The product  $UA$  can be after neglecting the heat conduction and fouling effect expressed as

$$U \times A = \left( \frac{1}{\eta_a \times h_a \times A_a} + \frac{1}{\eta_r \times h_r \times A_r} \right)^{-1} \quad (3)$$

In (3),  $h$  is heat transfer coefficient,  $A$  is surface,  $\eta$  is the surface efficiency and indexes  $a$  and  $r$  indicate air or refrigerant side. The surface efficiency is defined for the extended surfaces which is commonly applied at the air side only in form

$$\eta_a = 1 - \frac{A_f}{A_{total}} \times (1 - \eta_f). \quad (4)$$

In (4)  $A_f$  is the fin surface,  $A_{total}$  is total surface and  $\eta_f$  is the fin efficiency defined in e.g. in Kuppan [7]. The crucial point in the calculation of the heat transfer is the definition of the heat transfer coefficients. As the condensation starts in the overheated vapor region it is possible to separate the heat transfer calculation at the refrigerant side into two phases. The heat transfer coefficient can be obtained directly from Nusselt number, when an appropriate criteria relation is known. The Nusselt number for the single phase region can be calculated e.g. from this equation

$$Nu = 4.36 \quad (5)$$

for laminar region and e.g. from this equation

$$Nu = 0.023 Re^{0.8} Pr^{0.3}, \quad (6)$$

where  $Re$  is Reynolds number based on diameter and  $Pr$  is Prandtl number. For the two phases region in the condenser the heat transfer coefficient for the complete condensation can be defined according to Traviss [8] as

$$h_c = h_l \left( 0.55 + \frac{2.09}{Pr^{0.38}} \right), \quad (7)$$

where  $h_l$  is heat transfer coefficient for the liquid and  $p_r$  is reduced pressure. Note that the values of the heat transfer coefficients usually obtained from (7) are high and the heat transfer is therefore restricted by the heat transfer coefficient at the air side.

The Nusselt number definition at the air side depends on the flow characteristic and the tube pattern in the heat exchanger. For staggered tubes in regime  $10^3 < Re < 2 \times 10^5$  the following relation [9] can be used

$$Nu = 0.4 \times Re^{0.6} Pr^{0.36} \left( \frac{Pr}{Pr_w} \right)^{0.25} \quad (8)$$

where  $Pr_w$  is Prandtl number evaluated at the wall temperature. Note that the Reynolds number has to be evaluated at maximum velocity in the minimum flow area.

An example of the condenser calculation is shown in Table IV. The condenser is design for ORC with 179 kW of heat power. Based on this calculation, the construction of the real condenser is now in progress.

TABLE IV  
AN EXAMPLE OF THE CONDENSER DESIGN PARAMETERS FOR 179 KW  
THERMAL POWER

Condenser parameters		
Height	1.5	m
Width	1.5	m
Depth	0.76	m
Front surface	2.25	m <sup>2</sup>
Tube inner diameter	0.01	m
Tube outer diameter	0.012	m
Tube spacing x direction	0.03	m
Tube spacing y direction	0.03	m
Fin thickness	0.0005	m
Fin spacing	0.003	m
Number of ribs	498	
Front fins surface	0.249	m <sup>2</sup>
Front tube surface	0.6	m <sup>2</sup>
Heat transfer surface	521.4	m <sup>2</sup>

#### IV. CONCLUSION

Significant parameters relating to the design of the Organic Rankine Cycle engine were introduced and analyzed. The ORC design involves choice of the working fluids which has to be carried out in respect to the economical conditions, safety and thermal efficiency. For our particular ORC design, the working fluid R134a was selected. Furthermore, the cycle is composed by different components, for instance, the condenser, vaporizer, superheater, pump etc. The most complex heat engine is represented by the heat regeneration and with the superheating process. Particularly, the thermal design of the condenser was introduced in the paper. For heat cycle with the theoretical thermal power of 179 kW, the

condenser surface for the heat transfer must be equal or greater than  $521\text{m}^2$ . However, this surface determination considered constant parameters, particularly, temperatures and pressures which are not varying. In reality, these parameters will be affected by other outside aspects and would not be kept constant. Therefore, the efficiency of the whole cycle, as well as, requirements for component size will be varying.

Nowadays, our design of the ORC's components has been finished. The construction of the cycle components is now in progress. The first test running of ORC engine is planned for the beginning of the next year.

#### ACKNOWLEDGMENT

This work was financially supported from the project of the Technology Agency of the Czech Republic under no. TA02020716. This work was also supported by the European Project CZ.1.07/2.3.00/20.0139 "Building of an excellent scientific team necessary for experimental and numerical modeling of fluid mechanics and thermodynamics".

#### REFERENCES

- [1] B. Saleh, G. Koglbauer, M. Wenland a J. Fischer, Working Fluids for Low-Temperature Organic Rankine Cycles, *Energy* 32 (2007), 1210-1221, doi:10.1016/j.energy.2006.07.001
- [2] G.J. Zyhowski, A. P. Brown a A. Achaichia, HFC-245fa Working Fluid in Organic Rankine Cycle: A Safe and Economic Way to Generate Electricity from Waste Heat. 2010.
- [3] Neil P. Leslie, Ohad Zimron, Richard S. Sweetser, Therese K. Stovall, PE, Recovered Energy Generation Using an Organic Rankine Cycle System.
- [4] P.J., Mago, L.M., Chamre and C. Somayaji. Performance Analysis of Different Working Fluids for Use in Organic Rankine Cycles. *Proc. IMECHE*, Vol. 221, Part A: J. Power and Energy (2007), 255-264. DOI: 10.1243/09576509JPE372.
- [5] D. Wei, X. LU, Z. Lu a J. Gu, Performance Analysis and Optimization of Organic Rankine Cycle (ORC) for Waste Heat Recovery. *Energy Conversion and Management* 48 (2007), 1113-1119. DOI: 10.1016/j.enconman.2006.10.020.
- [6] D. K. Detlev, Air-Cooled Heat Exchangers and Cooling Towers: Thermal-Flow Performance Evaluation and Design.
- [7] T. Kuppan, Heat Exchanger Design Handbook, CRC Press, 2000.
- [8] Traviss, D. P., Rohsenow, W. M., Baron, A.B. Forced-Convection Condensation inside Tubes: A Heat Transfer Equation for Condenser Design. *ASHRAE Transactions* 1972.
- [9] F. P. Incropera, D.P. DeWitt, L. T. Bergman, and A.S. Lavine, *Fundamentals of Heat and Mass Transfer*, John Wiley & Sons, 6th Edition, 2007.