

A Comprehensive Evaluation of IGBTs Performance under Zero Current Switching

Ly. Benbahouche

Abstract—Currently, several soft switching topologies have been studied to achieve high power switching efficiency, reduced cost, improved reliability and reduced parasites. It is well known that improvement in power electronics systems always depend on advanced in power devices. The IGBT has been successfully used in a variety of switching applications such as motor drives and appliance control because of its superior characteristics.

The aim of this paper is focuses on simulation and explication of the internal dynamics of IGBTs behaviour under the most popular soft switching schemas that is Zero Current Switching (ZCS) environments.

The main purpose of this paper is to point out some mechanisms relating to current tail during the turn-off and examination of the response at turn-off with variation of temperature, inductance L , snubber capacitors C_s , and bus voltage in order to achieve an improved understanding of internal carrier dynamics. It is shown that the snubber capacitor, the inductance and even the temperature controls the magnitude and extent of the tail current, hence the turn-off time (switching speed of the device).

Moreover, it has also been demonstrated that the ZCS switching can be utilized efficiently to improve and reduce the power losses as well as the turn-off time. Furthermore, the turn-off loss in ZCS was found to depend on the time of switching of the device.

Keywords—PT-IGBT, ZCS, turn-off losses, dV/dt .

I. INTRODUCTION

THE insulated gate bipolar transistor (IGBT) was introduced into the family of power devices to overcome the high on-state loss while maintaining the simple gate drive requirements of power Mosfet. The IGBT combines both the Mosfet and the bipolar structures and possesses the best features of both device types.

This paper aims to present results of a simulation investigation about the behaviour of IXGH40N60A for IXYS family [10] under ZCS conditions using a two dimensional numerical simulation (Spice, Pspice). The main good of this investigation is to identify and demonstrate the performance of the device by the following turn-off time, tail current, current gain of PNP transistor and losses.

A schematic of the structure of two of several thousand cells of a PT-IGBT is shown in Fig. 1.

II. ZERO CURRENT SWITCHING ZCS

In this section, it is really important to understand the internal dynamics of PT-IGBT (IXGH40N60A) during ZCS turn-off. ZCS switching simulation have been performed using

a test circuit shown in Fig. 2 (a). Four phases (times) are chosen to extract some internal physical parameters to the structure of component focusing on the turn-off dynamics of IGBTs. The operation of the tester is illustrated with the help of Fig. 2 (b) where main waveforms are reported.

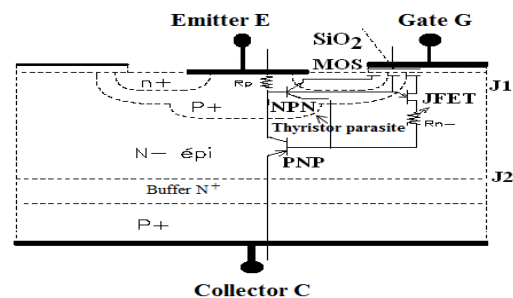

Fig. 1 Cross-sectional diagram indicating voltages and currents [1]-[4]

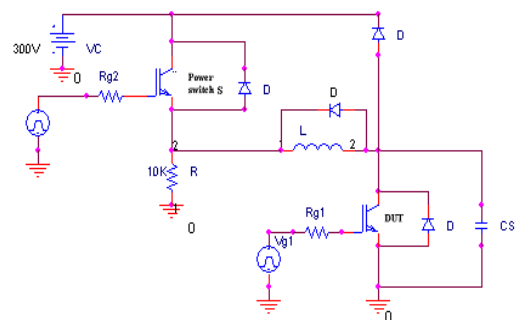

Fig. 2 (a) Test circuit to study IGBT behavior under ZCS conditions [2], [3]

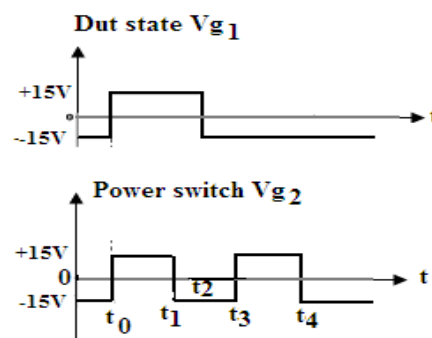

Fig. 2 (b) Tester operations [2]

Ly. Benbahouche is with the Electronics Department and EBT Department Faculty of Technology University Ferhat Abbas Setif1, Algeria (e-mail: lybenbah@yahoo.fr).

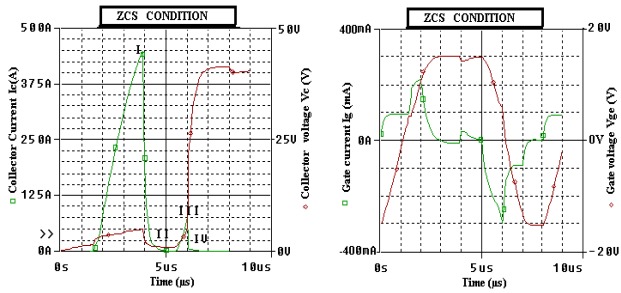

Fig. 2 (c) I_c , V_{ce} , I_g , V_{ge} waveforms for IXGH40N60A under ZCS conditions

At time $t=t_0$, the DUT and the switch S are turned on simultaneously, this first phase (I) corresponds to on-state operating device.

At $t=t_1$, the switch is opened, resulting the remove of current through the DUT. Device current abruptly falls to zero, but the DUT is in its on-state. This second phase (II) corresponds to zero current regime. At $t=t_2$, the DUT is turned off and still in the ZCS regime. After that and exactly at time t_3 the third phase (III) begins and corresponds to the close of the switch again, the inductor force current to flow through the snubber capacitors, leading to a rise in the device voltage and a tail current is observed (see Fig. 9). The last phase (IV) corresponds to the drop off of current when most of charge has decayed in a recombination dominated [2]-[5].

Also simulation results shows a rather dramatic drop between the first phase I and the second phase II, where carriers are also decaying due to recombination.

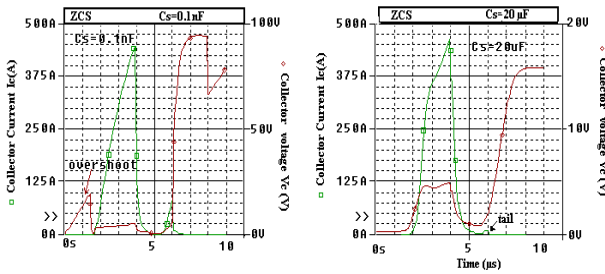

Fig. 3 (a) I_c , V_{ce} waveforms for IXGH40N60A under ZCS condition for different values of C_s

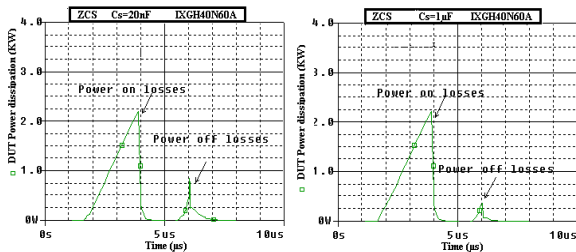

Fig. 3 (b) DUT power dissipation characteristics under ZCS condition for IXGH40N60A at $C_s=1\mu F$ and $C_s=20nF$

As there is a huge power loss within the device during ZCS operating condition, the inductor, the snubber capacitor and

the temperature are expected to have a significant impact on the device characteristics [6]-[9]. Thus, the choice of C_s , inductance L and the temperature have a similar influence on the turn-off performance under ZCS. Hence, ZCS turn-off involves charge removal from the drift region during the no current regime. On the other hand, ZCS turn-off involves a significant time interval of no external current. During this phase, charges are being removed from the drift region. Furthermore, DUT is turned off; carriers are also flushed out through the channel [7], [8].

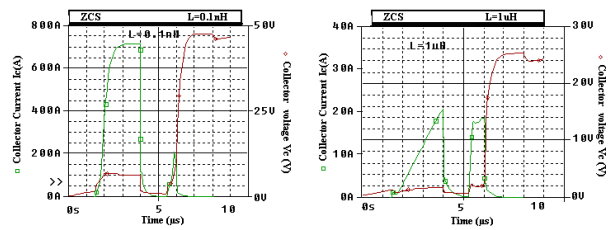

Fig. 4 (a) I_c , V_{ce} waveforms for IXGH40N60A under ZCS condition for different values of L

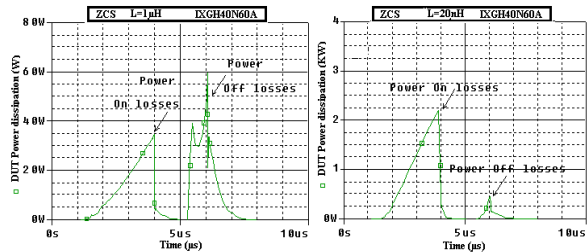

Fig. 4 (b) DUT power dissipation characteristics under ZCS condition for IXGH40N60A at $L=1\mu H$ and $L=20nH$

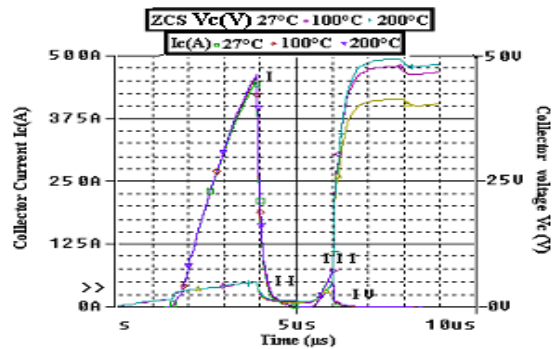

Fig. 5 (a) I_c , V_{ce} waveforms for IXGH40N60A under ZCS condition for different values of temperature

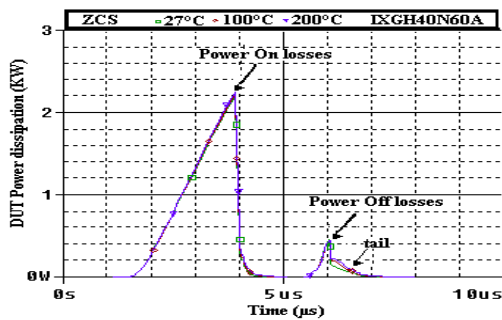

Fig. 5 (b) DUT power dissipation characteristics under ZCS condition for IXGH40N60A at 27°C, 100°C, and 200°C

III. CONCLUSION

In this paper a detailed comparative numerical study performance for actual PT-IGBTs for IXYS in soft switching conditions ZCS conditions. It has also been demonstrated that, the inductance L, the snubber capacitors, and the temperature have a strong influence on IGBT turn-off characteristics.

The main conclusions, which can be made from the present study, are:

- It was found that with increasing Cs, L and Temperature, the ΔI_c (initial drop) collector current decreases, hence turn-off time increase. These affect greatly the switching speed of the device. Then if we select an appropriate values of Cs, L and even temperature, the turn-off time can be reduced to the smallest values.
- In increasing temperature, the current of PNP transistor increase. This leads to higher concentration excess trapped charge and hence to a reduction in dV/dt capability.
- The power losses under ZCS can also been influenced by circuit in construction with varying of inductance. In this paper, we are verified and clarified that the construction with large inductance is suggested. This would support switching –off.

REFERENCES

- [1] JayantBaliga B., "Modern power devices", Schenectady, New York: General Electric Company; 1987, December.
- [2] M.Trivedi and K. Shenai, "Internal dynamics of IGBT under zero voltage switching and zero current switching conditions", *IEEE. Trans. Electron. Devices*, Vol.46, June.1999, pp. 1274-1281.
- [3] D. M. Divan, "The resonant dc link converters "A new concept in static power conversion in", *IEEE. Ind. ApplAnnu. Meeting Rec 1986 pp. 648-656* cited by [2].
- [4] Ly.Benbahouche, "Modeling and simulation the steady state and transient characteristics of the power Insulated Gate Bipolar" *Master Thesis U.F.A, Setif, Algeria 1996*.
- [5] M.Trivedi and K. Shenai, "Modeling the turn-off of -IGBT's in hard soft switching applications", *IEEE. Trans. Electron. Devices*, Vol.44, May.1997, pp. 887-893.
- [6] T. Paul. Chow, David Lau, "Performance of 600V n-channel IGBTs at low temperatures", *IEEE. Electron. Devices Letters*, Vol.12, N09, Sep.1991, pp. 498-499.
- [7] K.Wang, F.C.Lee, G.G.Hua, and Borojevic, "A comparative study of switching losses of IGBT's under hard-switching, zero voltage switching and zero current switching", in *Proc. IEEE Power Elec. Spec. Conf.*, 1994, pp.1196-1204.

- [8] M.Trivedi, R.Evazians, and K. Shenai, "Test circuits for characterizing power transistors in ZVS and ZCS circuits", in *IEEE. Instrum. Meas. Tech. Conf. Proc.*, 1998, pp. 515-518.
- [9] A.Elasser, M.Schutten, V.Vlatkovic, D.Torrey and M.Kheraluwala, "Switching losses of IGBT's under zero voltage and zero current switching", in *Proc. IEEE Power Elec. Spec. Conf.*, 1996, pp.600-607.
- [10] Fuji IGBT Data Book, 1994.