

# Development of a Feedback Control System for a Lab-Scale Biomass Combustion System Using Programmable Logic Controller

Samuel O. Alamu, Seong W. Lee, Blaise Kalmia, Marc J. Louise Caballes, Xuejun Qian

**Abstract**—The application of combustion technologies for thermal conversion of biomass and solid wastes to energy has been a major solution to the effective handling of wastes over a long period of time. Lab-scale biomass combustion systems have been observed to be economically viable and socially acceptable, but major concerns are the environmental impacts of the process and deviation of temperature distribution within the combustion chamber. Both high and low combustion chamber temperature may affect the overall combustion efficiency and gaseous emissions. Therefore, there is an urgent need to develop a control system which measures the deviations of chamber temperature from set target values, sends these deviations (which generates disturbances in the system) in the form of feedback signal (as input), and control operating conditions for correcting the errors. In this research study, major components of the feedback control system were determined, assembled, and tested. In addition, control algorithms were developed to actuate operating conditions (e.g., air velocity, fuel feeding rate) using ladder logic functions embedded in the Programmable Logic Controller (PLC). The developed control algorithm having chamber temperature as a feedback signal is integrated into the lab-scale swirling fluidized bed combustor (SFBC) to investigate the temperature distribution at different heights of the combustion chamber based on various operating conditions. The air blower rates and the fuel feeding rates obtained from automatic control operations were correlated with manual inputs. There was no observable difference in the correlated results, thus indicating that the written PLC program functions were adequate in designing the experimental study of the lab-scale SFBC. The experimental results were analyzed to study the effect of air velocity operating at 222-273 ft/min and fuel feeding rate of 60-90 rpm on the chamber temperature. The developed temperature-based feedback control system was shown to be adequate in controlling the airflow and the fuel feeding rate for the overall biomass combustion process as it helps to minimize the steady-state error.

**Keywords**—Air flow, biomass combustion, feedback control system, fuel feeding, ladder logic, programmable logic controller, temperature.

## I. INTRODUCTION

THE continuous problems arising from the industrial and commercial production and consumption of fossil fuels (such as petroleum, coal, natural gas) which have limited availability, increasing fuel prices with high amounts of gaseous pollutants and toxic substances polluting the atmosphere have led researchers to seek alternative energy supply, which is clean, affordable and renewable. Combustion technology has been a major approach for producing

alternative energy for a long period of time, which involves burning of energy fuel in air at very high temperatures to produce carbon-dioxide, water in form of steam, heat among other emitted flue gases.

The use of Fluidized Bed Combustors (FBCs) have attracted interest for generating industrial power and steam because of their ability to burn low-grade fuels while maintaining strict emission standards nowadays. FBCs have several advantages over conventional boilers viz: the rapid circulation of the solids in the bed which provides almost isothermal conditions and excellent heat transfer characteristics, the continuous movement of solids minimizes the formation of stagnant zones in the bed and ensures effective gas-solid contacting, mechanically simple and suited for large scale operations [1], FBCs produce smaller amounts of nitrogen oxides than conventional boilers due to the well-controlled temperature ranges and staging air implementation [2]. Similarly, the sulfur dioxide formed in the combustion bed is being absorbed by the addition of limestone [2]. Due to its high temperature demand for operations, low level gaseous emitted pollutants can be easily maintained in the FBCs. The disadvantages of this kind of combustor cannot be underestimated regardless of its numerous benefits. FBCs have coupled dynamics and severe nonlinearities that have frustrated attempts to effectively automate their operation using conventional control techniques [3], especially during start-up. FBC operation in the past has depended on frequent human intervention.

Control systems mostly used in industrial applications are of two types: Feedforward or feedback. Feedforward Control system is proactive in that it measures the disturbance in a system before it influences the system by generating a control signal that counteracts the disturbance whereas the feedback control system reacts to the effect of the disturbance on the system by taking corrective actions [4]. The difficulty in a feedforward control system is that the effects of the disturbance must be accurately predicted without any unmeasured disturbance within the system. According to [5], feedback control systems often use a specified function to control the output based on the reference input to the system. The controller gain is being amplified to regulate the process in order to reduce the steady state error. Thus, the theory of output signal feedback into a system has been fundamental for the design and analysis of a control system.

The use of combustion technologies has gained popularity over the years as an efficient means of processing biomass and

Samuel Oludayo Alamu is with the Morgan State University, United States (e-mail: olala22@morgan.edu).

solid wastes into useful energy in form of heat and electricity. Other technologies for biomass conversion through burning include gasification and pyrolysis at varying elevated temperatures.

Several researchers had compared the process to landfilling [6] and other biochemical processes and had concluded that the process is economically viable and socially acceptable in that there is no methane production from the overall process. But of major concerns are the environmental impacts of the process in terms of emission. A low chamber temperature results in incomplete combustion which in turn generates a high amount of carbon monoxide (CO). Similarly, there is a significant effect of combustion chamber temperature on nitrogen oxides (NO<sub>x</sub>) emissions. As temperature increases, the amount of emitted NO increases while N<sub>2</sub>O decreases [7]. On the contrary, low combustion temperature decreases the formation of NO<sub>x</sub>. Air fuel ratio of agriculture biomass (e.g. poultry litter) and air has been found as one of the important factors to control combustion temperature [8].

For the biomass FBC to be an economical energy system, there must be a high degree of automation involved in the process. A feedback control system which reacts to the effect of disturbance on the plant operations is required to correct steady state errors generated within the system. The aim of this research paper is to develop a temperature-based feedback control system for regulating the fuel feeding rate and the air

flowrate into a biomass combustion chamber.

## II. METHODOLOGY

### A. Lab-Scale Set-Up of FBC

Fig. 1 shows the lab-scale FBC used in the MSU CAESECT lab having a diameter of 304.8 mm and a height of 1500 mm. The chamber was fabricated with a carbon steel pipe covered inside with a 12.7 mm thickness refractory ceramic. The primary air for combustion is supplied at the bottom of the chamber at varying speeds. Above this line, the feed (poultry litter) is introduced from a screw feeder at a varying rate and the secondary air lines are introduced tangentially to the bed at heights 650 mm, 850 mm and 1100 mm, respectively [8], [9]. The heat recovery system installed involves the use of a shell and tube heat exchanger to condense the total heat generated, which passes through a set of connected pipes to four radiators placed in an empty mobile trailer to simulate space heating process. Poultry litter is being collected from poultry farms in Chesapeake Bay's Delmarva area of Maryland. The collected waste with 20-25wt.% moisture content is combusted with natural gas in the lab-scale bubbling FBC at 80:20% ratio. There are eight channel thermocouples inserted at different heights in the chamber to monitor the temperature distribution.

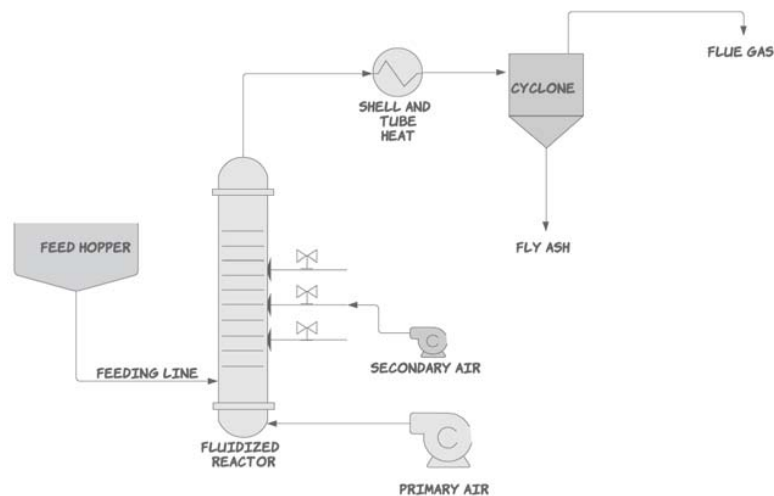

Fig. 1 Schematic Diagram of Experimental Setup for the Lab-Scale SFBC

### B. Programmable Logic Controller (PLC)

PLC is an industrial computer control system that continuously monitors the state of input devices and makes decisions based upon a custom program to control the state of output devices. Almost any production line, machine function, or process can be greatly enhanced using this type of control system. One of the biggest benefits in using a PLC is the ability to change and replicate the operation or process while collecting and communicating vital information.

Another advantage of a PLC system is that it is modular as it can mix and match the types of Input and Output devices to

best suit different application. PLC is a multipurpose general controller which can have one or more proportional-integral-derivative (PID) controller among other controllers being implemented in it. The steady state error is being observed and corrected by the PID algorithms. In general, the PID controller perceives the proportion, integral and derivative of the error in order to determine both the magnitude and the time required to correct the error [10]. There are two most common used programming languages used in PLC viz: Ladder Logic and Function Block. The former was used in this research having a block diagram as shown in Fig. 2. Function block diagrams

can essentially convert several lines of ladder logic into boxes.

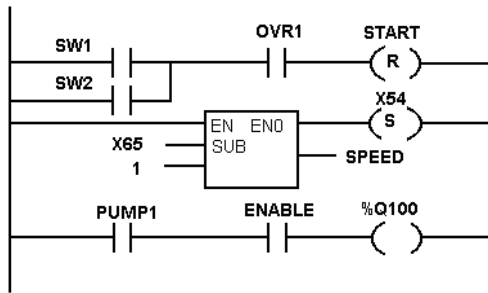

Fig. 2 Ladder Logic Programming Language [11]

The PLC used for this research is S7-1200. This comprises of both hardware and software components. The software being used is called Totally Integrated Automation (TIA portal) for Siemens automation control. The hardware components are CPU, Temperature Input card and Analog devices output card. The CPU 1212C/AC/DC/Relay consists of 7 digital inputs, 2 analog inputs, 5 digital outputs and no analog output. The analog/digital I/O module labeled ‘5’ consists of SM1231 TC and SM 1232 AQ. The SM 1231 TC is an input module connected to the 1212C/AC/DC/RELAY to read temperature input signals in either degree Celsius or Fahrenheit. The SM 1231 TC supports 4 thermocouples each of type J, K, T, E, R,

S, and N respectively. The SM 1232 AQ is an analog output module connected to the input TC module, capable of reading 4 output parameters.

The feeder line was connected to the analog output module. A 3-phase 230V blower is required for varying the speed of the blower using the PL controller as opposed to a single phase 115/120V. As shown in Fig. 3, the 230V 3-phase blower/fan was connected line by line to a V20 variable Frequency Drive. The K-type thermocouple sensor used in this feedback control system was positioned above the primary air and fuel feeding inlets.

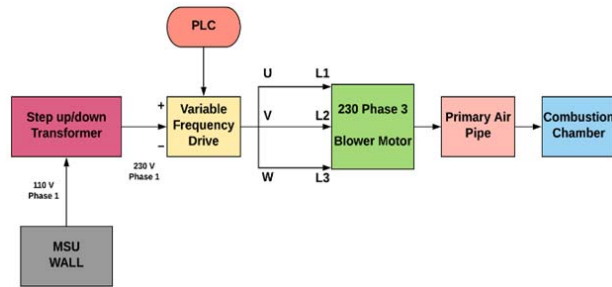

Fig. 3 Block Diagram for PLC Hardware Components Setup

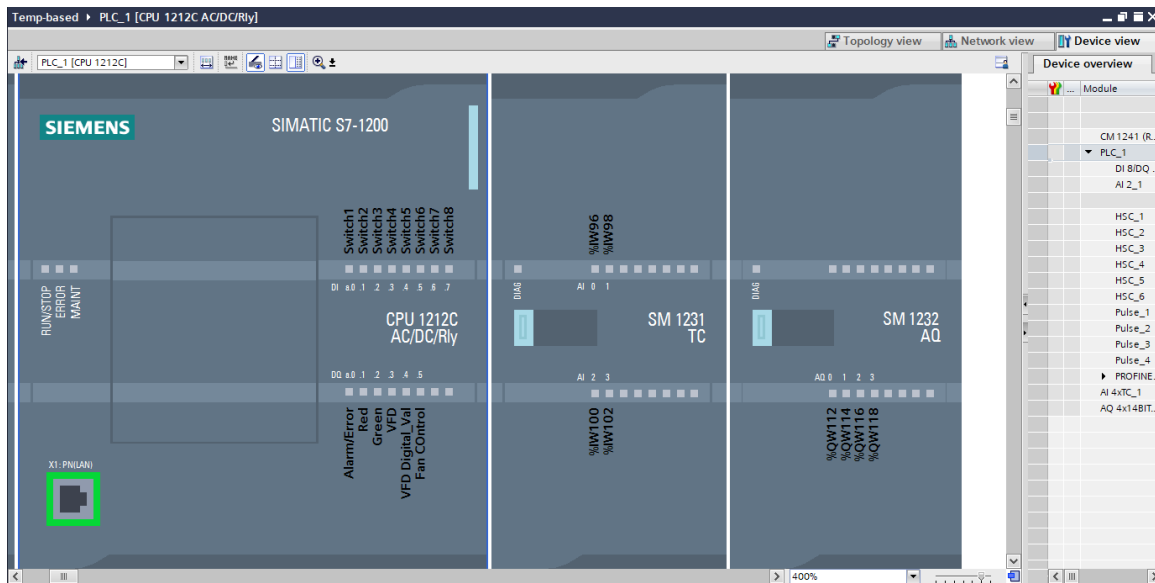

Fig. 4 PLC Devices Assigned Tags

The PLC device was assigned tags as shown in Fig. 4 where: (1) CPU 1212C AC/DC/Rly consists of the digital and analog I/O devices. %I (0.0-0.7) are operands assigned to the seven digital inputs (switches) to the PLC, %Q (0.0-0.5) are operands assigned to 5 digital outputs from the PLC CPU 1212C. (2) SM 1231TC is the temperature sensors input card being assigned to tags %IW (96,98,100 and 102). The temperature sensor used for the feedback signal was assigned

the tag %IW96. (3) SM 1232AQ is the analog output card. This can handle four analog devices with tags %QW (112, 114, 116 and 118). The VFD V20 Sinamics which controls the blower motor was assigned to the tag %QW112 and the fuel feeding motor was assigned to tag %QW116.

C. Experimental Setup

The process flowchart shown in Fig. 5 is a diagrammatic representation of the manual operation that is currently in use

in the lab. The goal is to keep adjusting the fan speed every time the temperature drops and the Feeder's rate under a steady increase in the chamber temperature. However, if the temperature can reach the desired temperature (800-900 °C), then the operation will be running continuously for 20 minutes or more.

The feedback control system algorithm was developed to mimic the manual operation sequences with a setpoint chamber temperature of 800-900 °C. The temperature-based PLC controller was programmed to measure the deviation from the setpoint and correct the system input such as the air velocity and the fuel feeding rate as shown in Fig. 6.

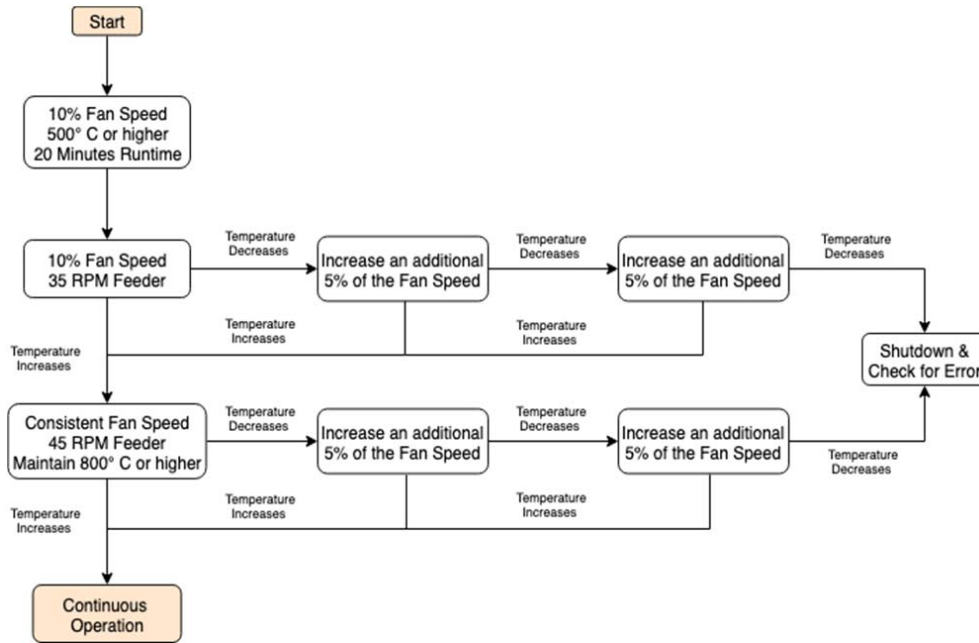

Fig. 5 Process Flowchart for the Lab-Scale Feedback Control System

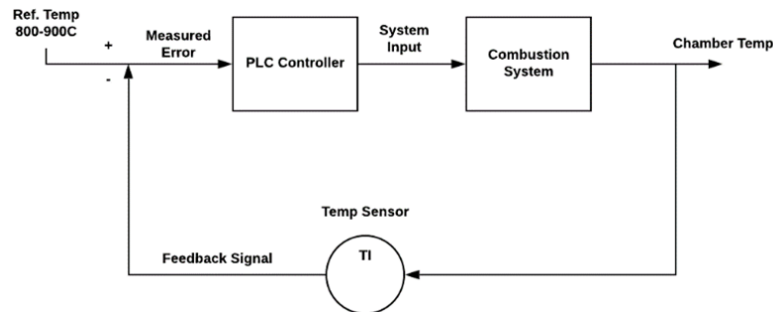

Fig. 6 PLC Controller Setup for Lab-Scale SFBC

Feedback Loop Transfer Function is expressed as:

$$E(s) = X(s) - Y(s) \tag{1}$$

$$Y(s) = G(s).E(s) \tag{2}$$

$$Y(s) = X(s). \frac{G(s)}{1+G(s)} \tag{3}$$

The feedback transfer function is expressed as shown in (3). The error signal  $E(s)$  was expressed as the difference between the system input  $X(s)$  and the system output  $Y(s)$ . This expresses the deviation from the setpoint as shown by (1). The error signal then becomes the direct input to the system

represented as  $G(s)$  resulting in the correct output  $Y(s)$  as expressed in (2). Solving for  $Y(s)$  using (1) and (2) results in (3), which is a general form of the feedback transfer function.

### III. RESULTS

The feedback control system developed using the PLC S7-1200 module was integrated into the lab-scale combustion system. With the written ladder logic program blocks, the experimental data obtained from the automated system were correlated with the data obtained from manual operations. Fig. 7 shows the correlation for the fuel feeding rate which expresses the motor speed in RPM. The correlation for air velocity from the blower expresses the amount of air being

blown into the chamber during for the combustion process is shown in Fig. 8. It was observed that the developed program blocks in PLC accurately captured the existing manual control with minimal differences.

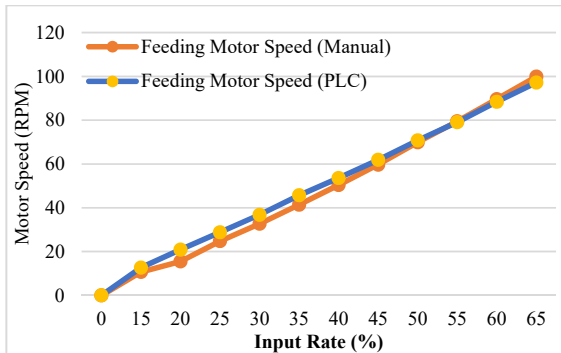

Fig. 7 Correlation of Manual with PLC Input Controls

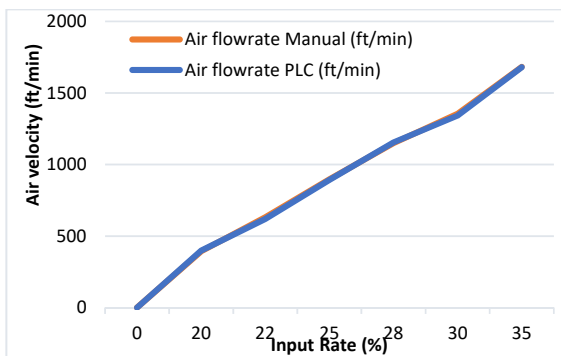

Fig. 8 Correlation of Manual with PLC Input Controls

#### A. Effect of Temperature

The temperature distribution observed from the experiment conducted was shown in Fig. 9. According to [12], fluidized bed temperature is normally kept below 980 °C for coal and below 900 °C for biomass to avoid ash fusion and consequent agglomeration with minimal emissions. For this research work, the temperature was kept at a set point of 800-900 °C. The sample readings were recorded at a 15 minutes interval during the combustion process. The chamber temperatures programmed for feedback signal were plotted as shown in Fig. 9, and the variation was observed below and above the desired temperature. The air to fuel ratio was continuously corrected by the PLC controller developed. Excess air results in lower combustion chamber temperatures which may result in more formation of CO which indicates incomplete combustion. Similarly, particulate matter (PM) in the form of PAH and soot are formed at lower temperatures. In general, NO<sub>x</sub> emissions increase with bed temperature and excess air due to the enhanced reaction rate and increased oxidant respectively [13]. This could be explained by the fact that the higher temperature increased the release of fuel-N from NH<sub>3</sub> groups and thus enhanced the formation of NO<sub>x</sub>. NO emissions increase, but N<sub>2</sub>O emissions decrease, with increasing temperature. The operating conditions for this research are

kept at air velocity of 222-273 ft/min and fuel feeding rate of 60-90 RPM to control and maintain the chamber temperature.

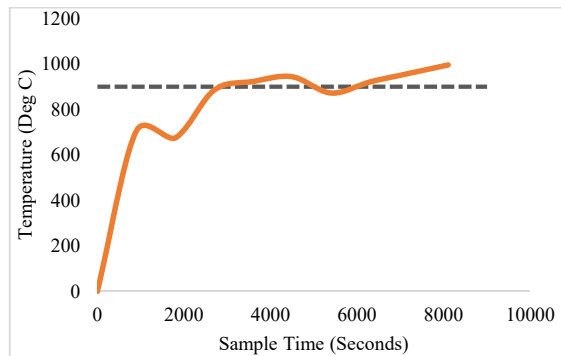

Fig. 9 Controlled Temperature Measurement

#### IV. CONCLUSION AND FUTURE WORKS

The development of a feedback control system to monitor and control the temperature distribution in the lab-scale SFBC system has been studied in this research. The temperature-based feedback control was performed using a S7-1200 PLC system which has several PIDs embedded in it. A ladder logic programming block was used in writing the programs to control air velocity and the fuel feeding rate corresponding to the measured temperature outputs. From the experiments conducted, the actual system outputs using the PLC controller agreed with the previous manual operation and helped minimize the steady-state error, thereby indicating the accuracy of the system transfer functions.

In terms of the future work, the PLC system will be used to develop an emission-based feedback control system which will be used to study and continuously monitor the emitted pollutants concentrations in the combustion chamber.

#### ACKNOWLEDGEMENT

This study has been funded by the Morgan State University (MSU) Office of Technology Transfer (OTT) and additional funding assistance from the graduate school to register for conferences. S.O Alamu would like to appreciate the contributions from the co-authors, most especially the research supervisor, Dr. S.W Lee.

#### REFERENCES

- [1] Fane, A. G., and C. Y. Wen. "Fluidized bed reactors." *Handbook of multiphase systems* (1982).
- [2] Green Jr, L. "«They're off!» in the circulating FBC handicap." *Coal mining (Chicago, Ill.)* 22, no. 11 (1985): 49-52.
- [3] McFarlane, Randall C., Terrence W. Hoffman, Paul A. Taylor, and John F. MacGregor. "Control of fluidized bed reactors. 1. Modeling, simulation, and single-loop control studies." *Industrial & Engineering Chemistry Process Design and Development* 22, no. 1 (1983): 22-31.
- [4] Singh, Ravendra, Fernando J. Muzzio, Maranthi Ierapetritou, and Rohit Ramachandran. "A combined feed-forward/feed-back control system for a QbD-based continuous tablet manufacturing process." *Processes* 3, no. 2 (2015): 339-356.
- [5] Haque, SK Hasan Hafizul, HM Imran Hassan, and SM Abul Hossain. "Comparison of Control System Using PLC & PID." In *ASEE 2014 Zone I Conference*. 2014.
- [6] Beylot, Antoine, Jacques Villeneuve, and Gaël Bellenfant. "Life cycle

- assessment of landfill biogas management: sensitivity to diffuse and combustion air emissions." *Waste management* 33, no. 2 (2013): 401-411.
- [7] Hiltunen, M., Nitrous oxide (N<sub>2</sub>O) emissions in fluidized bed boilers. Presentation in ECCP I Review: Non-CO<sub>2</sub> Gases. Brussels, Belgium. [http://forum.europa.eu.int/Public/irc/env/eccp\\_2/library?l=eccp\\_fluorinated/presentations\\_meeting](http://forum.europa.eu.int/Public/irc/env/eccp_2/library?l=eccp_fluorinated/presentations_meeting) (referred 8.2.2006).
- [8] Qian, Xuejun, Seong Lee, Raghul Chandrasekaran, Yulai Yang, Marc Caballes, Oludayo Alamu, and Guangming Chen. "Electricity Evaluation and Emission Characteristics of Poultry Litter Co-Combustion Process." *Applied Sciences* 9, no. 19 (2019): 4116.
- [9] Zhu, S., and S. W. Lee. "Co-combustion performance of poultry wastes and natural gas in the advanced Swirling Fluidized Bed Combustor (SFBC)." *Waste management* 25, no. 5 (2005): 511-518.
- [10] Griffen, Bryan T. "The design and evaluation of a PLC-based model predictive controller for application in industrial food processes." (2003).
- [11] Petruzella, Frank D. *Programmable logic controllers*. Tata McGraw-Hill Education, 2005.
- [12] Basu, Prabir. *Biomass gasification and pyrolysis: practical design and theory*. Academic press, 2010.
- [13] Li, Pin-Wei, and Chien-Song Chyang. "A comprehensive study on NOx emission and fuel nitrogen conversion of solid biomass in bubbling fluidized beds under staged combustion." *Journal of the Energy Institute* 93, no. 1 (2020): 324-334.