

# Remote Monitoring and Control System of Potentiostat Based on the Internet of Things

Liang Zhao, Guangwen Wang, Guichang Liu

**Abstract**—Constant potometer is an important component of pipeline anti-corrosion systems in the chemical industry. Based on Internet of Things (IoT) technology, Programmable Logic Controller (PLC) technology and database technology, this paper developed a set of a constant potometer remote monitoring management system. The remote monitoring and remote adjustment of the working status of the constant potometer are realized. The system has real-time data display, historical data query, alarm push management, user permission management, and supporting Web access and mobile client application (APP) access. The actual engineering project test results show the stability of the system, which can be widely used in cathodic protection systems.

**Keywords**—Internet of Things, pipe corrosion protection, potentiostat, remote monitoring.

## I. INTRODUCTION

ANTI-CORROSION of petroleum pipelines is essential for prolonging the service life of metal pipelines, ensuring energy transportation and maintaining the long-term stability and normal production of petroleum industry [1]. The problem of pipeline anti-corrosion is not only related to economic benefits, but also has great social benefits [2]. Cathodic protection technology is an electrochemical protection technology developed based on the principle of electrochemical corrosion. The potentiostat is a high-power industrial power supply which can automatically control and adjust output according to given and feedback signals and it is the core of external current cathodic protection [3], [4]. The potentiostat is widely used in buried metal pipelines and facilities in corrosive media to prevent or delay corrosion of metal pipelines and facilities and prolong their service life.

The inspectors regularly check and record the working voltage, and current and potential value of the potentiostat. Since the potentiostat is generally placed in the open field monitoring room, it brings great inconvenience to the inspection work. At the same time, the manual method cannot automatically compare the parameter changes of the potentiostat, and cannot find the potential corrosion danger in time [5]. This paper combines the IoT technology [6], [7], communication technology [8] and configuration programming technology [9] to develop a set of potentiostat remote monitoring management system, which can not only monitor

three working states and three working parameters of the potentiostat in real time, but also realize the function of a remote regulating potentiostat. It saves labor costs and improves the overall performance of the pipeline anti-corrosion protection system.

## II. SYSTEM ARCHITECTURE

### A. Potentiostat

This paper selects the KTCP-3 series high frequency switching potentiostat. The potentiostat takes IGBT as its core device and uses digital control technology and high-frequency switching power supply technology to complete power conversion. It has the advantages of small size, light weight, and with high power factor, low ripple coefficient and precise control. The main technical indicators of the potentiostat are shown in Table I.

TABLE I  
MAIN TECHNICAL PARAMETERS OF A KTCP-3 POTENTIOSTAT

Project	Parameter value
Output voltage	6-200V
Output current	5-200A
Filtering range	50Hz (60Hz)
Frequency fluctuation	47.5Hz-63Hz
DC input	24V DC power supply
AC input	Single-phase AC220V $\pm$ 20%; Three-phase AC380V $\pm$ 20%
Potential accuracy	$\pm$ 5mV
Insulation resistance	> 50 M $\Omega$

The remote control interface of the potentiostat is shown in Fig. 1, which includes a total of 16 input and output interfaces.

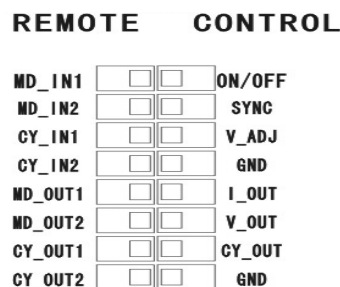

Fig. 1 Remote interface diagram of a KTCP-3 potentiostat

16 interfaces mentioned above have different definitions and undertake corresponding input and output functions. The interfaces and functions used in this design are as follows:

- (1) ON/OFF: Digital output interface, the power mainframe

Liang Zhao is with the Key Laboratory of Intelligent Control and Optimization for Industrial Equipment of Ministry of Education, School of Control Science and Engineering, Dalian University of Technology, Dalian, 116024, China (corresponding author, e-mail: zliang@dlut.edu.cn).

Guichang Liu is with the Department of Chemical Engineering, School of Chemical Engineering, Dalian University of Technology, Dalian 116024, PR China (e-mail: gchliu@chem.dlut.edu.cn).

- closes main output circuit at high level.
- (2) SYNC: Digital output interface, which is used to set whether the power mode and reference electrode can be switched. Switching is allowed at high level, and the output state signal of the power supply can only be accepted at low level.
  - (3) MD\_IN1/MD\_IN2: Digital input interface for setting power supply working mode: 1/0 is stable voltage mode; 0/1 is steady current mode; 1/1 is automatic mode; 0/0 is undefined.
  - (4) CY\_IN1/CY\_IN2: Digital input interface for setting reference electrode of potentiostat power supply: 1/0 is set as reference electrode 1; 0/1 is set as reference electrode 2; 1/1 is set as reference electrode 3; 0/0 is undefined.
  - (5) MD\_OUT1/MD\_OUT2: Digital output interface for outputting the current power supply working mode: 1/0 means working in steady-state mode; 0/1 means working in steady-state mode; 1/1 means working in automatic mode; 0/0 is undefined.
  - (6) CY\_OUT1/CY\_OUT2: Digital output interface for outputting the current power reference electrode access number: 1/0 means reference electrode 1; 0/1 means reference electrode 2; 1/1 means reference electrode 3; 0/0 is undefined.
  - (7) V\_ADJ: Analog input port, the voltage input range is 0-5V, it is used to input external voltage regulation and adjust independently in the mode of voltage stabilization, current stabilization and automation.
  - (8) I\_OUT: Analog output port, the output range is 0-5V, it is used to output the current output current value of the potentiostat.
  - (9) V\_OUT: Analog output port, the output range is 0-5V, it is used to output the current output voltage value of the potentiostat.
  - (10) CY\_OUT: Analog output port, the output range is 0-5V, it is used to output the current output potential value of the potentiostat, corresponding to the potential value of the reference electrode -2.5V to +2.5V.

### B. Monitoring System Architecture

The design of the remote monitoring system for the potentiostat in this paper is based on the architecture of the IoT. The overall structure of the system is shown in Fig. 2.

- Perception layer: The main function is to perform parameter acquisition, mode control and output adjustment of the field potentiostat. EDC8000 PLC is selected to realize acquisition and control functions. The PLC has eight digital input interfaces, eight digital output interfaces, four analog input interfaces and two analog output interfaces. It also supports three RS485 communications and can meet the needs of the system.
- Transport layer: The main function is to establish communication through the GPRS network, and provide RS485 communication interface, which can directly connect the perception layer EDC8000 to realize data transmission to remote servers.
- Application layer: The main function is to visualize the

data, responsible for the display and storage of data, and realize human-computer interaction. The configuration screen is developed on the cloud platform to display, record and remote control the potentiostatic parameters.

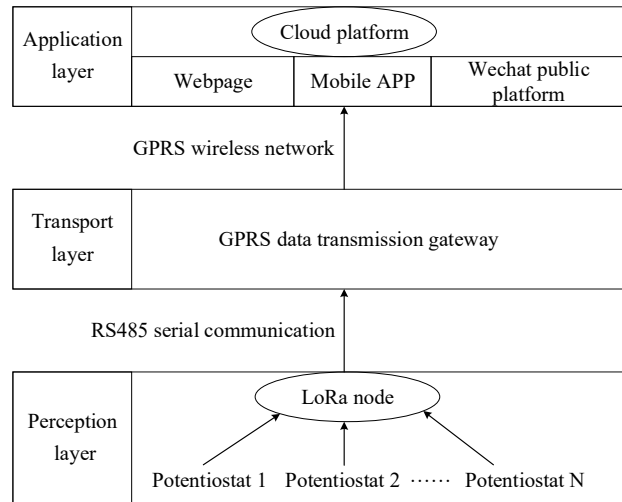

Fig. 2 System overall structure design block diagram

## III. METHODOLOGIES OF SYSTEM IMPLEMENTATION

### A. PLC Programming

The PLC program for remote monitoring of potentiostat is shown in Fig. 3, which is programmed by function block. In Fig. 3, (a) is the operation mode selection of the potentiostat, the input pins are I0.0-I0.1. Three working states are generated by decoding with three AND gate circuits, which are expressed by the internal registers V8.00-V8.02 of PLC, indicating that potentiostat operates in voltage, current and potential, respectively. In Fig. 3, (b) is the electrode working mode selection of the potentiostat, the input pins are I0.2-I0.3. Three working states are generated by decoding with three AND gate circuits, which are expressed by the internal registers V8.03-V8.05 of the PLC, indicating that the potentiostat operates in the Y1 electrode, the Y2 electrode and the Y3 electrode, respectively. In Fig. 3, (c) is the remote and local working mode selection control of the potentiostat. The output of Q0.04 is controlled by the internal register V11 of PLC, the high level corresponds to the remote mode and the low level corresponds to the local mode. In Fig. 3, (d) is the working state remote control module of the potentiostat. The PLC internal registers V9.00-V9.02 control Q0.00 and Q0.01, and realizes the switching of three working states through two OR gate circuits. The PLC internal registers V10.00-V10.02 control Q0.02 and Q0.03, and realizes switching of three working electrodes through two OR gate circuits. In Fig. 3, (e) is the analog acquisition module of potentiostat. The current mapping PLC internal register VW0, the voltage mapping PLC internal register VW2, the potential mapping PLC internal register VW4, the analog acquisition range of PLC is 0-5v, and the corresponding code value is 0-10000 yards. In Fig. 3, (f) is the

analog output control module of the potentiostat. The PLC internal register VW6 controls the voltage output, VW12 controls the current output, VW14 controls the potential output, and the output control enable signal is made through V9.00-V9.02.

*B. Cloud Configuration Program Design*

The cloud platform interface is an interactive interface, a human-computer interaction window, similar to configuration software, through which the configuration screen can be drawn. In the configuration screen, the environment data in a greenhouse can be visually displayed in the form of graphics, charts, display boxes and so on, which is convenient for people to view. On the platform, the functions of device binding, data rule establishment, configuration picture drawing and user management are realized. As long as there is a network, the greenhouse environmental data can be viewed remotely through the computer or mobile phone APP. The overall design flow of the interface design is shown in Fig. 4.

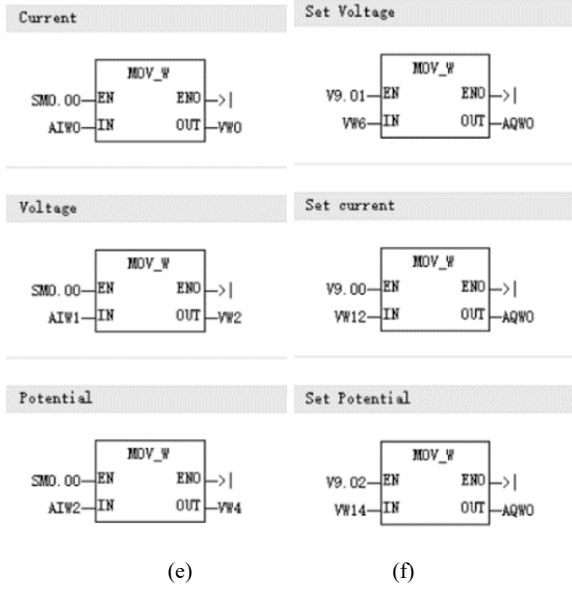
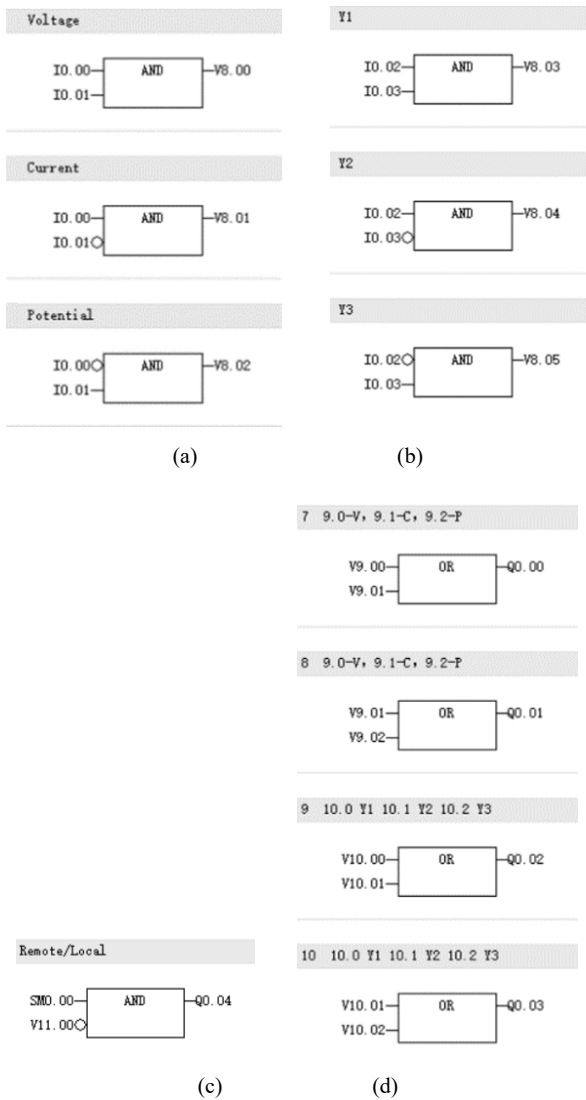

Fig. 3 PLC program for remote monitoring of potentiostat

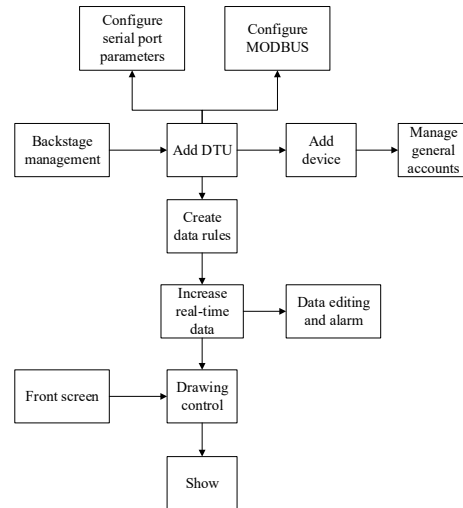

Fig. 4 Interface design flow chart

The authority management function of the potentiostat remote monitoring system can realize the three-level user authorized login management through the background database.

- (1) Administrators, with the highest authority, can access all potentiostat equipment real-time data, historical data, real-time curve, alarm value settings and other functions under the system through logging in with an administrator user name and password, and can remotely control and modify the working status of potentiostat and set value parameters.
- (2) Local administrators, with intermediate authority, can view all the parameters of potentiostat real-time data, historical data, real-time curve and alarm settings assigned by the system to a customer through logging in the user name and password, but are not able to control remotely

the system.

- (3) Ordinary users, with the lowest authority, can only access the potentiostat real-time data assigned to customers through logging in to the system, but the advanced functions such as historical data and real-time curve state cannot be consulted.

IV. SYSTEM TESTING APPLICATION AND MEASUREMENT RESULTS

The field engineering photo of the potentiostat monitoring system is shown in Fig. 5. The four potentiostats in the project are located inside a cabinet, which can be cascaded by system, with one EDC8000 device used as the main machine, and the other three used as the slave machine, which are then connected through the RS485 bus. In this way, the stability and reliability of the system are improved, and the management and upgrade of the system are facilitated. The EDC800 main machine module and power module can be seen at the bottom of Fig. 5, with the other three slave machine modules placed inside each potentiostat. During the system debugging process, developers need to check the actual voltage, current and potential values of the potentiostat panel on the spot, then compare and adjust the monitoring values with the cross-platform cloud.



Fig. 5 Potentiostatic monitoring field photos

TABLE II  
VOLTAGE STATISTICS

	Voltage			
	1#	2#	3#	4#
Maximum value	6.298	6.079	7.482	6.625
Minimum value	6.296	6.072	7.472	6.616
Average value	6.2962	6.0764	7.4756	6.6208

TABLE III  
CURRENT STATISTICS

	Current			
	1#	2#	3#	4#
Maximum value	17.566	13.089	16.401	15.476
Minimum value	11.874	8.304	6.203	10.165
Average value	16.1155	11.8381	15.0643	14.3393

TABLE IV  
POTENTIAL STATISTICS

	Potential			
	1#	2#	3#	4#
Maximum value	0.426	-0.014	-0.024	0.122
Minimum value	-0.212	-0.186	-0.061	-0.130
Average value	0.1584	-0.1155	-0.0373	0.0019

The system has been in operation since May 2017 and has been operating stably for more than 2 years. The system software work interface is shown in Fig. 6, where (a) is the computer web page login access and (b) is the mobile app access. The four potentiostats in Fig. 5 all work in constant voltage mode. Tables II-IV give the statistics of the maximum, minimum and average values of voltage, current and potential from June 20 to July 8. Figs. 7-9 show the real-time curve changes during this period. From Table II, we can see that the fluctuation range of voltage is very small, which indicates that the system is stable. From Figs. 8 and 9, we can see that the variation range of current and potential is relatively large, mainly affected by the change of load, and the working current is automatically adjusted to keep the voltage unchanged.

In addition to the basic monitoring display function, the system has developed a remote control function. By clicking the Remote button, the user can switch to the remote control mode, which can switch the working state of the potentiostat, such as changing from constant voltage position to constant current position, and support remote setting of voltage, current and potential output values. In addition, by clicking on the three function charts on the right, the user can view the historical curve, historical data and alarm information.

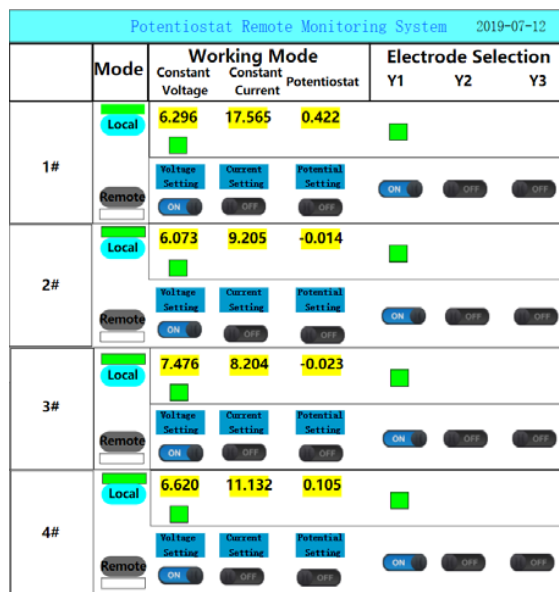

(a)

Potentiostat Remote Monitoring System						2019-07-12		
	Mode	Working Mode			Electrode Selection			
		Constant Voltage	Constant Current	Potentiostat	Y1	Y2	Y3	
1#	Local	6.296	17.565	0.422	<input checked="" type="checkbox"/>	<input type="checkbox"/>	<input type="checkbox"/>	
	Remote	<input type="text"/>	<input type="text"/>	<input type="text"/>	<input type="checkbox"/>	<input type="checkbox"/>	<input type="checkbox"/>	
2#	Local	6.073	9.205	-0.014	<input checked="" type="checkbox"/>	<input type="checkbox"/>	<input type="checkbox"/>	
	Remote	<input type="text"/>	<input type="text"/>	<input type="text"/>	<input type="checkbox"/>	<input type="checkbox"/>	<input type="checkbox"/>	
3#	Local	7.476	8.204	-0.023	<input checked="" type="checkbox"/>	<input type="checkbox"/>	<input type="checkbox"/>	
	Remote	<input type="text"/>	<input type="text"/>	<input type="text"/>	<input type="checkbox"/>	<input type="checkbox"/>	<input type="checkbox"/>	
4#	Local	6.620	11.132	0.105	<input checked="" type="checkbox"/>	<input type="checkbox"/>	<input type="checkbox"/>	
	Remote	<input type="text"/>	<input type="text"/>	<input type="text"/>	<input type="checkbox"/>	<input type="checkbox"/>	<input type="checkbox"/>	

(b)

Fig. 6 Software work interface: (a) Web access (b) Mobile APP

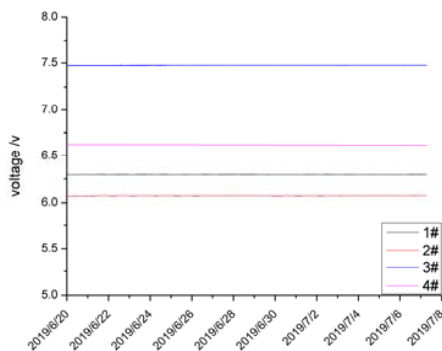

Fig. 7 Voltage real-time curve

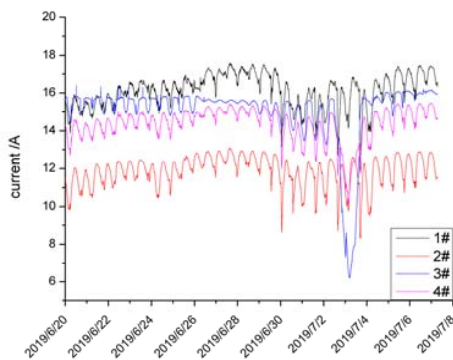

Fig. 8 Current real-time curve

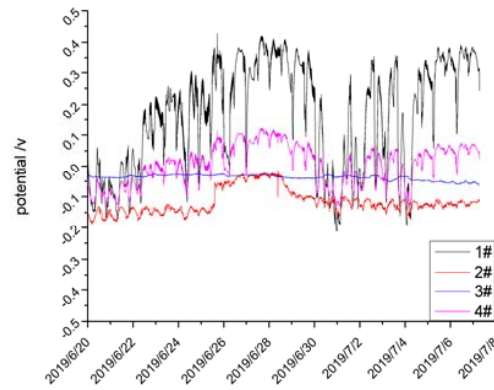

Fig. 9 Potential real-time curve

V. CONCLUSION

With the popularization and application of cathodic protection technology in the anti-corrosion engineering of buried metal pipelines, research on the pipeline anti-corrosion potentiostat and its control system has entered a period of rapid development and has become a hot topic in the petrochemical industry. This paper develops a potentiostat remote monitoring system based on the IoT technology, and its ease to set up a network. Configuration programming is used to develop a fast and efficient human-machine interface, which supports web access and mobile phone client APP access. The actual test results show that the system runs steadily and can meet the engineering requirements of a remote monitoring of potentiostat.

ACKNOWLEDGMENT

This work is supported by National Natural Science Foundation of China (61803067).

REFERENCES

- [1] Real Time Implementation of Incremental Fuzzy Logic Controller for Gas Pipeline Corrosion Control Gopalakrishnan Jayapalan, Ganga Agnihotri and D. M. Deshpande Journal: Advances in Fuzzy Systems, 2014, Volume 2014, Page 1 DOI: 10.1155/2014/203739.
- [2] M.AI Akcayolm. Application of Fuzzy Logic Controlled Cathodic Protection on Iraq-Turkey Crude Oil Pipeline (J).Applied Intelligence, 2006(23):43-50.
- [3] T.Hong, Y.H, Sun, W.P, and Jepson.Study on Corrosion Inhibitor in Large Pipelines under Multiphase Flow Using EIS (J) .Corrosion Science, 2002(44):101-112.
- [4] Hong T , Chen Y , Sun Y H , et al. Monitoring corrosion in multiphase pipelines (J). Materials & Corrosion, 2001, 52(8):590-0.
- [5] Mansfeld F . The use of electrochemical techniques for the investigation and monitoring of microbiologically influenced corrosion and its inhibition – a review (J). Materials & Corrosion, 2015, 54(7):489-502.
- [6] Civerchia F, Bocchino S, Salvadori C, et al. Industrial Internet of Things Monitoring Solution for Advanced Predictive Maintenance Applications (J). Journal of Industrial Information Integration, 2017:S2452414X16300954.
- [7] Ren L, Jiang T, Jia Z G, et al. Pipeline corrosion and leakage monitoring based on the distributed optical fiber sensing technology (J). Measurement, 2018, 122:57-65.
- [8] Pillai J A, Aaron B J. Review of information and communication technology devices for monitoring functional and cognitive decline in Alzheimer's disease clinical trials (J). Journal of Healthcare Engineering, 2015, 6(1):71-83.
- [9] Nguyen T N, Munson E V, Cheng T. Object-oriented Configuration

Management Technology can Improve Software Architectural  
Traceability(C)// Acis International Conference on Software Engineering  
Research. 2005.