

Case Study of the Roma Tomato Distribution Chain: A Dynamic Interface for an Agricultural Enterprise in Mexico

Ernesto A. Lagarda-Leyva, Manuel A. Valenzuela L., José G. Oshima C., Arnulfo A. Naranjo-Flores

Abstract—From August to December of 2016, a diagnostic and strategic planning study was carried out on the supply chain of the company Agropecuaria GABO S.A. de C.V. The final product of the study was the development of the strategic plan and a project portfolio to meet the demands of the three links in the supply chain of the Roma tomato exported annually to the United States of America. In this project, the strategic objective of ensuring the proper handling of the product was selected and one of the goals associated with this was the employment of quantitative methods to support decision making. Considering the antecedents, the objective of this case study was to develop a model to analyze the behavioral dynamics in the distribution chain, from the logistics of storage and shipment of Roma tomato in 81-case pallets (11.5 kg per case), to the two pre-cooling rooms and eventual loading onto transports, seeking to reduce the bottleneck and the associated costs by means of a dynamic interface. The methodology used was that of system dynamics, considering four phases that were adapted to the purpose of the study: 1) the conceptualization phase; 2) the formulation phase; 3) the evaluation phase; and 4) the communication phase. The main practical conclusions lead to the possibility of reducing both the bottlenecks in the cooling rooms and the costs by simulating scenarios and modifying certain policies. Furthermore, the creation of the dynamic interface between the model and the stakeholders was achieved by generating interaction with buttons and simple instructions that allow making modifications and observing diverse behaviors.

Keywords—Agrilogistics, distribution, scenarios, system dynamics.

I. INTRODUCTION

A relatively recent field of logistics, agrologistics comprises all activities in the supply chain necessary to tailor the offer of products of the field with the demand of the market of those products in local or international markets [1]. Agrologistics can be considered a sub-discipline of logistics focused on the agri-food sector. This area is made up of players responsible for production (growers and producers), processing (food products industry), and distribution (storage centers, carriers, service providers, and merchants).

Agriculture around the world has been able to respond to the growing demand for agricultural products. Although the worldwide demand for agricultural products has continued to grow, it has done so more slowly over the past few decades. Between 1969 and 1989, the annual average growth of demand was 2.4%, but dropped to only 2% in the following 10

years [2]. In addition, over the past few decades, the global productive potential of agriculture has surpassed demographic growth. This has led to a slow but constant increase in the average availability of foodstuffs per inhabitant. The availability of foodstuffs per capita worldwide has since increased, from around 2,200 kilocalories per day at the beginning of the sixties to more than 2,800 kilocalories in 2009 [2]. Furthermore, the National Agrologistics Program, published by [3], as a methodology for fulfilling the Sectorial Plan, and therefore the National Development Plan: Mexico Inclusive and Prosperous, which was developed by Wageningen, UR Food & Biobased Research in 2014, establishes five lines of work that seek to strengthen Mexico, taking advantage of the current conditions to make it one of the leading countries in the export of fruit and vegetable products. The National Agropark System can be considered to be the part of the National Agrologistics Program that focuses on the process of constructing agroparks or other agrologistic assets related to the postharvest. The System anticipates resources to prepare diagnostics and executive projects, and also supplements investment for the development of agroparks, and the investment in equipment for the companies and entrepreneurs in the agroparks [4], [5].

The five lines of work are: 1) A public policy framework with a comprehensive vision that coordinates the actions of relevant dependencies to an integrated territorial development, synergetic investment programs, and the efficient use of resources; 2) a regulatory framework prioritizes quality and ensures fulfillment of sanitary conditions, 3) the infrastructure necessary to facilitate the production, transformation, transport, and distribution of agri-food products; 4) business models that are attractive to all players in the business, making investment viable; and, 5) a cycle of innovation based on training and knowledge generation. Thus, over the last decade, crop production in the Central America region has grown more rapidly than the worldwide average. Mexico is the greatest producer of vegetables in the region, followed by Brazil. These two countries are the tenth and the twelfth producers worldwide of vegetables, respectively. Between the years 2000 and 2011, Brazil had the highest annual growth rate in South America (4.4%), mainly due to increased yields (3.0% annually), since there was relatively little expansion of the cultivated surface [6].

In Mexico, the habits of vegetable consumers are diverse and are influenced by purchasing power and local traditions. In the past few years, vegetable consumption has increased,

Ernesto Lagarda is with the Sonora Institute of Technology, Mexico (e-mail: ernesto.lagarda@itson.edu.mx).

with an annual average growth rate of 1.92% between 1980 and 2008, which demonstrates that the importance of consuming these types of crops has increased in Mexico. In spite of this, Mexico only consumes 66.63 kilos of vegetables per inhabitant per year, while in the United States, the number is 112.49 [7].

Vegetable production is one of the most profitable agricultural activities, since the agricultural surface in Mexico corresponds to 21,710 million hectares, of which, vegetables occupy 3.8% of the national surface and contribute 21% of the total production value (2000-2008). The above values reflect the importance that vegetables have in the national economy. The production value of vegetables in Mexico has seen dynamic growth, from 1980 to 2007; in nominal terms, it has increased at a rate of 30.35%. However, at 2003 prices, this value grew by 2.77% [8].

Vegetables in Mexico are produced due to the soil and the climate favoring the development of these crops, above all in the northeast of the country and in the autumn-winter cycle, when the American field presents adverse climatic conditions, bringing about a high demand for Mexican vegetables. Mexico is one of the main producers and exporters of vegetables in the world. In addition, the production of Mexican vegetables is one of the few activities to maintain a positive commercial balance within the rural sector, since the volume of vegetables exported was 4.5 times greater than that imported from 1961 to 2008, because of its comparative advantages, above all the climate in relation to other countries. In addition, the horticultural sector is considered to provide direct and indirect employment to more than a million workers on a national level, representing 20% of the population economically active in agriculture [7], [9], [10].

In Sonora, people working in the field have learned how to treat the land and understand the climate to generate foodstuffs and raw materials. In Sonora, this task is achieved through great effort as in each year agriculture perennial crops are planted. Understanding the evolution of agriculture in Sonora demands knowing past and current its characteristics to try to forecast its future tendencies [11].

With an agriculture fundamentally based on irrigation and mainly executed in the Autumn-Winter cycle, Sonora harvested 7 million tons in 2014, a quantity 2.2% less than that of previous agriculture year, with a value of 27 billion 337 million pesos. From an economic point of view, the entity stands out in the production of vegetables and grains, contributing four and two of each 10 pesos of the value of its production, respectively; likewise, it is important to consider that this agriculture encompasses diverse crops appreciated in the domestic and international markets [11].

Continuing with information from the SIAP, it is worth noting that planting and harvest occur at different cycle times. Understanding the logic of seasonality and of the agricultural cycles allows understanding the behavior of the prices and of the exchange of merchandise in and out of the country. The cycles are the following: autumn-winter: planting (October-March), harvest (December-August); Spring-Summer: planting (March-September), harvest (April-February);

perennial cycle: harvest (January-December).

TABLE I
MAIN VEGETABLES PRODUCED IN SONORA

Crop	Surface harvested	Production	Yield	Value
	(ha)	ton	ton/ha	MoP
Asparagus	9,403	81,004	8.62	2,535
Potato	13,249	412,065	31.10	2,397
Melon	3,193	106,684	33.41	626
Zucchini	5,178	100,552	19.42	547
Squash	6,212	110,303	17.76	497
Green chili	3,177	83,446	26.27	471
Watermelon	7,198	250,250	34.77	469
Tomato	1,388	82,324	59.30	354
Cucumber	727	65,146	89.63	303
Onion	1,845	37,060	20.09	252

Notes: Asparagus is the product of greatest value in millions of pesos, with 2,535, but it has the lowest yield with 8.62 ton/ha; potato uses the most surface for planting, with 13,249 ha; the lowest yield in tons per each hectare planted is squash, with 17.76%. Source: Prepared by the authors with information from [12].

According to estimates from the Agrifood and Fisheries Information Service (2015) [13], Cajeme is the municipality with the most surface planted in Sonora with 108,478 ha, followed by Hermosillo with 63,860 ha, and Navojoa in third place, with 59,579 ha.

Although the contribution of Sonoran products to the domestic market is considerable, the agriculture carried out in the state of Sonora has a high exportation orientation. Nearly two thirds of the value of the production, mainly fruits and vegetables, is sold in external market in the United States, Japan, and the European Union. One of the companies in charge of importing and exporting in the southern region of Sonora is Agropecuaria GABO S.A. de C.V. It is located in Ciudad Obregón Sonora, Mexico, with its production sector as well as its packaging in the agricultural lands of the Yaqui Valley.

Tomato production in Sonora is central to vegetable farming in Mexico. In only five years (2010-2015) the economic revenue from tomato crops has nearly tripled, as shown in Table II.

The year 2015, saw the highest production in comparison with the previous five years with a total of 136,045 tons and considering an average of 92,077; therefore, the production value was greater, having reached 806,918 pesos. The data is shown in Table III.

The subcycle where the greatest economic revenue was generated during tomato cultivation was in Autumn-Winter of 2014-2015, producing 105,483 tons of tomato, where around 540,166 pesos were earned, contributing to a little more than two-thirds of the total income. In the second subcycle, 30,562 tons of tomatoes were produced, generating earnings of 266,752 pesos.

For the 2016/2017 agricultural cycle, the State Committee of Plant Health of Sonora (CESAVE) has granted planting permits for a surface of 589 hectares, of which 352 hectares are for the Yaqui Valley, 228 hectares are for Guaymas and 9 hectares are for Caborca; the company under study

corresponds to District 148 Cajeme.

TABLE II
TOMATO PRODUCTION (2010-2015) [13]

Year	Surface planted (has)	Surface harvested (has)	Production (ton.)	Yield Ton/ha	Production value (thousands of pesos)
2010	1,732	1,708	60,131	35.20	374,019
2011	1,680	1,157	60,718	52.01	336,604
2012	1,449	1,388	82,324	59.31	353,992
2013	1,335	1,530	91,856	60.03	512,712
2014	1,549	1,540	121,387	78.82	624,807
2015	1,521	1,485	136,045	91.61	806,918
Average	1,544	1,468	92,077		

Note: The greatest earnings were generated in 2015, with 806,918 thousand pesos in production. In addition, from 2010 to 2015, 92,077 tons of tomatos were cultivated on average.

TABLE III
PRODUCTION DATA IN THE AUTUMN-WINTER (A.W.) AND SPRING-SUMMER (S.S.) CYCLES FOR 2014-2015 [13]

Sub cycle	Surface planted (ha)	Surface harvested (ha)	Production (ton)	Yield (ton/ha)	Production value (thousands of pesos)
A.W.14/15	1,222	1,186	105,483	89.0	540,166
S.S.15/15	299	299	30,562	102.1	266,752
Total	1,521	1,485	136,045		806,918

Notes: The surface planted in the first Autumn-Winter subcycle (1,222 ha) was greater than that of the second Spring-Summer subcycle (299 ha), However, the yield was greater in the second subcycle (102.1 ton/ha) compared with that of the first subcycle (89.0 ton/ha).

TABLE IV
DISTRIBUTION OF THE PLANTED SURFACE IN THE RURAL DEVELOPMENT DISTRICTS FOR 2015 [13]

DDR	Surface planted (has.)	%
140 Magdalena	55	3.6
141 Agua Prieta	5	0.3
142 Ures	1	0.1
144 Hermosillo	69	4.5
147 Guaymas	291	19.1
148 Cajeme	969	63.6
149 Navojoa	131	8.6
Total	1,521	100

Note: Cajeme has 969 hectares planted and 64 percent of the total planted surface; Guaymas has 291 hectares planted, a third of that of Cajeme, followed by Navojoa, with 131 hectares planted.

Tomato is produced in the seven Districts. Cajeme has the largest sown area, with 969 hectares, which is equivalent to 63.6% of the total planted, placing this municipality as the greatest participant in tomato production in Sonora.

The company under study is Agropecuaria GABO. Previously considered a new field, it began operations in 1986 with the production of different varieties of chili. Over the years, it has incorporated new products such as the potato it currently produces, with deliveries to Sabritas (the Frito-Lay Corporation's denomination in Latin America) a company dedicated to the fabrication and marketing of fried foods based on potato, tomato, and pomegranate, an innovative product in the valley, to continue with the growth of same. The organization has the following philosophy that sets its course: Vision: "To be a leading company in agricultural production with quality, competitiveness, and profitability". Its mission

establishes: "We are a family company dedicated to the production and marketing of high quality agricultural products for the well-being of the end consumer". The values are: adaptability to changes in the environment, commitment to quality in our work, and the profitability of the company, ethics, respect, and perseverance with the established objectives. GABO has the following positions and levels in the company, as seen in Fig. 1, which shows the organigram, composed of 12 positions.

Agropecuaria GABO is a company with goals of growth, experiencing and analyzing possible changes and introduction to new products, seeking to innovate and transcend within the agricultural market. The products cultivated in this company have varied according to the opportunities in the market, and they currently have the following: Cucumber (Persian), Tomato (Roma), Potato (Frito Lay, Atlantic, and Fianna), Chile (jalapeño bravo), Asparagus (green), Bean (azufrado higuera), and Pomegranate (wonderful).

The company distributes through a wholesaler (Chucho produce), which is in charge of marketing GABO's products. The company wants to enter the pomegranate export market to open itself to new markets and have another product in its catalog. Agropecuaria GABO is part of a partnership composed of: El Comparto (production of *azufrado* bean and *Fianna* potato), PRODESPA (asparagus production and humus production by means of vermiculture), Agropecuaria GABO A en P (pomegranate production) and GABO S.A. de C.V. Seen graphically, the supply chain of the company can be represented in the map presented in Fig. 2.

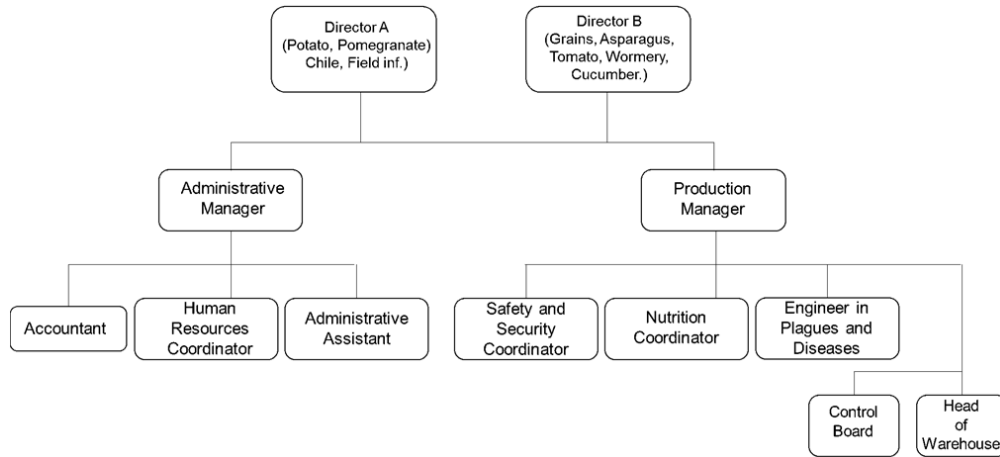

Fig. 1 Organigram for Agropecuaria GABO

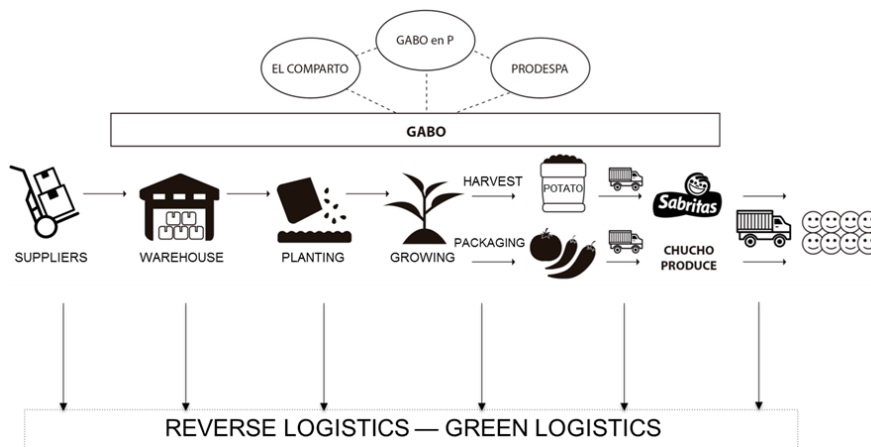

Fig. 2 Supply chain for Agropecuaria GABO S.A. de C.V.

II. PROBLEM STATEMENT

In September of 2016, a strategic planning exercise was begun in the supply chain of the company under study by two students of Masters in Supply Chain Management, which developed into the following strategic objectives and projects of greater priority. The objectives were formulated based on the proposal of [14], using the Organizational Elements Model (OEM) in its corresponding indicator: mega, macro, micro, processes, and resources. Fig. 3 shows the cause-effect relationships in the strategic objectives.

One of the goals associated with the strategic objective: *ensure proper handling of the product*, found in the *Micro (production)* perspective, established the development of a quantitative model to support management’s decision making, presenting the challenge of establishing a procedure based on formal technological and short-term solutions translated into the development of models for each link of the supply chain of the company’s seasonal product, for them to be easily operated by the users through the creation of a practical and simple to operate dynamic interface. In this sense, the focus of this case study is centered on the distribution link. However, another two case studies deal with the supply link and

production link, as well as that of reverse logistics. Fig. 3 shows the export distribution route that the (Roma) tomato product follows from the company’s location to the border with Nogales, Arizona.

The route that the transporter takes from the company Agropecuaria to the wholesaler Chucho Produce is presented in Fig. 3, covering Guaymas, the checkpoint in Querobabi, and its eventual arrival to Customs on the border with the United States, where the product is distributed.

The completion of this project derives from the Strategic Planning previously carried out by the postgraduate students. Among the plans developed in this project was the creation of scenarios in each link of the supply chain.

To more clearly illustrate the distribution process, a mapping of same is presented in Fig. 5, where it is delimited, since the packaging is done with pallets (it is worth noting that each pallet contains 81 cases of Roma tomato), until the product is offloaded and delivered to the customer or wholesaler for its sale.

The pallets of tomato are transferred from packaging to the pre-cooling area by forklift. The pre-cooling area has two rooms, one with a 16-pallet capacity and the other for eight

pallets. In total, 69 pallets fit in the pre-cooling area, taking into account those that remain in waiting.

Tomatoes placed in the pre-cooling room should reach an approximate temperature of 45 - 50 degrees Fahrenheit in a

period of 3 to 6 hours, depending on the initial temperature. When the tomato reaches the optimal temperature, it is removed from the pre-cooling room and left in waiting in the same room to later be shipped.

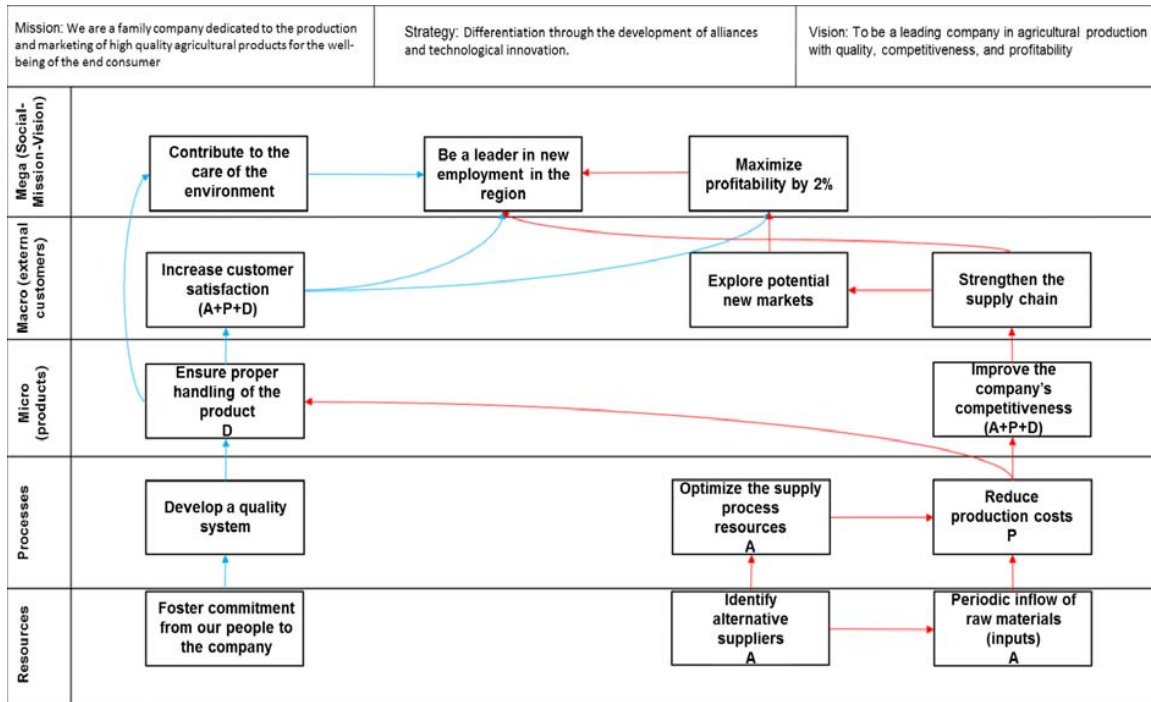

Fig. 3 Strategic map. Source: Prepared by authors, with data of [15]

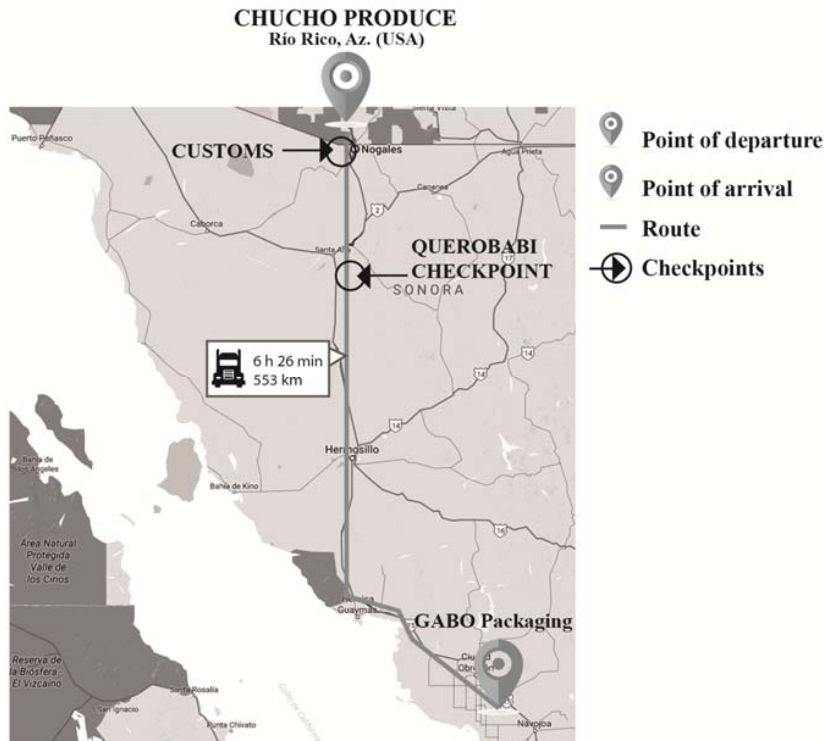

Fig. 4 Export route of the company Agropecuaria. Source: Prepared by the authors, with data of Google Maps (2017)

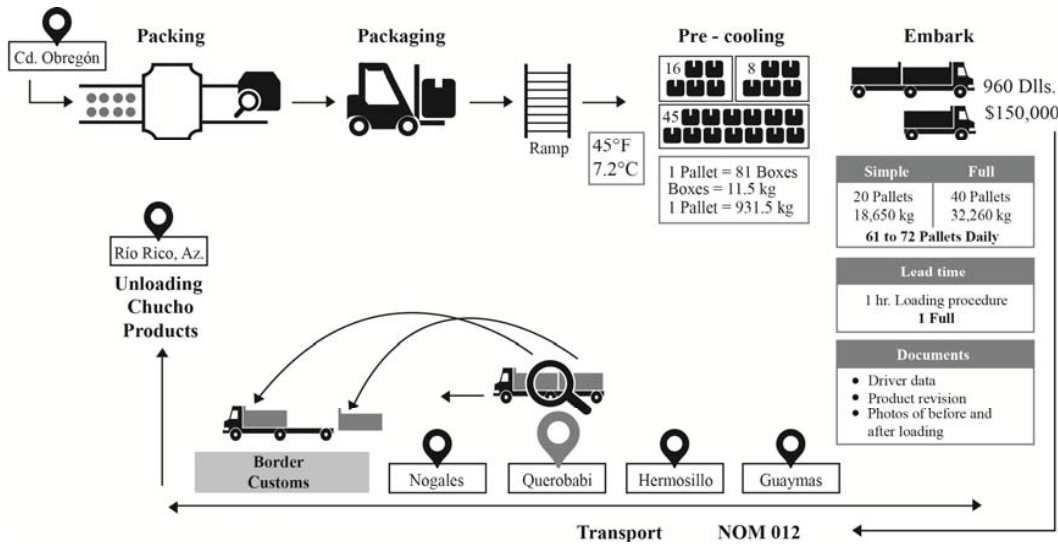

Fig. 5 Mapping of the distribution process. Source: Prepared by the authors with data from [16]

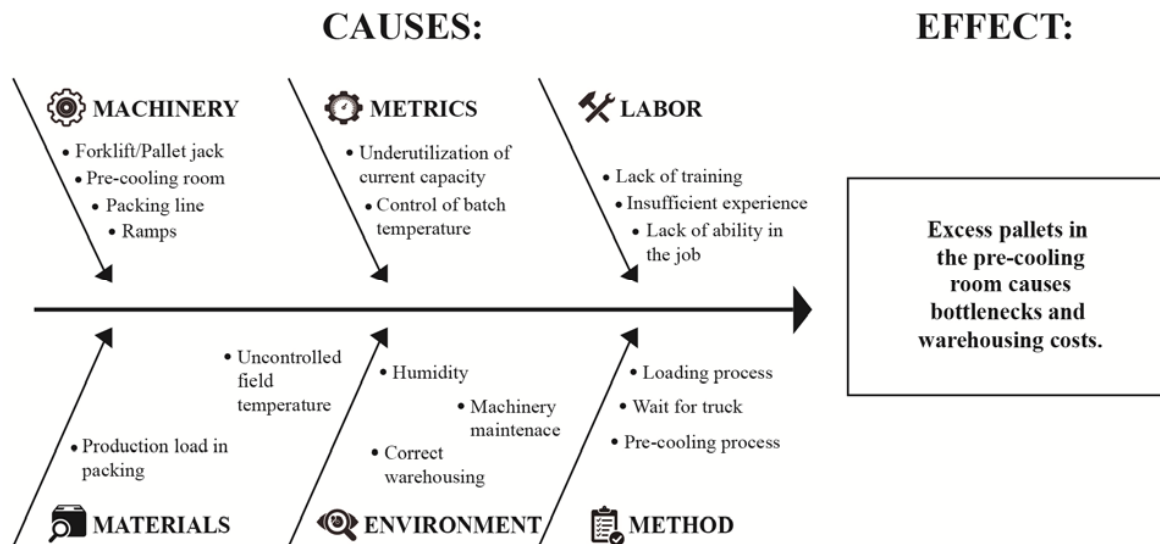

Fig. 6 Cause-Effect Diagram

In the shipment process, the pallets are loaded onto the truck for distribution. The modalities in which they can be transported are in a simple case (20 pallets/case) or a full case (40 pallets/case), depending on the number of existing pallets. After loading the truck, the product is transported to the wholesaler in Nogales, Arizona, USA, who takes care of marketing the product to different places.

From observations of the installations and of the distribution process of the company under study, the following analysis, presented in Fig. 6, was carried out, where through a cause-effect diagram, some variables are presented that influence the process and the effect it causes, which was an important element for understanding the current problem of the organization in the distribution chain.

According to the representation of the cause-effect diagram, the causes given were in the machinery, metrics, labor,

materials, environment, and method. In each of these, the factors that affected the distribution process are identified, and have a critical influence when shipping.

In seasons of high demand, when the tomato harvest is carried out at its maximum capacity (5,000 tares of tomato daily), is where the problem under study is presented. Product output can reach 74 pallets daily, surpassing the capacity of the pre-cooling room, which is 69 pallets. This means that not all the product reaches the optimal temperature, due to the policies of the company demanding that the product be distributed. In addition, high quantities of product remain outside the pre-cooling room at high temperatures, which can cause the top-quality product (Green Tomato) to become second quality product (Pink Tomato) causing losses, since the case of top quality tomato is priced at \$8.30 dollars and the second quality varies between \$4.00 and \$5.00 dollars per

pound, and when the product loses quality, it causes a reduction in income for the organization.

From the above, it was detected that there is no balance point in the utilization of the cooling room's capacity during the storage of pallets of Roma tomato and the shipping process, of which, affects decision making in the sales process, consequently affecting income.

From the above, the problem was posed as the following challenge: *What model parameters allow observing the reduction of bottlenecks in the Roma tomato distribution processes through the simulation dynamic in a way that does not affect the quality and costs of the Roma tomato?*

Objective. Develop a model that allows determining the most appropriate parameters to decrease the bottlenecks without affecting the quality of the Top Roma tomato for its export to international markets through simulation of the storage and distribution processes.

III. THEORETICAL FOUNDATION

The supply chain is the integration of the main functions of the business from the end user through the original suppliers who offer products, services, and information that add value to the customers and other interested parties (stakeholders); it is the group of functions, processes, and activities that allow the raw materials, products or services to be transformed, delivered, and consumed by the end customer, where the evaluation of its key performance indicators must be periodically reviewed [17]-[21]. From this, the supply chain can be considered that which integrates three main associated links: those of supply, of production, and of distribution, and includes the concepts of reverse logistics and green logistics to achieve the definition of a sustainable supply chain.

It is worth noting that in this framework, logistics is the part of the supply chain process that plans, carries out, and efficiently and effectively controls the stream and storage of the goods and services, as well as the related information from the point of origin to the point of consumption, with the purpose of satisfying the customer's requirements; it also includes, from a sustainable perspective, the direct and reverse stream of goods and services and all information related to these. It is possible to see logistics as that which takes care of joining production and marketing through techniques and strategies. Logistics is the art of planning and coordinating all activities and processes necessary for generating a product or service and delivering it to the point where and when the end customer requires it, optimizing the cost [22]-[26]

According to [27], the supply of materials is the first process or component of business logistics, composed mainly of three basic elements: external suppliers, who provide the goods or services; the purchasing department who is in charge of carrying out the acquisitions associated with the demands of the organization; and the warehouse area. Furthermore, the production line includes all the activities necessary to move inputs or information through and from the production plant, for its transformation through processes for its packaging or delivery to its immediate customer, which can be to the same organization or to external customers [28]. Finally, the last

link in the supply chain is the distribution channel, which is the group of independent organizations that participate and facilitate the transference of the property during the process of making a product or service available to the end customer, to an industrial user, or to the consumer [29]-[31].

Taking into account that administration of the supply chain resorts to quantitative methods to be able to measure its performance, it is established that the following authors describe, in accordance with the proposal of this article, the theories that underpin the methodological proposal.

Systemic thought allows having the conceptual framework of these interactions and are reflected in different dynamic archetypes which allow greater clarity and understanding of each part of the supply chain from a conceptual and quantitative perspective through differential equations that are represented in diagrams that explain the streams, levels (warehouses, queues, ovens, and belts), auxiliary variables, and endogenous and exogenous parameters, which are represented in dynamic models [26], [32]-[38]. The empirical studies, such as those proposals that have been reviewed and which are consistent with this investigation, show applications and the use of models and simulations with system dynamics to support the decision-making process, allowed expanding the vision for the construction of the final proposal. Likewise, the proposals of empirical studies were reviewed to lay the foundation for the different methodologies [25], [39], [40].

IV. METHOD

The purpose of the study was the distribution link of the Roma tomato product supply chain of an agricultural company. The procedure followed was in four stages is described below and takes as a base the strategic plan of the supply chain developed from September to December of 2016.

A. Procedure

The steps for achieving the proposed objective are presented below. While several authors were considered, the methodology is based mainly on the proposal of [36], [41], [42]. The procedure is explained in four phases: 1) the conceptualization phase; 2) the formulation phase; 3) the evaluation phase, and; 4) the communication phase.

B. The Conceptualization Phase

Research was carried out on empirical studies associated with the processes of agricultural product storage and distribution related to the purpose of the study. With the help of information from bibliographic sources (state of the art), the variables, parameters, and other indicators of the distribution chain were detected. With this information, the causal diagram was developed, which explains step by step the dynamic of the models, creating behaviors with positive and negative influences.

C. The Formulation Phase

The Forrester diagram was developed based on the previously developed causal diagram, and using the software Stella Architect[®], and the equations of the model representing

the operating logic of the tomato storage and distribution link were developed from the structure.

D. The Evaluation Phase

In this step, the initial simulation model of the link under study was carried out. In this simulation, the parameters and variables were taken into account to later calibrate the model, seeking to make it as realistic as possible. After building the Forrester diagram and applying the simulation model, three scenarios were developed, which are presented as: 1) the normal scenario (current), which is expected to be the closest to reality and which generates more feasible results; 2) the optimistic scenario, which is configured in such a way so as to improve the conditions of the normal scenario; and finally, 3) the pessimistic scenario, in which the most unfavorable conditions are built to worsen the normal scenario.

After creating the scenarios above, the simulation of same was carried out for later analysis on the system to detect possible changes to the variables over time, obtaining useful information for decision making. The scenarios respond with important information for the person who makes decisions in the organization.

Validation of the scenarios was carried out from the normal scenario (current) and compared with the real situation of the organization. The values that the model delivers are practically the same as what happens in reality. This allowed ensuring that the model predicts with a certainty such that it is possible from this to perform analyses of the pessimistic and optimistic scenarios.

E. The Communication Phase

To finalize the methodology stages, the user interface was developed with the Stella Architect software, through which the user will be able to interact with the simulation model and make the necessary modifications to the variables to generate information from their perspective, and allow the model to be useful to interested parties for decision making. Considering the value of this real experience and as a case study, the company and the university, under a specific agreement signed at the beginning, communicated their knowledge so that the results could be disclosed in diverse media.

V. RESULTS

A. The Conceptualization Phase

The main results associated with this phase are presented below.

1. State of the Art

The main empirical studies are presented, which are referenced to associate the most commonly recurring variables in these studies as a basis for the development of the causal model.

Table IV presents eight empirical studies applied in diverse parts of the world as a summary, considering the name of the article, the place where it was developed, the authors, and the journal in which the article was published.

TABLE IV
EMPIRICAL STUDIES OF SYSTEM DYNAMICS APPLICATIONS IN THE AGRI-FOOD SECTOR

Title of the article	Authors and Country	Journal
1. <i>Modeling of the logistics system of the potato production chain using system dynamics.</i>	[43] Colombia	AVANCES Investigación en Ingeniería Vol. 11 - No. 2 (2014) ISSN: 1794-4953
2. An Integrated Operational Research and System Dynamics Approach for Planning Decisions in Container Terminals	[44] Egypt	International Journal of Mechanical, Aerospace, Industrial, Mechatronic and Manufacturing Engineering Vol:7, No:10, 2013 System Dynamics Review Volume 18, Issue 3 Autumn (Fall) 2002 Pages 381-401
3. Transforming an agricultural trade organization: a system-dynamics-based intervention	[45] Switzerland	XIV Encuentro Colombiano de Dinámica de Sistemas, Universidad Pontificia Bolivariana Medellín - 7, 8 9 September 2016
4. Using Scenarios: A Case Study of a Corporate of Chemical Distribution Business in Mexico	[46] Mexico	Agribusinesses an International Journal, 2015, Online ISSN: 1520-6297
5. Price Transmission, International Trade, and Asymmetric Relationships in the Dutch Agri-Food Chain	[47] Netherlands	

2. Causal Diagram

Fig. 7 shows the causal diagram of the storage process in the company under study. The process begins with the input of the tomato to the warehouse, which is influenced by a production rate of 92% for top quality tomato and 8% for second quality tomato. In addition, the costs of keeping the pallets in the warehouse and the costs of inventory were identified.

The previously developed causal diagram was used to create the assumptions; these assumptions allow specifying several results with respect to the system under study.

The following hypotheses under which the dynamic of the

model is explained are three:

1. How would increasing capacity of the pre-coolings affect the bottleneck?
2. What would happen if the tomato field temperature were reduced before warehouse entrance?
3. How would reducing waiting times in the warehouse affect costs?

The main variables considered for the development of the causal diagram are measured by: quantity of pallets of tomato sent from one area to another; the waiting time in hours, minutes, and seconds of the activities and areas; and tomato pallet capacities, in areas as well as on transport trucks.

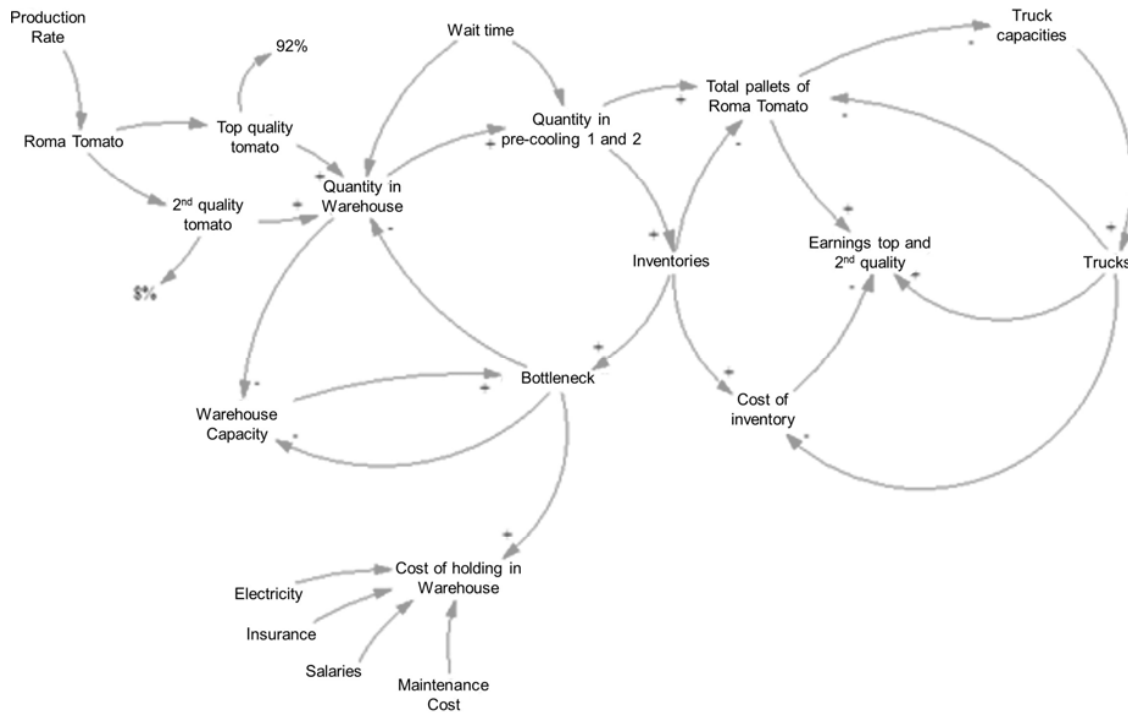

Fig. 7 Causal Diagram of Roma (saladette), Tomato Storage process of the organization under study

When analyzing the indicators of the variables and how one affects the other, for example, the production area sends pallets of tomato at regular intervals, be they top or second quality, considering that the more finished product that production sends, the greater the quantity of product in the pre-cooling room and in the warehouse. When there is more in the warehouse, there is more product in waiting or in queue to enter the pre-cooling area, but with a greater quantity in the warehouse, there will be more transported to the pre-cooling area, and consequently, a greater quantity in this area and less in the warehouse, with the product taken from this area to supply the other. This shows the first closed loop which is composed of some exogenous variables, such as the waiting times in the pre-cooling area as well as in the warehouse.

Another loop in the causal diagram explains that the greater the quantity of product in the pre-cooling area, the greater the quantity transported to loading and the greater the quantity of loaded product, and consequently, the lesser the quantity of product in pre-cooling; here, the loop is closed. Considering other variables, it is understood that having more product loaded means fewer transport trucks, be they simple or full, and having less transport of the product, means that the product is in delivery or marketing stage and being in transport means fewer losses, as the product is not stalled. With the product in this stage, there is less product in the warehouse, which closes the dynamic cycle.

To analyze this from a negative perspective, for example in the last loop: less loaded product would mean that there is less transport of pallets of tomato due to the waiting time for the product to come out of the pre-cooling room. Waiting for the

product for a determined time can change its color from yellow to green or to red, which indicates a more advanced ripening of the product, considered as a loss, since when the product arrives to the United States, its lifetime is shorter and it is therefore considered second quality; the payment for the product is now US\$5, compared with that for top quality, at \$8.3.

B. The Formulation Phase

The main results associated with this phase are presented below.

1. Forrester Diagram

The development of the Forrester diagram was based on the causal diagram, which was developed previously, but with some necessary variables, parameters, and indicators added to the diagram to correctly formulate the equations.

The process under study is limited by nature, so only an archetype was built which shows the storage process within the distribution chain, from the pallets of top and second quality tomato to their transfer to the warehouse, to the product's later introduction to the pre-cooling rooms inside the warehouse, as seen in Fig. 8.

Inside the pre-cooling room, the temperature of the tomatoes is reduced so that they will be in good condition at the point of sale. After controlling the temperature, the tomato is prepared to be transferred and remains inside the warehouse. After that, the product in queue is loaded onto the full and simple trucks, to later be transported to the seller, where the scope of the distribution link ends.

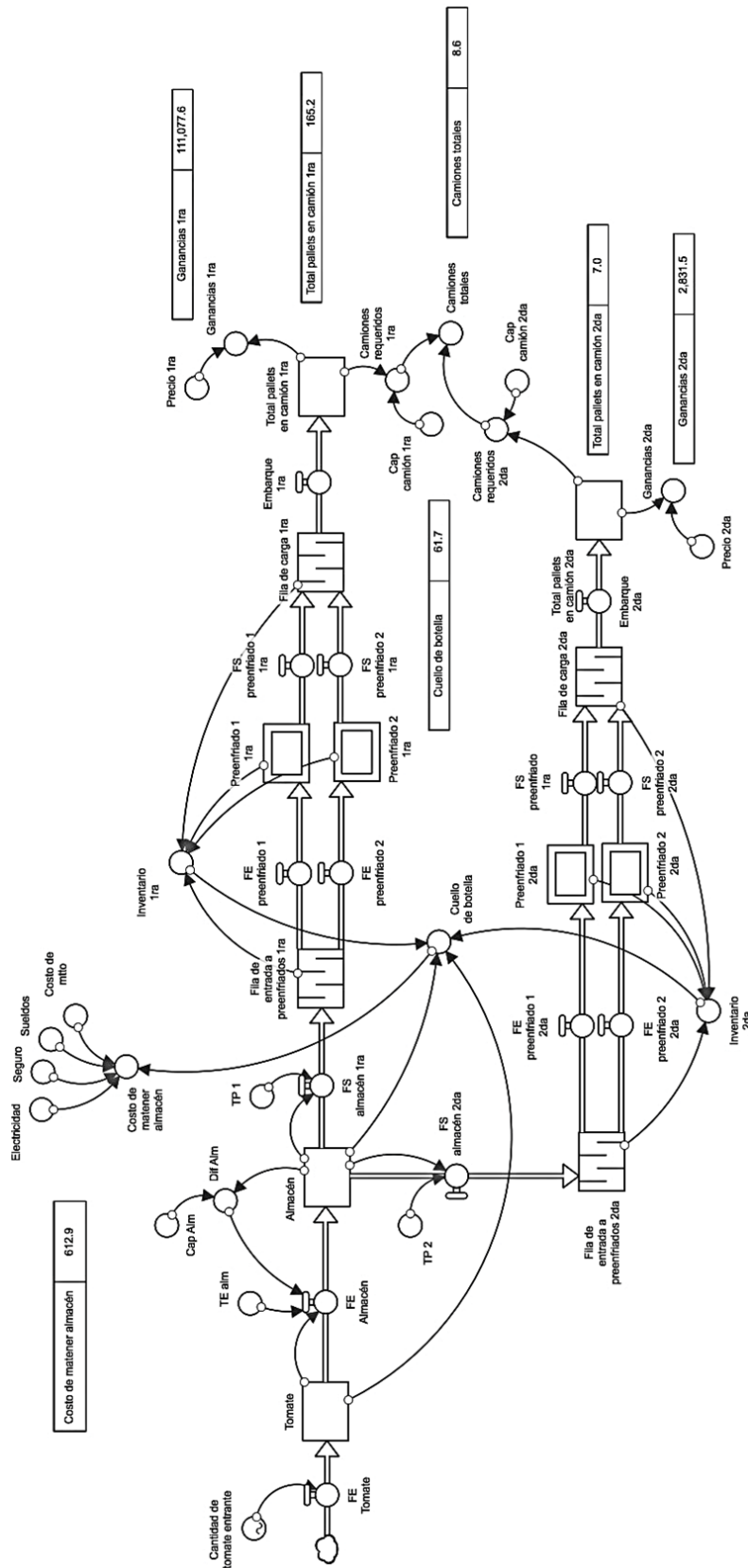

Fig. 8 Forrester Diagram

The Forrester diagram of the Roma tomato storage process in the distribution chain of the organization under study was developed using the Stella Architect software. The process works with the stock of top quality and second quality tomato product. From these levels, the product is separated into streams, moving the product over time to the warehouse.

From the warehouse, the product is moved to the queue to wait, and pallet by pallet the product moves through the stream to enter pre-cooling room 1 and pre-cooling room 2 (these are considered to be ovens, since the product must remain a certain time inside them) to control the temperature.

After pre-cooling room 1 and pre-cooling room 2, the product moves through the output streams to enter the loading queue, and from this queue to the loading area called "total trucks", where the product is loaded onto the full or simple trucks.

Two variables were introduced: the cost of keeping the products in the warehouse and the trucks required. The cost of keeping the products in the warehouse implies everything that is generated by having product inventory inside the warehouse and the pre-cooling rooms, such as: electricity, insurance, salaries, and maintenance costs.

The trucks required variable has the function of indicating the number of trucks required every day with respect to the daily quantity of outgoing product. Its purpose is to estimate how many trucks were needed for the product not to generate inventory and manage the outputs on time.

2. Mathematical Equations

The equations generated in this model are represented by type. There are level equations that represent a stock, a conveyor, or an oven. There are input and output stream variables, as well as the auxiliary variables. In this article, the most relevant equations are presented.

i. Level Equations

$A(t) = A(0) + \int_0^t [(FEA(t) - (FSAPc(t) + FSAsc(t))] dt$ (1)
where: $A(t)$ = Quantity in pallets of Roma tomato in warehouse. $A(t)$ = Input stream of pallets to warehouse. $FSAPc(t)$ = Output stream of pallets of top quality tomato to warehouse. $FSAsc(t)$ = Output stream of pallets of second quality tomato to warehouse.

ii. Input and Output Stream Equations

$$FSAsseg(t) = A(t) * TP2 \quad (2)$$

where: $FSAsseg$ = Output stream of pallets of second quality tomato to warehouse. $A(t)$ = Quantity of second quality tomato in warehouse. $TP2$ = Production rate of second quality tomato

$$FEA(t) = [TD(t) - DifA]/TEA \quad (3)$$

where: $FEA(t)$ = Input stream of pallets into warehouse. $TD(t)$ = Tomato available, $DifA$ = Difference in warehouse, TEA = Delivery time to warehouse

iii. Auxiliary Equations

$$CMA(t) = [\sum_0^6 (E + Seg + Sue + CM)] * CB(t) \quad (4)$$

where: $CMA(t)$ = Cost of keeping the pallets of tomato in inventory, E = Cost of electricity, Seg = Cost of insurance, Sue = Salaries paid to the workers, CM = Costs of maintenance, $CB(t)$ = Bottleneck.

C. Evaluation Phase

The main results associated with this phase are presented below.

1. Simulation and Construction of Scenarios

For the evaluation of the simulation model three scenarios were built: the normal scenario (current), the optimistic scenario, and the pessimistic scenario. In each of the scenarios the most critical variables were modified to observe the variations in the functioning of the model and obtain results for each scenario to compare them under the policy change established by the interested parties. For the purposes of this article, only the highest production period for each scenario is presented, that is, April 3rd to April 8th.

2. Simulation of the Normal Scenario

The model was set forth in the normal scenario (current), resembling its actual functioning as far as the system. The results obtained clearly indicate the problems endogenous to the system in terms of the process of product storage, with pre-cooling being a critical factor that affects the shipments. Fig. 9 illustrates the behavior of the bottleneck with respect to the quantity of incoming tomato from April 3rd to April 8th, representing the highest production during the current period. The graph shows the behavior of the bottleneck, with the accumulation of pallets above the input of product into the warehouse, as well as the costs that follow the same curve as the bottleneck. On day two, the quantity of incoming pallets is the same as that of the bottleneck.

Table V shows the storage of pallets of tomato, with the highest production from April 3rd to April 8th.

The data shows the quantity of total trucks required during the week at 10.32 trucks, and the number of pallets shipped was 206 pallets, surpassing the number of pallets in the bottleneck, which was 55. Table VI describes the costs of keeping the product in the warehouse as a consequence of the bottleneck and some of the costs, such as electricity, insurance, salaries, and maintenance costs, parameters included when calculating the cost. A comparison is made, considering the variation in production and seasons of harvest. It can be seen that the costs of keeping the products in the warehouse during average production is the highest, at \$610.95, due to the imbalance caused by the bottleneck.

3. Simulation of the Optimistic Scenario

In the optimistic scenario, the critical variables of the model were modified so that these changes would favor the system and the gaps found in the problem would be reduced, with the purpose of obtaining better results, such as the agilization of the product in shipment. Fig. 10 shows the behavior of the bottleneck as very similar to that of the normal scenario, with the quantity of incoming tomato higher from day one.

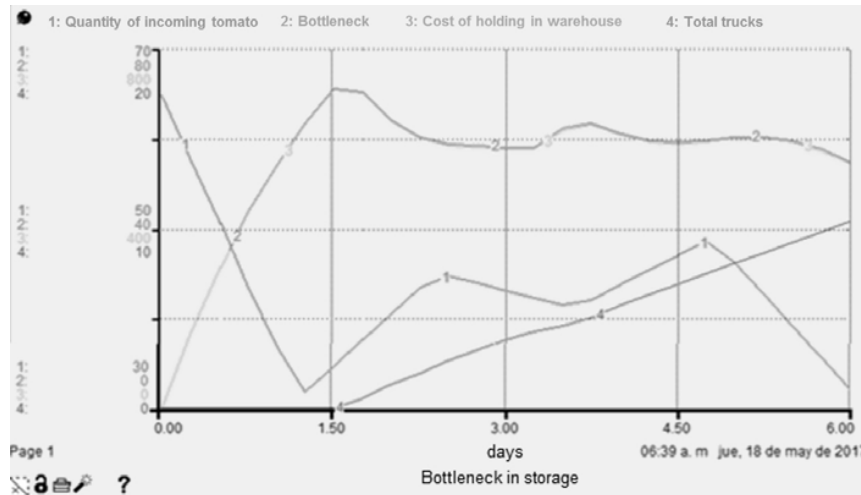

Fig. 9 Normal high production scenario, considering a bottleneck in the storage and shipping process

TABLE V
HIGH PRODUCTION ROMA TOMATO PALLET STORAGE IN THE NORMAL SCENARIO

Days	Quantity of incoming tomato (pallets)	Bottleneck	Total pallets Top Quality	Total pallets 2 nd Quality	Total Trucks
0	65	0	0	0	0
1	36.67	54.38	0	0	0
2	40.33	64.42	22.61	2.38	1.25
3	43	58.08	68.22	6.13	3.72
4	43.67	61.24	103.99	9.33	5.67
5	46.17	60.42	147.29	13.02	8.02
6	32	55.23	189.65	16.71	10.32

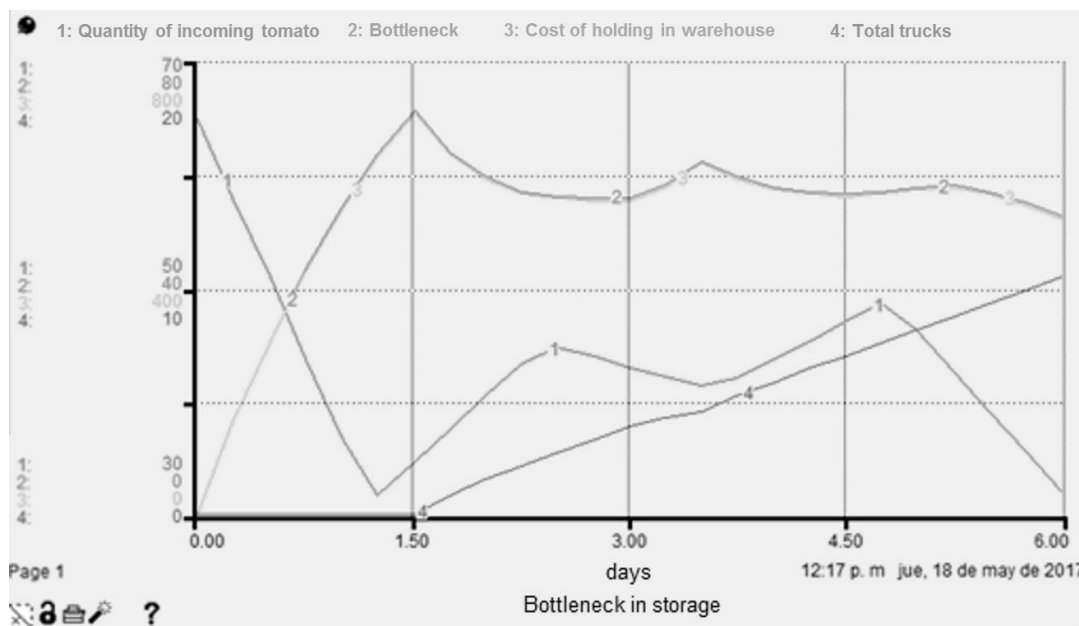

Fig. 10 Optimistic scenario of high production considering a bottleneck in the storage and shipping process

The need for trucks to transport the product and how it increases from day one can be seen in the trend. Table VII describes the total weekly accumulations in relation to Fig. 10.

According to the data, approximately 11 trucks are required to finish the week, with around 209 pallets in shipment and

52.77 pallets in inventory, causing the bottleneck.

Table VIII shows the costs generated due to having product in the warehouse as a result of the bottleneck. It can be seen that the costs of keeping the product in the warehouse in the average production (29 April to 5 May) are the highest, at \$

610.25, surpassing the costs generated during the highest production registered, due to a greater bottleneck during average production.

4. Simulation of the Pessimistic Scenario

For the pessimistic scenario the critical variables were modified in such a way that unfavorable conditions were present in the system to observe its behavior when stretched to the limit. Fig. 11 shows the pessimistic scenario considering a high production, illustrating the fluctuations in each of the variables that are measured.

TABLE VI
COSTS OF KEEPING THE PRODUCT IN THE WAREHOUSE IN THE NORMAL SCENARIO

Normal scenario		
Low harvest (7 to 14 March)	High harvest (3 to 8 April)	Medium harvest (29 April to 5 May)
\$ 318.27	\$ 548.53	\$ 610.95

Notes: It can be seen that in the normal scenario with the highest production the costs are lower with respect to the average production. For the purposes of this article the data of low and average harvest is included.

TABLE VII
HIGH PRODUCTION ROMA TOMATO PALLET STORAGE IN THE OPTIMISTIC SCENARIO

Days	Quantity of tomato incoming (pallets)	Bottleneck	Total pallets Top Quality	Total pallets 2nd Quality	Total Trucks
0	65	0	0	0	0
1	36.67	54.38	0	0	0
2	40.33	59.64	28.28	1.49	1.49
3	43	55.76	72.84	3.83	3.83
4	43.67	57.88	110.85	5.83	5.83
5	46.17	57.98	154.61	8.14	8.14
6	32	52.77	198.37	10.44	10.44

TABLE VIII
COSTS OF KEEPING THE PRODUCT IN THE WAREHOUSE: OPTIMISTIC SCENARIO

Optimistic scenario		
Low production (7 to 14 March)	High production (3 to 8 April)	Average production (29 April to 5 May)
\$ 314.58	\$ 524.09	\$ 610.95

It can be seen that on day one, the quantity in shipment and in the bottleneck is the same, although the quantity shipped in the end is greater than that of the bottleneck. Table IX illustrates the behavior in terms of requirements over several days, showing the evolution of the variables.

Table X shows the costs generated due to having product in the warehouse as a result of the bottleneck.



Fig.11 Pessimistic scenario of high production, considering a bottleneck in the storage and shipping process

TABLE IX
HIGH PRODUCTION ROMA TOMATO PALLET STORAGE IN THE PESSIMISTIC SCENARIO

Days	Quantity of incoming tomato (pallets)	Bottleneck	Total pallets Top Quality	Total pallets 2nd Quality	Total Trucks
0	65	0	0	0	0
1	36.67	54.38	0	0	0
2	40.33	89.42	0	0	0
3	43	105.49	22.61	4.33	1.35
4	43.67	104.64	62.61	7.31	3.5
5	46.17	123.83	86.61	10.28	4.84
6	32	128.1	118.61	14.87	6.67

TABLE X
COSTS OF KEEPING THE PRODUCT IN THE WAREHOUSE IN THE PESSIMISTIC SCENARIO

Pessimistic scenario		
Low production (7 to 14 March)	Low production (7 to 14 March)	Low production (7 to 14 March)
\$ 519.25	\$ 519.25	\$ 519.25

D. Communication Phase

1. User Interface

The interface has been developed in accordance with the interests of the production manager and administration, selecting the highest priority logistics performance. The interface is shown in Fig. 12.

It can be seen that the interface allows the user to simply press the buttons to carry out the simulations, with the option of modifying the most sensitive parameters and they are shown in behavioral graphs about the variables of costs, bottlenecks, and product in warehouse. Each section contains instructions to make it more user-friendly.

VI. CONCLUSIONS AND FUTURE WORK

The objective of this project was to develop quantitative scenarios of the Storage process for an agricultural company from southern Sonora and through these facilitate decision

making by developing the user interface. The way in which this objective can be reached is by entering indicators into the user interface to recognize which policies can be modified.

The conclusions are given from two perspectives: the theoretical and the practical. From the theoretical perspective, the methodology of system dynamics through simulation is a tool that generates solutions in order to look at different ways of complex behavior through the observation of data and graphs in a specific time horizon, which are easy to understand for people who are not necessarily experts in modeling.

On the other hand, from the practical perspective, the applications of logistics concepts in the agrifood business re attracting greater interest from investors in this sector in Mexico. This is reflected by the fact that the companies of the northeast region --where this company under study is located-- is an example of the fact that by working closely together with the university, it is possible to develop these kinds of quantitative solutions based on reference models which have been developed in other countries of the world as successful cases.

Finally, the case study represents a practical experience that can be consulted and used as a reference of realistic applications using system dynamics, which in spite of its complexity, can also be user-friendly.

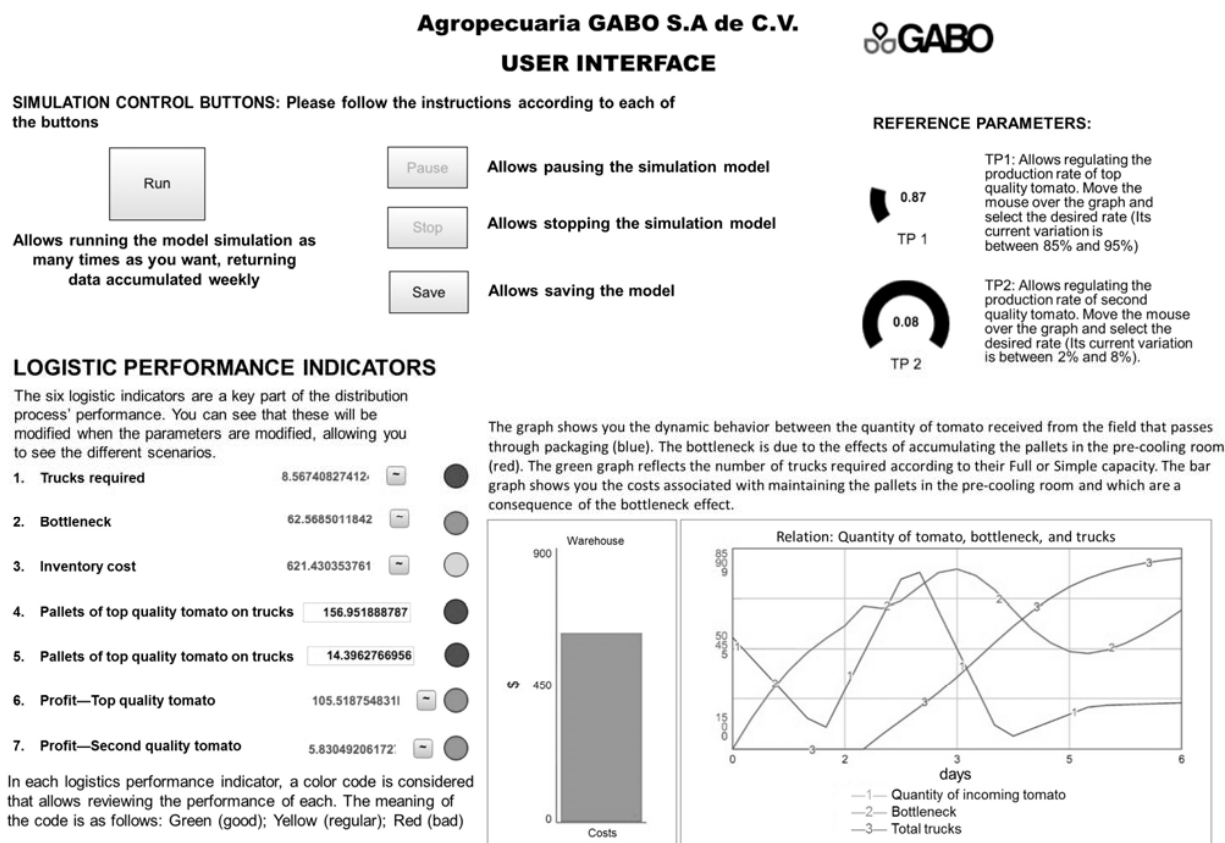

Fig. 12 User interface

Future work represents the following two challenges: first, in the short term, to develop a thesis with a postgraduate

student to connect each of the supply and production links to the distribution model presented here; thus, generating a more robust model (the entire supply chain of the Roma tomato product). This will allow observation of the behavioral logic according to the current status of the Roma tomato product, the highest demand product and of greatest interest to the company. This can be implemented by the company to support and improve decision making. Second, the short term challenge is to adapt the model for the other products according to the season and current processes, taking advantage of the upcoming design of a drone prototype for 2018 with applications in the agricultural industry for gathering data.

ACKNOWLEDGMENT

The authors, E.A.L.L; M.A.V.L, J.G.O.C. and A.A.N.F. As part of the National Laboratory in Transportation and Logistics-Consolidation Systems, the authors are grateful for the support received through the National Science and Technology Council of Mexico (CONACYT) through the "National Laboratories" program. At the same time, we thank the determination and effort of the Mexican Association of Logistics and Supply Chain, A.C. [AML] and the Mexican Institute of Transportation [IMT] for the development of the internationally recognized collaboration platform that is currently the International Logistics and Supply Chain Congress [CiLOG]. Likewise, the funding from the ITSON

REFERENCES

- [1] J. Van der Vost and J. Snels (2014, Enero). The World Bank Group. Retrieved from <http://documents.worldbank.org/curated/en/518411468060560130/pdf/858250WP0Posit00Box382162B00PUBLIC0.pdf>.
- [2] FAO. (2016). Organización de las Naciones Unidas para la Alimentación y la Agricultura. Retrieved from <http://www.fao.org/docrep/006/w0073s/w0073s0w.htm>.
- [3] SAGARPA. (Octubre de 2015). Programa Nacional de Agrologística. México.
- [4] SAGARPA. (2011). Secretaría de Agricultura Ganadería del Desarrollo Rural pesca y Alimentación. Obtenido de SAGARPA: http://www.sagarpa.gob.mx/agronegocios/Documents/estudios_economicos/escenariobase/perspectivalp_11-20.pdf.
- [5] DOF: 18/12/2013 - Reglas de Operación del Programa de Productividad y Competitividad Agroalimentaria.
- [6] FAO. (2014). Organización de las Naciones Unidas para la Alimentación y la Agricultura. Retrieved from <http://www.fao.org/3/a-i3592s.pdf>.
- [7] FAO-FAOSTAT. (febrero de 2010). Food and agriculture organization of the United Nations. Obtenido de Agricultura and consumer protection: <http://www.fao.org/ag/portal/ag-home/en/>.
- [8] SAGARPA-SIAP. (2010). Sistema de información agropecuaria de consulta. México.
- [9] F. Caraveo, and M. Gómez, "La agroindustria y la organización de productores en México". México: CIESTAAM-PIIAI, 1991.
- [10] C. Siller, "Importancia económica de la horticultura en México". Mazatlan, 1999
- [11] SIAP, "Atlas, Sonora infografía agroalimentaria". Mexico, 2015.
- [12] SAGARPA-SIAP. (2012). Sistema de información agropecuaria de consulta. México.
- [13] SAGARHPA. (2016, Octubre 27). Secretaría de Agricultura, Ganadería, Recursos Hidráulicos, Pesca y Acuicultura. Retrieved from http://sagarhpa.sonora.gob.mx/portal_sagarhpa/noticias/93-agricultura/183-cultivo-tomate-sonora.html.
- [14] R. Kaufman, "Planificación mega. Herramientas prácticas para el éxito organizacional". Castello de la plana: Publicaciones de la Universitat Jaume I. D.L., 2004.
- [15] J. R. Santana and J. C. Navarro, Plan estratégico de Agropecuaria GABO. Cd Obregon Sonora. 2016.
- [16] Empresa agropecuaria. (2017, Septiembre 30). Organigrama. Cd. Obregón, Sonora, México.
- [17] O. Sandra, "Modelo flexible en logística inversa. Universidad Federal de Santa Catarina", 2015.
- [18] J. L. García, F. C. Romero and O. Mayorga, "Modelado del sistema logístico de la cadena productiva de la papa empleando dinámica de sistemas". Revista Avances Investigación en Ingeniería, 2015, 86-93.
- [19] D. Gómez, M. Zuluaga, and S. Hoyos. (2009, Agosto). ECSIM. Retrieved from <http://www.ecsim.org/vista/archivos/metodologia%20y%20escenarios%20colombia.pdf>.
- [20] J. Veerman, J, "El Círculo Dorado". Ministry of Economics Affairs, 2013.
- [21] E. V. Velazquez, Canales de distribución y logística. Retrieved from http://www.ariat.org.mx/BibliotecasDigitales/economico_administrativo/Canales_de_distribucion_y_logistica.pdf.
- [22] Council of Supply Chain Management Professionals (CSCMP). (22 de Abril de 2017). Obtenido de Council of Supply Chain Management Professionals (CSCMP): <https://cscmp.org/iMISO/CSCMP/>.
- [23] R. H. Ballou, "Logística- Administración de la cadena de suministros". México: Quinta edición, 2004.
- [24] S. Crone, "Distribución y logística". Recuperado el 2014, de <http://www.distribucion-y-logistica.com/logistica/definiciones/logistica-definicion.html>.
- [25] J. Arvis, D. Savslasky, L. Ojala, B. Shepherd, C. Busch, and A. Raj, "Connecting to compete 2014", trade logistics in the global economy. The World Bank. Washington DC: The World Bank, 2014.
- [26] E. A. Lagarda-Leyva, "Metodología de planeación estratégica y escenarios con dinámica de sistemas", ITSON, Mexico, 2012.
- [27] C. Del Río, "Adquisiciones y abastecimientos". Mexico, D. F.: Thomson, 2002.
- [28] J. H. Chavez, and R. Torres-Rabello, "Supply Chain Management, logrando ventajas competitivas a través de la gestión de la cadena de suministro" (2a ed.). Santiago de Chile, Chile: RiL Editores, 2012.
- [29] J. Aracil, and F. Gordillo, "Dinámica de Sistemas". Alianza Editorial, 2005.
- [30] P. Kotler, and G. Armstrong, "Marketing". México: Pearson, 2012.
- [31] C. Lamb, J. Ail, and C. McDaniel, "Marketing". Distrito Federal, México: Changage Learning, 2011.
- [32] L.V. Bertalanffy, "Teoría General de los Sistemas. Fundamentos, desarrollo, aplicaciones". Ciudad de México: Fondo de Cultura Económica, 1976.
- [33] C.W. Churchman, "El Enfoque de Sistemas". México: Diana. 1973.
- [34] O. Johansen, O. "Introducción a la Teoría General de Sistemas". México: LIMUSA. 1993.
- [35] P. Senge, C. Roberts, and R. Ross, "La quinta disciplina en la práctica: estrategias y herramientas para construir la organización abierta al aprendizaje". Buenos aires: Granica, 2006.
- [36] J. W. Forrester, J. W., "Dinámica Industrial". Buenos Aires: Ateneo, 1981.
- [37] J. D. Sterman, J. D., "Business Dynamics; Systems Thinking and Modeling for a Complex World". United States: McGraw Hill, 2000.
- [38] M. Silvio, "Simulación dinámica por ordenador". En M. S. Alberto, Simulación dinámica por ordenador. Madrid: Alianzas Editorial, 1988.
- [39] J. Ogilvy, "Education in the information age:scenarios, equality and equaly". Barkeley, CA, USA: GBN, 2006.
- [40] Y. Tseng, W. Wang, and M. Weiyang, "A System Dynamics Model of Evolving Supply Chain Relationships and Inter-firm Trust". Tunghai University, Taiwan, Business Administration. Massachusetts: System Dynamics, 2012.
- [41] J. Aracil, and F. Gordillo, "Dinámica de sistemas". Madrid, España: Isdefe, 1995.
- [42] E.A. Lagarda, A.A. Naranjo, A. Bueno, J. Portugal, and J. Velarde. "Proyectos de vinculación para mejorar la fluidez de la cadena de Suministro en el sector agroalimentario: Experiencias y retos con estudiantes de posgrado y licenciatura", ITSON, Cd, Obregón, Sonora, México, 2017.
- [43] R. García, S. Romero, and T. Mayorga T. "Modelado del sistema logístico de la cadena productiva de la papa empleando dinámica de sistemas". AVANCES Investigación en Ingeniería, 2015, Vol. 11 - No. 2.
- [44] A. K. Abdel-Fattah, A. B. El-Tawil, and N. A. Harraz, "An Integrated

Operational Research and System Dynamics Approach for Planning Decisions in Container Terminals", *International Journal of Mechanical, Aerospace, Industrial, Mechatronic and Manufacturing Engineering* Vol:7, No:10, 2013.

- [45] W. Michael, and S. Markus, "Transforming an agricultural trade organization: a system-dynamics-based intervention", *System Dynamics Review* Volume 18, Issue 3, Autumn (Fall) 2002 Pages 381–401.
- [46] E. Lagarda-Leyva, J. Portugal, A. Naranjo, L. Burboa, and A. Noriega, "Using Scenarios: A Case Study of a Corporate of Chemical Distribution Business in Mexico", *XIV Encuentro Colombiano de Dinámica de Sistemas*, Universidad Pontificia Bolivariana, Medellín, Colombia. 2016.
- [47] M. I. Daphne, Verreth, G. Emvalomatis, F. Bunte, R. Kemp, Alfons G. J. M., and Oude Lansink, "Price Transmission, International Trade, and Asymmetric Relationships in the Dutch Agri-Food Chain", *Agribusinesses an International Journal*, 2015.