

Study and Analysis of Permeable Articulated Concrete Blocks Pavement: With Reference to Indian Context

Shrikant Charhate, Gayatri Deshpande

Abstract—Permeable pavements have significant benefits like managing runoff, infiltration, and carrying traffic over conventional pavements in terms of sustainability and environmental impact. Some of the countries are using this technique, especially at locations where durability and other parameters are of importance in nature; however, sparse work has been done on this concept. In India, this is yet to be adopted. In this work, the progress in the characterization and development of Permeable Articulated Concrete Blocks (PACB) pavement design is described and discussed with reference to Indian conditions. The experimentation and in-depth analysis was carried out considering conditions like soil erosion, water logging, and dust which are significant challenges caused due to impermeability of pavement. Concrete blocks with size 16.5''x 6.5''x 7'' consisting of arch shape (4'') at beneath and ½'' PVC holes for articulation were casted. These blocks were tested for flexural strength. The articulation process was done with nylon ropes forming series of concrete block system. The total spacing between the blocks was kept about 8 to 10% of total area. The hydraulic testing was carried out by placing the articulated blocks with the combination of layers of soil, geotextile, clean angular aggregate. This was done to see the percentage of seepage through the entire system. The experimental results showed that with the shape of concrete block the flexural strength achieved was beyond the permissible limit. Such blocks with the combination could be very useful innovation in Indian conditions and useful at various locations compared to the traditional blocks as an alternative for long term sustainability.

Keywords—Connections, geotextile, permeable ACB, pavements, stone base.

I. INTRODUCTION

PACB creates an efficient pavement together with arched reservoir to maximize on site water capacity. This system is a combination of modern day concept and traditional concept used for decades to create the transformation in permeable paving solution. This system is based upon patented arch design in the middle of an articulating concrete block to create an internal storage chamber that can be used as a reservoir for water runoff, while simultaneously providing strength for heavy vehicular loads. This system provides infiltration, storage, detention and a paving surface. The installation of PACB systems is performed so as to maintain intimate contact between the blocks, aggregates, the geotextile filter and the sub grade that the system is intended to protect. Proper design of the filter layer, i.e. geotextile is done for the successful performance of the P-ACB system. Brattebo and

Booth [1] examined long-term effectiveness of permeable pavement and recommended as an alternative to traditional impervious asphalt pavement in a parking area. Shackel [2] explained overall in the paper which helps us to achieve a better understanding of the in-service behaviour of Concrete Block Pavement (CBP) and explains the role of factors such as paver shape, joint width and the choice of jointing sand. Kazemi [3] investigated the hydraulic performance of this permeable pavement system and found that, when clogged, the system captured 30-40% of runoff volumes and that proper maintenance completely restored infiltration capacity. Schloz and Grabowiecki [4] explained about development of PPS as an integral part of sustainable drainage systems is reviewed in the context of traditional and modern urban drainage. Grace [5] studied and proved that Permeable articulated concrete block/mats (P-ACBMs) was historically used for stabilization and erosion control but are now being used for road, parking, and other surfaces as a Storm water Control Measures (SCM) due to their great ability to infiltrate runoff. Peter Weiss et al. gave extensive review of full-depth permeable pavements including porous asphalt, pervious concrete, and permeable interlocking concrete paver (PICP) is done. Brief section on articulated concrete blocks/mats is also included. Mulligan [6] after her research confirmed that pervious concrete does in fact provide a lower compressive strength than that of conventional concrete, compressive strengths in acceptable mixtures only reached 1700 psi, i.e. 11.72 N/mm². Extremely high permeability rates were achieved in most of the mixtures regardless of the compressive strength. Chopra [7] evaluated the performance of different permeable pavement system sections developed by Pavedrain under different conditions and examine the effects of sediment loading and rejuvenation on the infiltration capacity. Borgwardt [8] shows that the infiltration performance decreases significantly after a few years, but still infiltrates rainfall and runoff from high intensity storms.

The main objectives to do this work are to increase water quantity storage, improve water quality and prevent soil erosion and water logging problems. Increase in ease of placement and handling of concrete blocks on site is also achieved.

II. SOME PARAMETERS

A. Concrete Blocks

The concrete blocks are made of precast concrete. Blocks

Gayatri Deshpande is with the Pillai HOC College of Engineering & Technology, India (e-mail: gayatrid676@gmail.com).

consist of strongest geometric arch shape at underside. The blocks are cast into non-interlocking shapes. Blocks are sound and free from any defects that would interfere proper placement. The blocks are cabled into mats. Blocks to be cabled are having pre-formed holes cast in them for placement of the cable. The holes should be smooth to prevent damage to the connections.

B. Connections

Individual blocks that are connected into a mat are often referred to as cabled systems. The cable may consist of ropes, polyester revetment cable, or galvanized or stainless steel cable used as a connection. The individual blocks may be assembled into mats offsite or constructed onsite by hand placement. The cables shall be inserted into the mats in such a manner to form lifting loops at one end of the mat with the corresponding cable ends spliced together to form a lifting loop at the other end of the mat.

C. Geotextiles

Geotextiles are typically used to retain the soil particles serving as the sub grade for the PACBs. Geotextile may be woven or nonwoven and may be composed of multifilament yarns or monofilament yarns. Grading and compaction of soil should be done before placing geotextile. Standard flowchart is required for selecting geotextile. Soil sample beneath used in the pavement is to be tested. After doing the tests, we come to know the type of soil constituent. Geotextile provides functions such as filtration, drainage, reinforcement, cushion, waterproofing and separation.

D. Stone Base

The geotextile should be used on the bottom of the installation to prevent contamination of clean base stone. Clean, angular aggregates with no fines are used which is used as a levelling course directly beneath the blocks. The aggregate bedding layer shall be graded to a smooth plane surface to ensure that intimate contact is achieved between the legs of the permeable articulating concrete block/mats and the aggregate bedding layer. All base stone shall be of uniform size. Levelling course of aggregate shall be rolled and then compacted with a plate compactor in both the perpendicular and parallel directions in the area of coverage.

E. Soil

Analysis of the soil is done to select appropriate geotextile to be used in basement layer for pavement. Depending upon soil characteristics geotextile is selected. Selection of geotextile will be done as per standard flowchart. Selection, specification and characterization of proper geotextile is very important for successful and effective results of model.

III. METHODOLOGY

Methodology is divided into three different steps which consist of first geotextile selection on basis of soil, then second design as well as casting of concrete blocks with articulation, third is preparation of model box and calculation of drainage and storage capacity on model. Soil was collected

from Pillai HOCL Educational Campus ground and was tested and analyzed with respect to standard geotextile selection flowchart used for permeable pavements. The soil at upper side was removed and then with help of dolly the soil was excavated for testing. Results of tests like permeability of soil, undrained shear strength and plasticity index of soil is of major importance for selection of geotextile. Certain basic and physical characteristics were also determined to know the behavior of soil under load. Soil should be clean and should not contain any other material in it. Concrete blocks were designed as per specifications and requirement. The concrete blocks are casted by using Ready Mix Concrete. Concrete of M25 grade is used to make the blocks, as the minimum requirement of compressive strength is 27.5 N/mm². First step before placing of concrete is oiling of mould. After that concrete is filled in three layers by using vibrating table and then finished. Blocks are kept for curing for 28 days. A rectangular concrete block having non-interlocking shape with high density and storage carrying capacity was designed. Mould was prepared by using G.I. steel and arch shape was given to it by using G.I. steel pipe welded to the mould for casting of concrete blocks. Nine concrete blocks were casted according to standard conditions. Articulation of concrete blocks through ½" PVC pipes using nylon ropes was done. Concrete blocks prepared have been tested using visual inspection as well as standard tests. Compressive strength was carried out after 7 days as well as 28 days. Flexural strength was calculated using standard IS specifications and compared with the range provided for the grade of the concrete. Water absorption test on concrete was performed using oven dry method. Density of concrete was calculated using formula mass divided by volume of concrete. A model box is prepared using granite as a strong base and which is surrounded by 10 mm thickness glass from four sides which will make the model to view transparent. Pipe arrangement is done at the outlet of the aggregates and soil layers for calculation of discharge through model. Materials are placed in layers superimposing each other to have intimate contact between them for best effective results. This layer includes tested soil as the sub base layer, geotextile as the base layer and which will be covered by using clean angular aggregates and the concrete blocks which are prepared. In model box, first 6" soil is laid and properly compacted after that approved geotextile is placed over it. Clean angular aggregates of 8" are superimposed over geotextile. Drainage capacity of the model through pipes provided is tested by calculating discharge using specific intensity of water. Specific intensity of water is controlled by doing marking on tap for proper results. Three readings are taken for each tests carried out in the project.

IV. RESULTS AND DISCUSSIONS

A. Analysis of Soil

Tests are conducted on soil to select the appropriate geotextile to be used for the particular soil condition. The following tests were conducted on soil in the lab.

1. Natural moisture content using Oven Dry method

2. Specific gravity of soil sample using Pycnometer
3. Field density by Core cutter method
4. Grain size analysis of soil by sieve analysis and hydrometer analysis
5. Permeability of soil by Variable Head method
6. Plasticity index
7. Undrained shear strength
8. California Bearing Ratio (CBR)

Results of the test are as follows:

- i. Natural moisture content using Oven Dry method: Natural moisture content test was carried out in lab was carried out in soil samples. Readings were taken of three samples by using Oven Dry Method. Average water content of three samples is calculated and it comes out to be 34.05%.
- ii. Specific gravity of soil sample using Pycnometer (G): Readings of specific gravity test of soil sample are taken by using Pycnometer. Average specific gravity is calculated by taking three samples and it comes out to be 2.10.
- iii. Field density by Core Cutter method: Field density of soil sample was carried out using Core Cutter method. Average field density of soil sample is 1.35.
- iv. Grain size analysis of soil by wet sieve analysis: Weight of soil sample taken for sieve analysis was 500 mg. Sieve analysis of soil was done by Grain size sieve analysis method. As, more than 50% of soil sample was passing through 0.075 mm, i.e. 75 μm, hydrometer analysis was conducted further.

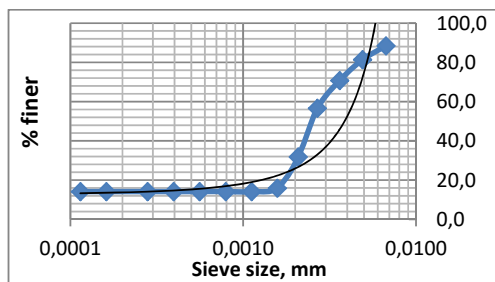

Fig. 1 Particle size distribution curve

- v. Grain size distribution by hydrometer analysis: Mass of soil taken was 50 mg which is the part of soil passing through 75 μm sieve. Type of hydrometer used for this is 151H. Temperature was kept constant at 32 °C. Calibration of hydrometer was done as per standard procedure. Effective depth (He) corresponding to each general hydrometer reading was calculated. Composite correction (C) was calculated and it is applied in observed hydrometer reading to obtain corrected hydrometer reading. Diameter (D) of soil particle and corresponding percentage finer (N) was calculated using formula. Fig. 1 shows particle size distribution curve which indicates fine grained soil. From grain size distribution curve, it is found that, soil consists of 31.8% Clay (passing through 0.002 mm), 68.2% silt (in between 0.075 to 0.002 mm). Hence, soil is classified as silty clay loam.

- vi. Permeability of Soil by Variable Head Method: The coefficient of permeability of given soil obtained from test is 9.58×10^{-10} m/sec, i.e. 9.58×10^{-8} cm/sec. According to USBR, the above soils having the coefficient of permeability between 10^{-9} to 10^{-6} cm/sec are designated as very poor drainage property and the type of soil is silty loam clay. Hence, this soil sample is having very less drainage capacity.
- vii. Plasticity index (PI): Plastic limit (PL) and Liquid limit (LL) of soil sample was calculated according to IS 2720-V (1985) for three samples and readings were taken. Plastic limit of soil is 32%. Liquid limit was obtained from flow curve corresponding to 25 blows and comes to be 54% as shown in Fig. 2. From that readings Plasticity index is calculated by deducting plastic limit value from Liquid limit value of soil sample and is 22%.

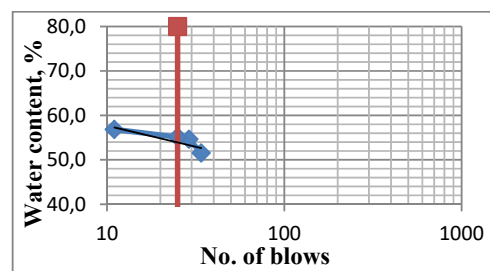

Fig. 2 Flow curve

- viii. Undrained shear strength was calculated as per formula and comes out to be 14 kPa.
- ix. California Bearing Ratio (CBR): As per IS: 2720 (Part 16)1987 The load corresponding to 2.5 mm and 5 mm penetration values is obtained from load penetration curve as shown in Fig. 3. Standard Load Test used in C.B.R. for 2.5 mm and 5 mm penetration depth (mm) are 1370 kg/cm² and 2055 kg/cm². CBR value for 2.5 mm penetration is 3.5 and for 5 mm penetration is 3. As CBR value of 2.5 mm penetration is greater than CBR value of mm penetration, therefore CBR value 3.5 is used.

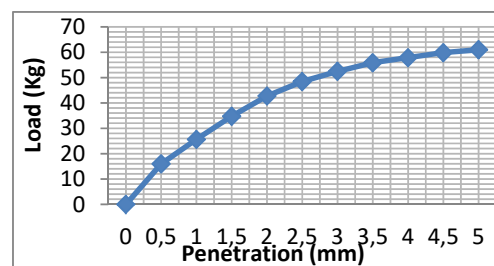

Fig. 3 Load penetration curve

As the condition, the flowchart satisfies the geotextile to be used is [O95 < 70 SIEVE (0.2 mm)]. Geotextile used in this project is 150 GSM Polypropylene Non-Woven Geotextile having specifications tensile strength 8 kN/m, tensile elongation 50%, thickness 1.10 mm, etc.

B. Analysis of Concrete Blocks

Concrete Block size was decided by trial and error method and referring standard specifications. In the first attempt, block was prepared having two arch shape of (4'') which failed structurally while casting as shown in Fig. 4.



Fig. 4 First trial of concrete block

Then new trial was made having block size (16.5''x 6.5''x 7'') which was permissible in all cases as shown in Fig. 5. Slump should be minimum, i.e. 60 mm of this concrete. Blocks are kept for 28 days curing to check compressive strength and flexural strength of the block.



Fig. 5 Actual concrete block

M25 grade concrete was used for casting of concrete having W/c ratio 0.40. Slump Cone Test was performed before casting on fresh concrete and it is 60 mm. The following tests were performed on concrete block, and the results are as follows:

- i. Water Absorption Test: Water absorption test was conducted on the concrete block casted by using oven dry method. Three readings were taken. Average water absorption of concrete blocks is 1.35% which is as per limit required. This shows that the concrete will not absorb more water and hence it will be more durable.

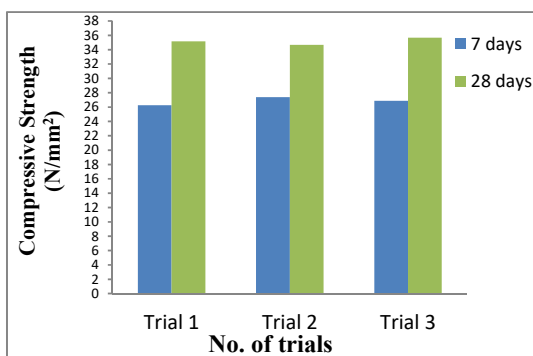

Fig. 6 Compressive strength results

- ii. Compressive Strength Test: Compressive Strength was conducted on concrete block having size 150 mm x 150

mm. After 7 days and 28 days duration of curing, compressive strength was carried out. After 7 days compressive strength comes out to be 26.85 N/mm² and after 28 days it comes out to be 35.17 N/mm² as shown in Fig. 6. As the grade of the concrete used is M25, compressive strength achieved is more than required and has high strength.

- iii. Flexural Strength Test: Flexural test was carried out on concrete blocks after 28 days of curing using Two-Point loading method. Flexural strength is calculated using (1)

$$Fb = \frac{PL}{bd^2} \quad (1)$$

Average strength was found to be 3.63 N/mm² which is much more than required. Flexural strength as per standard is given by the formula $Fs = 0.7 * \sqrt{fck}$, where fck is grade of concrete which is 25 in this case. Therefore $Fs = 0.7 * \sqrt{25} = 3.5$ N/mm². So, this block is having maximum flexural strength. Fig. 7 shows the block after flexural strength testing.



Fig. 7 Concrete block after flexural strength

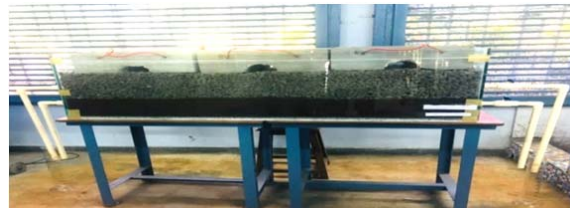

Fig. 8 Permeable articulating concrete blocks model

C. Experimentation on Model for Hydraulic Characteristics

PACB pavement model is prepared of size 60'' length, 24'' width and 22'' height and is being tested for hydraulic characteristics. The blocks are made as open cell. Open-cell block systems provide an overall open area ranging from 8 to 10 per cent for the system. The open area allows water to pass into them and do the vertical filtration of water. Fig. 9 indicates the cross sectional view of the model in perpendicular direction and detailed view of concrete block. Discharge is calculated on model which is shown in Fig. 8 by using specific intensity of water passing vertically through the components of the model. Specific intensity of water was decided by doing marking on tap and was kept constant throughout experimentation. Time is calculated by using stop watch for filling the volume of 15-litre cylinder. On basis of that discharge is calculated for 3 times by dividing volume by time as per standard formula. Average time required for filling 15-litre cylinder, i.e. 0.015 m³ on model was 77 s and discharge calculated comes to be 0.00019 m³/ sec. Actual discharge of water is also calculated using the same method

with same intensity without model for comparison. Average time required for filling the 0.015 m^3 is 51 s and average discharge calculated comes out to be $0.00029 \text{ m}^3/\text{sec}$. An arch

shape of one block is of 4" diameter which will store water equivalent to that, which will be more effective when it will be calculated for cumulative area.

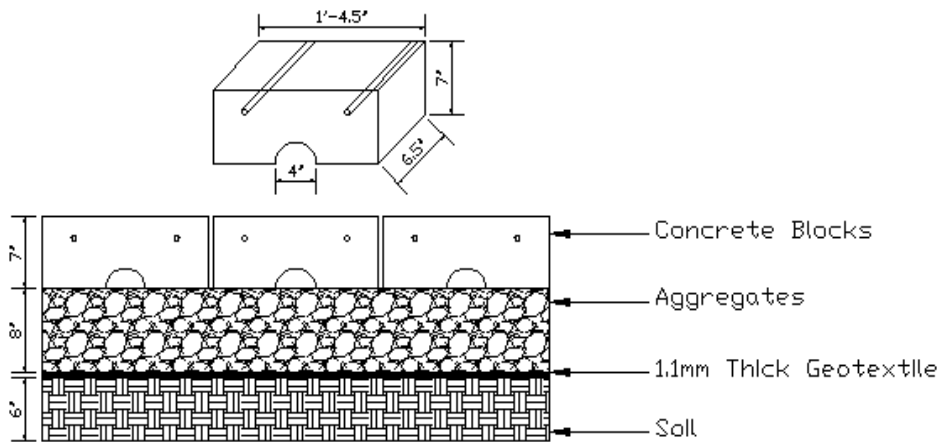

Fig. 9 Cross sectional view of PACB model

V. CONCLUSIONS

Concrete blocks were designed using trial and error method. However, it was designed considering two arch shapes at sides, it was observed that in casting only it failed structurally. Therefore, attempt was done to cast with one arch shape beneath the block. Flexural test results were found to be in permissible limits. PVC pipes used in the holes for articulation gave a very good strength to withstand as it acts like reinforcement to it. Using these concrete blocks, model was prepared for hydraulic testing which shows that it gives good drainage capacity and storage capacity due to arch shape. Cumulative effect of arch shape will be very useful for water storage of large area. In India, since at many sites traditional solution is given, this would be one of the solution for long term sustainability. This could be solution for problems like soil erosion and water logging in Indian conditions for the places like parking lots, gardens, and footpaths.

ACKNOWLEDGMENT

It is a privilege for us to get help from Manas Geotech Sales for providing geotextile. We acknowledge the help provided by Ms. Dipti Randeria, Consulting Structural Engineer. We have been greatly benefited by their valuable suggestions and ideas. We would like to thank J. M. Mhatre Infra Private Limited for providing help for sample testing in lab.

REFERENCES

- [1] Benjamin O. Brattebo, Derek B. Booth (2003), "Long-term storm water quantity and quality performance of permeable pavement systems", *Water Research* 37 (2003) 4369-4376, July 2003.
- [2] Brian Shackel (2006) "Design of Permeable Paving Subject to Traffic", 8th International Conference on Concrete Block Paving, November 2006.
- [3] Kazemi (2013) "Evaluating the effectiveness and hydrological performance of green infrastructure storm water control measures", December 2013.
- [4] Miklas Scholz, Piotr Grabowiecki (2007) "Review of permeable pavement systems" Elsevier Science Direct, *Building and Environment* 42(2007) 3830-3836 November 2006.

- [5] Peter Weiss (2015) "Permeable Pavements in cold Climates: State of the Art and Cold Climate Case Studies", June 2015.
- [6] Report by Ann Marie Mulligan (2005) "Attainable Compressive Strength of Pervious Concrete" June 2005.
- [7] Report by Manoj Chopra (2016) "PAVEDRAIN Permeable Pavements", Stormwater Management Academy, Orlando, May 2016.
- [8] Soenke Borgwardt (2015), "In-Situ Infiltration Performance of Permeable Concrete Block Pavement – New Results", September 2015.