

Electromagnetic Tuned Mass Damper Approach for Regenerative Suspension

S. Kopylov, C. Z. Bo

Abstract—This study is aimed at exploring the possibility of energy recovery through the suppression of vibrations. The article describes design of electromagnetic dynamic damper. The magnetic part of the device performs the function of a tuned mass damper, thereby providing both energy regeneration and damping properties to the protected mass. According to the theory of tuned mass damper, equations of mathematical models were obtained. Then, under given properties of current system, amplitude frequency response was investigated. Therefore, main ideas and methods for further research were defined.

Keywords—Electromagnetic damper, oscillations with two degrees of freedom, regeneration systems, tuned mass damper.

I. INTRODUCTION

Growing interest in electric and hybrid vehicles has been observed in recent years. Saving of electric energy and creating of infrastructure for such vehicles has become one of the most important tasks facing researchers.

The process of capturing energy from the environment and converting it into usable electrical energy is known as energy regeneration [1]. There are two main methods of energy regeneration in road vehicles: braking systems and suspension systems.

This research provides a regenerative suspension system. Construction with two degrees of freedom consisting of an electromagnetic damper, recovering the kinetic energy due to vibrations, and solenoid which transforms it to the electrical energy was investigated.

In general, the aims of suspension are isolating the car body from the vibrations coming from the road surface and improving road handling by ensuring contact between tires and the road. Performance of suspension system significantly improves with a proper tuning of viscous dampers, commonly used to dampen the relative motion between car body and unsprung masses [2].

Generally, vehicle suspensions are designed to control the vehicle vibration by dissipating the vibration energy into heat, mostly by hydraulic dampers. If such dissipated energy can be recuperated, the estimated power gain would be an average of 100–400 W for a mid-size passenger car on an average road at 60 mph [3]. The novelty of this particular idea is using construction with diaphragm springs and magnets, performing the function of tuned mass damper, which is able to oscillate in a magnet field from a solenoid, in this way allowing it to carry out two functions simultaneously: recovering the kinetic

energy due to vibrations and damping the unsprung mass of the vehicle.

II. SYSTEM OF ELECTROMAGNETIC DAMPER

In general, the construction includes two parts: mechanical and electromagnetic. Mechanical part consists of a coil spring, which is responsible for dumping (damping) road oscillations. In turn, the electromagnetic part consists of two parts: diaphragm springs in Fig. 1, carrying permanent magnets, which perform the function of tuned mass damper, and the solenoid which is responsible for producing electric energy and damping road oscillations as well. The general view of construction is shown in Fig. 2.

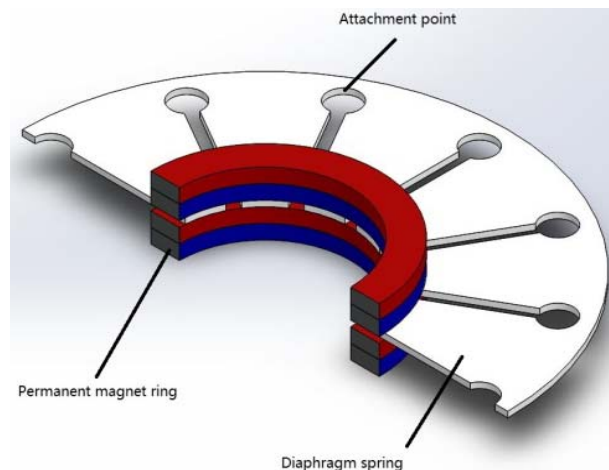

Fig. 1 Diaphragm spring

In Fig. 3, schematic view of construction and main parameters are shown, where M is a sprung mass with stiffness K , m is an unsprung mass with stiffness k , and x and y are the generalized coordinates.

For the initial analysis the current system will be excited by the periodic force $F \sin(\omega t)$, F as amplitude, ω as a cyclic frequency. The controllable force F_r plays the role of force which can affect the behavior of oscillations.

The objective of research is to provide a damper with two functions: damping and regeneration. The device should be able to operate under both direct current and alternating current.

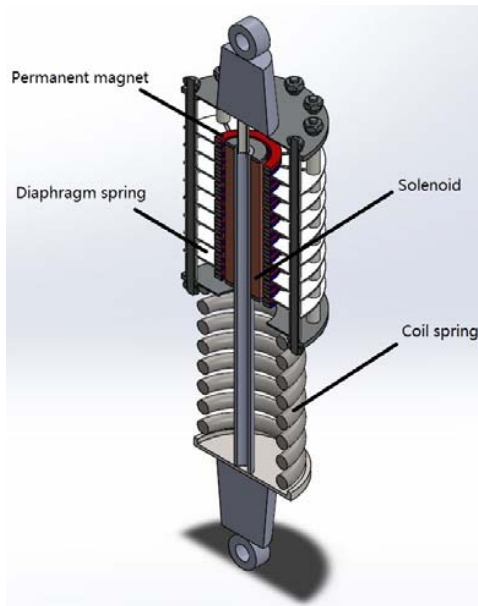

Fig. 2 General view

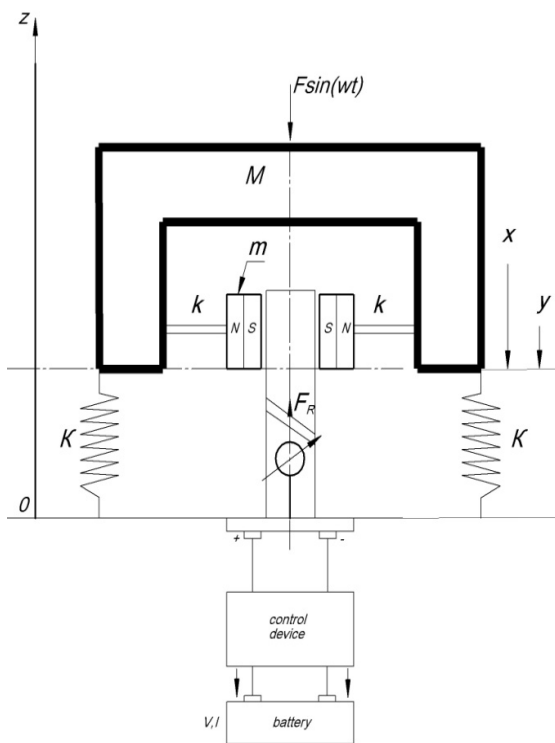

Fig. 3 Schematic view

For the first case, the wire (solenoid) is moving in a constant magnetic field. Then, acting on it, Lorentz force creates an electromotive force E , thereby, producing an electric energy, described by (1):

$$E = V \cdot l \cdot B \cdot \sin \alpha \quad (1)$$

where l is the length of wire, V is a velocity of wire moving, B is a magnetic field, and α is an angle between magnetic field vector and vector of wire velocity. In this way, the device does not carry out the function of damping, but is able to generate alternating current in the solenoid. It can be said that Lorentz force resists movement of the solenoid, depending on the velocity of movement. This kind of resistance further will be considered as a viscous coefficient for tuned mass damper. Providing that magnets will be configured as a tuned mass damper, more details will be examined in the following chapter.

For the second case, the solenoid is powered by an alternating current, and the character of current can influence the oscillations of magnets. Therefore, the device is able to control vibration from the road.

The question is how to combine two conditions of working and save damping and regenerative functions at the same time. The answer is located in the theory of tuned mass damper.

III. THE THEORY OF TUNED MASS DAMPER

A tuned mass damper (TMD), also known as a vibration absorber, is a mechanism applied in systems to suppress the mechanical vibrations by kinetic energy. Their application can provide comfort, sustainable operation, and regeneration kinetic energy. Such dampers are commonly realized with a frictional or hydraulic part that converts mechanical kinetic energy into heat [4]. The simplest model of such dampers will be considered in chapter IV.

The vibration absorber consists of a comparatively small vibratory system which is attached to the main mass. The natural frequency of the attached absorber is chosen to be equal to the frequency of the disturbing force. It will be shown then that the main mass does not vibrate at all, and that the small system vibrates in such a way that its spring force is at all instants equal and opposite to the disturbing force. Thus, there is no net force acting on the main mass, which will result in no vibration [5].

In general, there are two major types of TMD with absorbers: with damping and without damping. TMD with absorber without damping is tuned to the frequency of the disturbing force. Such an absorber is called a narrow-band absorber, as it does not eliminate the threat of structural oscillations, when the frequency of vibration is out of tuned range. However, the insertion of damping allows it to significantly widen the bandwidth of effective operation of TMD as shown in Fig. 4 [6]. Therefore, the problem of the optimal parameters of TMD with linear viscous friction has become the primary goal of research in this area [7].

As we can see, the curve with more optimal damping parameters belongs to the system with absorber and optimized damping.

The common method of optimization and methods for achieving efficiency of current system will be explained and considered in the next chapter.

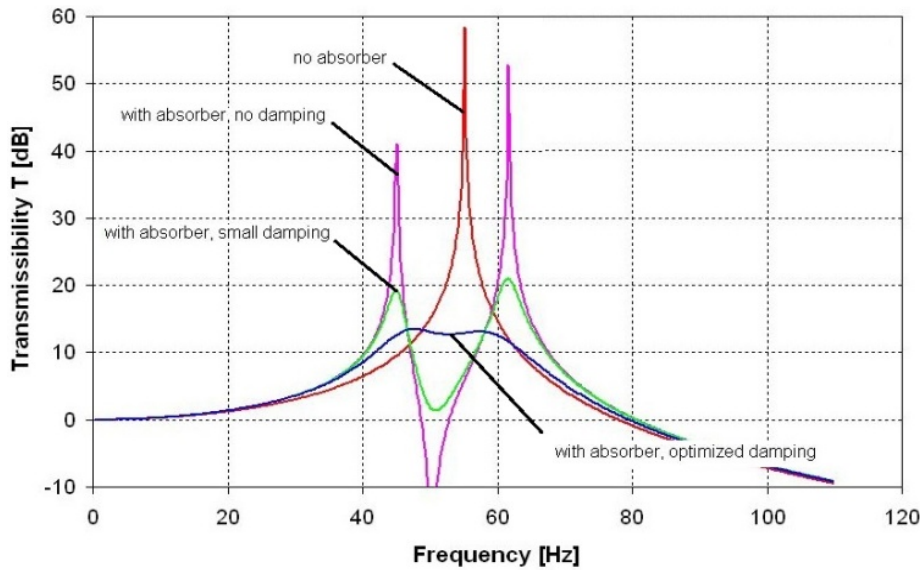

Fig. 4 Efficiency of tuned mass damper

IV. MATHEMATICAL MODEL

For TMD without damping, the scope of application is very limited. TMDs with damping are more effective in wide frequency ranges of external influences. Sensitivity to deviations from the optimal values of such dampers is lower than in the dampers without damping, which significantly increases the reliability of operation in service. The energy dissipation in the dampers is most often carried with the use of dampers with viscous friction.

In this chapter of the article, the oscillation system equipped TMD with viscous friction was considered.

To simplify the solution of the problem, in the beginning, the inelastic resistance of the protected mass is not considered, but in further researches about optimization of the oscillation system, an approximate estimate of the influence of this factor on the efficiency of the TMD will be made.

The differential equations of vibrations of the protected mass and the mass of the damper (2):

$$\begin{cases} M \cdot \ddot{x} + K \cdot x + k(x - y) + \mu_0(\dot{x} - \dot{y}) = K \cdot \eta(t) \\ m \cdot \ddot{y} + \mu_0(\dot{y} - \dot{x}) + k(y - x) = 0 \end{cases} \quad (2)$$

where M is the protected mass, K is the coil spring stiffness, m is the mass of TMD with damping coefficient μ_0 , k is the diaphragm spring stiffness, x, y their movement coordinates and $\eta(t)$ external impact, as shown in Fig. 5.

Using the method of operational calculus [8], the ratio of amplitude of the protected mass to amplitude of the input of external influence $\frac{A_{zp}}{A_\eta}$ and the ratio of amplitude of the damper mass to amplitude of the input of external influence $\frac{A_{zd}}{A_\eta}$ were defined, where the amplitude of the protected mass is A_{zp} , A_{zd} is the amplitude of damper, and A_η is the amplitude of input impact.

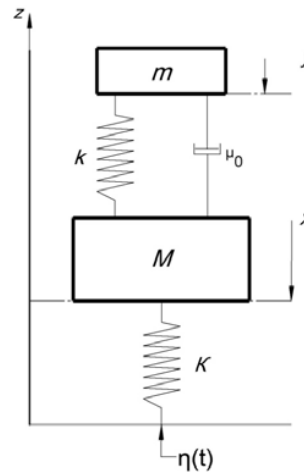

Fig. 5 Mathematical model

TABLE I
GENERAL PARAMETERS

Parameter	Value	Description
M	10 kg	Protected mass
m	2 kg	Damper mass
K	25000 N/mm	Spring stiffness
k	5000 N/mm	Diaphragm stiffness
μ_0	50	Damping coefficient

Therefore, for these parameters, amplitude-frequency response plot for tuned mass damper and protected mass was obtained in Fig. 6, where, I - the area of increasing amplitude, II - the area of reducing amplitude, III - the area of optimal parameters for the electromagnetic dynamic damper (EDD) for current system.

The greatest interest for further study is located in Section III, the section where the TMD vibrates at a greater amplitude than the amplitude of the input and thus makes the protected

mass oscillate with a smaller amplitude than the input impact. In this case, the damper has more kinetic energy than the energy of input impact. This in turn converts mechanical kinetic energy into electrical energy, by means of the oscillation of the EDD. In this case, the working frequency range of current system can vary from 72 to 84 Hz. Therefore, the EDD of this system performs two functions: the suppression of oscillations of the main mass and energy regeneration of suppressed fluctuations of the input impact, thereby answering the question posted above: how to combine two conditions of work and to maintain damping and regenerative function at the same time.

In order to get the best efficiency of producing electric energy, EDD needs to work in the frequency close to resonance condition. At the same time, that condition allows vibration reduction from the road.

For further research of behavior of that system, the problem

of choosing optimal parameters should be solved.

With the aim of obtaining sufficiently accurate and simple equations for the optimum parameters of the absorber, it is best to typically use a known property of a linear system with one damper. The ordinates of its presence on the frequency response are invariant points and do not depend on the value of damping. At these points, the curve of frequency response of the system, corresponding to different values of viscous coefficient, is intersected.

Setting and damping of the absorber are determined by minimizing the maximum ordinate of the frequency response of one or the other kinematic parameter of vibrations of the main mass at a given value of the relative weight of the damper. This in turn is prescribed on the basis of ensuring the required level of the chosen quality criterion, subject to the conditions of the strength of the elastic element and limitation on the motion of the damper [9].

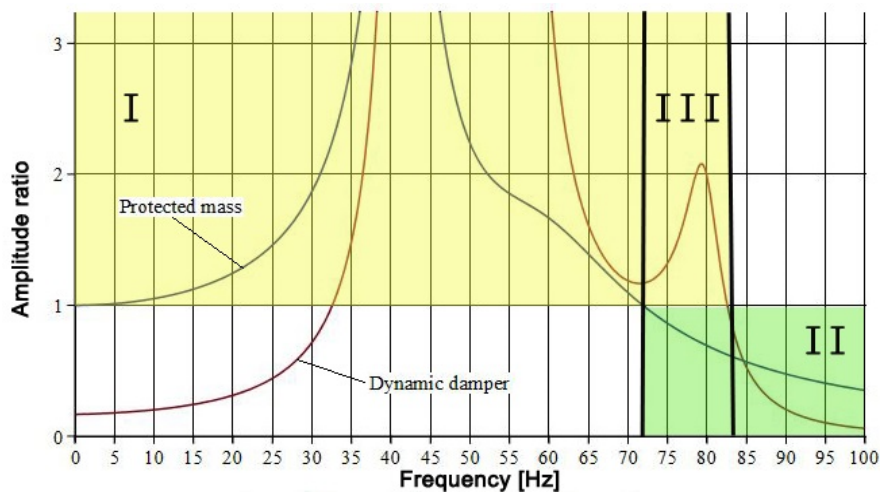

Fig. 6 Amplitude frequency response

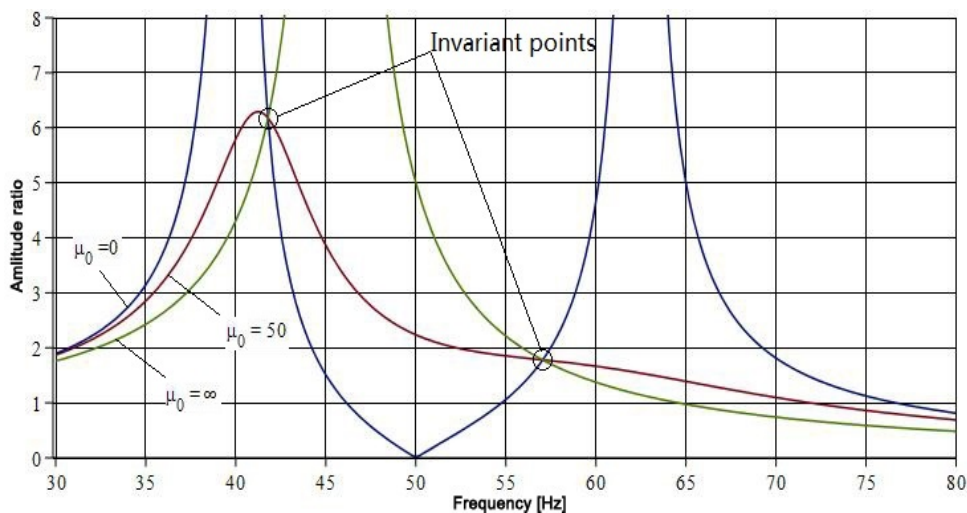

Fig. 7 Invariant points of current system

The amplitude of oscillations of the main mass, which is equipped with a damper, has two invariant points in Fig. 7.

The ordinates of these points, at a fixed value of relations of mass, depend only on settings of damper and under any values of viscous coefficient do not exceed the high frequency response and are located in the vicinity of these points [10].

The standard setting of the damper shall be appointed by minimizing the largest of the ordinates of invariant points, the viscous coefficient is chosen such that the tangents to the invariant points have the minimum slope. In this case, at least most of coordinates showing the amplitude of the main mass at the unstable frequency disturbance will be provided [11].

This common method of optimization is aimed at finding optimal parameters for damping. However, the aim of current research is to obtain optimal parameters for carrying out two functions at the same time: damping and regeneration.

For damping, important parameters are the protected mass, the mass of damper, and the viscous coefficient. Using the current method of optimization would be correct for only damping properties. Parameters for efficient regeneration are the values of velocity, acceleration, and amplitude of tuned mass damper. These parameters should be taken into consideration, for developing a complex method of optimization. Therefore, the optimization of system for two groups of independent parameters will be created in the further research work.

V.CONCLUSION

A further objective of the study is to create techniques for system optimization for two key parameters: the maximum efficiency of regeneration of electrical energy and the high damping properties of the system. Another important task is to expand the operating range and to define the scope of application for such dampers, taking into consideration the transition process.

The next step is to learn a second condition of device operation, when the solenoid is excited by an alternating current of a certain frequency, thereby affecting the oscillations of the TMD and the protected mass. For that case of movement, there is also a need to create a complex method of optimization. According to the results of optimization, the efficiency of the overall system and the feasibility of this method will be obtained.

Additionally, the system excited by an alternating current of a certain frequency needs to be controlled. Therefore, developing of a program and algorithm for controlling, and methods of control becomes a task of this research.

The final step of the research is to create methods of optimization for two conditions of operation at the same time and to control the current system with optimal parameters. This includes high efficiency of regeneration and damping functions.

REFERENCES

- [1] P. Li, L. Zuo, and J. Lu, "Effect of damping coefficient on power generated & comfort index in energy regenerative damper for automobile suspension system," *Systems, Man and Cybernetics (SMC)*, 2014 IEEE International Conference, pp. 2513-2518, December 2014.
- [2] M. Zaouia, N. Benamrouche, and A. Djerdir, "Study and analysis of an Electromagnetic Energy Recovery Damper (EERD) for automotive applications," *Electrical Machines (ICEM)*, 2012 XX International Conference, pp. 2716-2721, November 2012.
- [3] P. E. Todmal and S. Melzi, "Electromagnetic regenerative suspension system for ground vehicles," *Renewable Energy Research and Applications (ICRERA)*, 2015 International Conference, pp. 432-437, February 2016.
- [4] J. Mondal, B. Azzam, and M. Abuhalaifa, "Active Tuned Mass Damper," *Control and Automation (MED)*, 2015 23th Mediterranean Conference, pp. 1192-1197, July 2015.
- [5] D. Hartog, "Mechanical vibrations," Dover publications, inc., New York, 1985.
- [6] ESM Energy Ltd., retrieved September 17, 2017 from: https://www.esm-gmbh.de/EN/Products/Tuned_mass_dampers
- [7] T. Beek, K. Pluk, and H. Jansen, "Optimization and measurement of eddy current damping in a passive tuned mass damper," *IET Electric Power Applications*, Vol. 10, pp. 641-648, July 2016.
- [8] M. F. Gardner, "Operational calculus," *Electrical Engineering*, Vol.: 53, pp. 1339-1347, October 1934.
- [9] M. F. Heertjes, M. L. J. Ven, and R. Kamidi, "Acceleration-snap feedforward scheme for a motion system with viscoelastic tuned-mass-damper," *American Control Conference (ACC)*, pp. 2888-2893, July 2017.
- [10] X. Tong, X. Zhao, "Vibration suppression of the finite-dimensional approximation of the non-uniform SCOLE model using multiple tuned mass dampers," *Decision and Control (CDC)*, 2016 IEEE 55th Conference, pp. 4797-4802, December 2016.
- [11] G. Barone, F. L. Iacono, and G. Navarra, "Dynamic characterization of fractional oscillators for Fractional Tuned Mass Dampers tuning," *Fractional Differentiation and Its Applications (ICFDA)*, 2014 International Conference, pp. 97-102, December 2014.