

# Genetic Algorithm Optimization of a Small Scale Natural Gas Liquefaction Process

M. I. Abdelhamid, A. O. Ghallab, R. S. Ettouney, M. A. El-Rifai

**Abstract**—An optimization scheme based on COM server is suggested for communication between Genetic Algorithm (GA) toolbox of MATLAB and Aspen HYSYS. The structure and details of the proposed framework are discussed. The power of the developed scheme is illustrated by its application to the optimization of a recently developed natural gas liquefaction process in which Aspen HYSYS was used for minimization of the power consumption by optimizing the values of five operating variables. In this work, optimization by coupling between the GA in MATLAB and Aspen HYSYS model of the same process using the same five decision variables enabled improvements in power consumption by 3.3%, when 77% of the natural gas feed is liquefied. Also on inclusion of the flow rates of both nitrogen and carbon dioxide refrigerants as two additional decision variables, the power consumption decreased by 6.5% for a 78% liquefaction of the natural gas feed.

**Keywords**—Stranded gas liquefaction, genetic algorithm, COM server, single nitrogen expansion, carbon dioxide pre-cooling.

## I. INTRODUCTION

LIMITED natural gas resources, which are remote from markets and not in the proximity of existing pipelines, are known as stranded gas and have until recently been considered as commercially unattractive. With the expected increase of natural gas demand averaging at 1.9-2.7% per annum [1], the recovery of stranded gas has acquired a growing importance [2] both from economic and environmental points of view. Alternative processes for recovering stranded gas range from gas to wire (GTW), in which the stranded gas is used on site to generate electric power which can be transported through power lines to the nearest onshore or offshore facilities [3], to volume reduction via a variety of chemical and physical processes to facilitate its transportation. These include conversion of the stranded gas by steam reforming followed by Fischer-Tropsch synthesis of high quality liquid fuels [4], gas to solid schemes in which natural gas hydrates (NGH) are produced by combination of natural gas with water under high pressure [5], [6], and liquefaction using different refrigeration schemes to produce liquefied natural gas (LNG) whose volume is 600 times smaller than the gas volume at room temperature [7].

A number of alternative refrigeration systems have been

applied in the liquefaction of stranded gas. Nitrogen expansion refrigeration processes were first used for offshore liquefaction facilities due to their compact size, ease of operation, adaptability to variable feed conditions, inherent safety, and their reduced plot space [8]. The main drawback of nitrogen expansion refrigeration cycles compared with the cascade and mixed refrigerant processes is their high energy demand [9]. This prompted work on optimization of the nitrogen expansion processes with a view to minimizing the specific power consumption required to liquefy the natural gas feed. A simplified process model [10] assuming constant specific heat and ideal gas behavior and a more rigorous model based on the Soave-Redlich-Kwong (SRK) equation of state was proposed to study the optimization of the single nitrogen expansion cycle using a sequential quadratic programming (SQP) method. The minimization of specific power consumption in single and dual nitrogen expansion processes [11] was also studied by selecting the process variables affecting power consumption as the decision variables.

Another direction towards reducing specific power consumption is the inclusion of pre-cooling refrigeration cycles. The inclusion of propane and R410a refrigerants pre-cooling cycles [12] enabled improved performance. The optimization of a system with an added carbon dioxide pre-cooling cycle to the single nitrogen expansion process has been suggested as an alternative for offshore LNG applications [13]. The study is based on a more extensive analysis of the effect of process variables on the power consumption of the  $N_2$ - $CO_2$  cycle. A flexible single  $N_2$  expansion-refrigeration process with  $CO_2$  pre-cooling was proposed [14]. The optimization of this system was carried out using Aspen HYSYS taking the liquefaction rate as a constraint and setting energy consumption as the objective function.

Aspen HYSYS was also used to analyze the propane pre-cooled mixed refrigerant [15]. In this work, the objective functions were categorized into two groups; operation and design. These were tested and optimized with the HYSYS optimizer tool using BOX method to identify the objective function with the most influence on the efficiency of the studied process. No stochastic optimization techniques such as genetic algorithm were used in this study, which only used the built-in optimizer tool inside Aspen HYSYS.

Stochastic optimization techniques have been also used in synthesis and optimization of different natural gas liquefaction processes mostly based on GA [16], [17]. A hybrid optimization methodology [18] which combined GA and

M. I. Abdelhamid is Teaching and Research Assistant in Chemical Engineering Department, Cairo University, Egypt (Phone: +20 (102) 225 0415, e-mail: mohamed.ibrahim@eng1.cu.edu.eg).

M. A. El-Rifai and R.S. Ettouney are Professors in Chemical Engineering Department, Cairo University, Egypt (e-mail: melrifai@eng1.cu.edu.eg; ettouney@eng1.cu.edu.eg).

A. O. Ghallab is Assistant Professors in Chemical Engineering Department, Cairo University, Egypt (e-mail: ayatossama@hotmail.com).

sequential quadratic programming (SQP) was used to optimize the mathematical model of the dual mixed refrigerant (DMR) process. The optimum operating conditions were achieved by the proposed optimization framework in order to minimize the required power consumption to liquefy the natural gas feed. GA was used to minimize energy consumption in the single mixed refrigerant process taking the composition of the mixed refrigerant and the pressures of refrigerant evaporation and condensation as decision variables [19]. The algorithm was coded using visual basic and the refrigeration system simulated with Aspen Plus. The communication between visual basic and Aspen Plus was carried out via ActiveX technology.

Other approaches relied on Microsoft's component object model (COM) server to communicate HYSYS with the GA toolbox of MATLAB. COM is the basis of other Microsoft technologies and frameworks such as Object Linking and

Embedding (OLE), OLE Automation, and ActiveX. COM is a tool for using objects in an environment different from the environment in which the object was created [20].

The above methodology was applied to the optimization of the propane pre-cooled mixed refrigerant (C3-MR) process [21]. Significant reduction in the power consumption of the propane pre-cooling cycle and of the mixed refrigerant liquefaction cycle was obtained. The power consumption in the mixed refrigerant cycle and the nitrogen expansion process with expanders in parallel configuration [22] has been optimized through HYSYS simulation and GA. This scheme provided for better energy efficiency. The HYSYS-MATLAB interface was applied [23] to minimize the power consumption in the propane pre-cooled  $N_2$ - $CH_4$  expander process. However, none of the above studies presented details of the COM server used for coupling between simulation and optimization software.

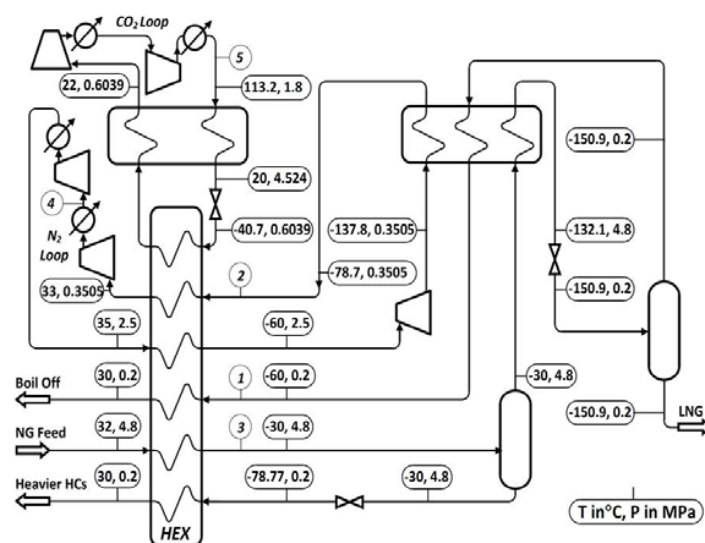

Fig. 1 Single  $N_2$  expansion with  $CO_2$  pre-cooling gas liquefaction process

In this work a scheme is proposed for the communication between the GA toolbox of MATLAB and ASPEN HYSYS via COM. It is applied to a small-scale liquefaction process adopting the single  $N_2$  expansion with  $CO_2$  pre-cooling. The advantage of the proposed COM will be illustrated by comparison with the results obtained in the work of Yuan et al. [14].

## II. THE STUDIED SYSTEM

Fig. 1 indicates the location of the above five decision variables on the corresponding process streams. The simulation of this system using HYSYS is based on calculating the phase equilibria and enthalpy using Peng Robinson and Lee-Kesler-Plocker equations, respectively. The adiabatic efficiency of the compressors was taken at 85% and that of the turbo-expander at 80%. The heat exchangers' pressure drop is neglected.

Feed gas composition, pressure, temperature, and flow rate

and the nitrogen and  $CO_2$  flow rates were kept constant.

In this work, the same constraints on the decision variables, [14] corresponding to the conditions indicated in Fig. 1, will be adopted. The minimum temperature approach of the heat exchange trains is taken as 2K which is generally recommended for plate fin heat exchangers used in gas liquefaction applications. Also, the compression ratio of the four compressors has been constrained to lie between 2-3.

The optimization objective is to minimize the input energy requirements per mole of liquefied natural gas. If  $W_c$  is the power required by a compressor (kW),  $W_t$  is the power generated by the turbine (kW), and  $m_{LNG}$  is the liquefied natural gas throughput (mole  $s^{-1}$ ), the optimization objective may be stated as the minimization of the performance index (I):

$$I = [(\sum W_c - \sum W_t) / m_{LNG}] \quad (1)$$

The minimization of the objective function through Aspen

HYSYS optimizer resulted in a minimum power consumption of 35.64 kW mole<sup>-1</sup>s (9.9 kW kmole<sup>-1</sup> h) [14].

The following sections illustrate the optimization of the above Aspen HYSYS modeled stranded gas liquefaction process through the GA in MATLAB toolbox.

### III. SUGGESTED OPTIMIZATION FRAMEWORK

MATLAB has been configured to control the custom interface server of Aspen HYSYS by creating a COM object through the command (actxserver) [24]. Data exchange between MATLAB and HYSYS has been implemented by creating a code structured according to the steps explained below and as shown in Fig. 2.

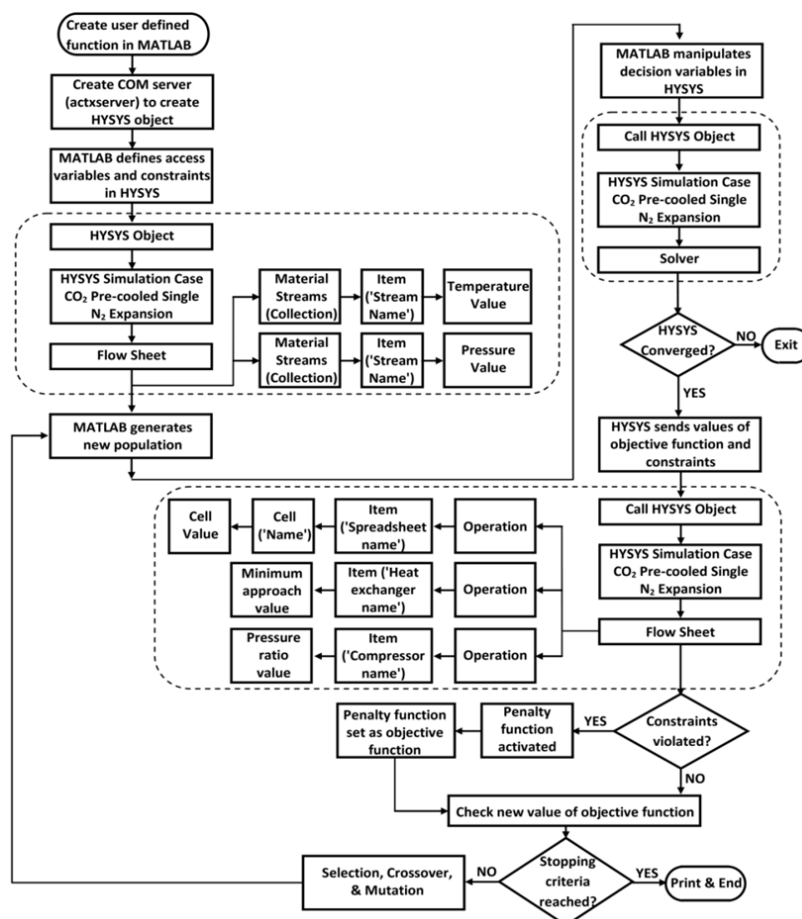

Fig. 2 Optimization of HYSYS flow sheet using GA toolbox of MATLAB

1. MATLAB (actxserver) command uses COM to create a local automation server to run HYSYS.
2. The COM server enables MATLAB to access HYSYS object library to read and write the values of the built-in HYSYS objects and class members. Fig. 2 shows the framework for optimization of a HYSYS flow sheet using GA toolbox of MATLAB. The details of the code used to access HYSYS data of any stream, equipment or spreadsheet through COM server are incorporated inside the shown dashed boxes.
3. The values of the objective function, the decision variables, and constraints are defined inside the spreadsheet operation of HYSYS and are accessed through the generated COM server.
4. The GA toolbox creates a new population of chromosomes containing various genes. Each chromosome represents a possible solution vector with the genes representing the suggested values of each decision variable. It then searches for the regions where the value of the objective function decreases continuously. The GA operators such as population size, selection, and crossover probability affect the accuracy and computational time required to reach the optimum solution. The GA performs selection, crossover, and mutation for the decision variables to generate a newer population as long as the stopping criterion is not met
5. In case of violation of a constraint, the algorithm changes its search region by suggesting new values for the decision variables to avoid further constraint violation. This is automatically achieved by defining a penalty

function. The penalty function remains inactive as long as all the constraints are not violated; otherwise, the following penalty function is activated:

$$P = F + A.G \quad (2)$$

where P is the value of the penalty function when one of the constraints is violated, F is the current value of the objective function, A is the initial value of the objective function before starting the GA optimization framework, and G is the largest value of a function (S) which contains the current normalized values of the constraints. It is calculated when one of the constraints exceeds its limiting value from:

$$S = [(\Delta P_i/3), (1 + 3/ \text{Abs}(\Delta t_j))] \quad (3)$$

where  $\Delta P$  is the pressure ratio of  $i^{\text{th}}$  compressor and  $\Delta t$  is the temperature approach of  $j^{\text{th}}$  heat exchanger.

6. The activation of the penalty function involves the simultaneous addition of a penalty term to the objective

function. The GA adjusts its parameters to avoid this scenario.

#### IV. RESULTS AND DISCUSSION

The above proposed optimization framework has been applied to the process shown in Fig. 1. All the fixed operating parameters, decision variables, and constraints referred to in Section II will be retained [14]. An appropriate range of variation has been specified for each of the decision variables to be optimized. Also, the effect of including two additional decision variables to be optimized namely the flow rates of both the nitrogen and CO<sub>2</sub> refrigerants will be illustrated. The population size was set at 120, the crossover probability was selected to be 0.8, and the tournament selection technique of size 4 was chosen as the selection process.

The evolution of the power consumption calculated through 51 generations of the GA framework are depicted in Figs. 3 and 4, in which 5 and 7 decision variables are considered, respectively.

TABLE I  
OPTIMIZATION RESULTS FOR CO<sub>2</sub> PRE-COOLED SINGLE N<sub>2</sub> EXPANSION PROCESS

Decision Variables	HYSYS Optimized, 5 decision variables [14]	GA Optimized, 5 decision variables	GA Optimized, 7 decision variables
Temperature of stream (1),K	243.15	248.038	246.8397
Temperature of stream (2),K	213.15	220.8611	220.7604
Temperature of stream (3), K	213.15	207.5639	202.1949
Pressure of stream (4), Pa	950000	961197.1	951611
Pressure of stream (5), Pa	1800000	1922108	1986860
Throughput of stream (4), mole s-1	6	6	5.8815
Throughput of stream (5), mole s-1	0.2778	0.2778	0.1452
Power consumption, kW mole-1 s	35.64	34.479	33.3288
Reduction in power consumption, %	---	3.2576	6.4848
Reduction in power consumption, %			
$w, W$ energy density	1 erg/cm <sup>3</sup> → 10 <sup>-1</sup> J/m <sup>3</sup>		
$N, D$ demagnetizing factor	1 → 1/(4 $\pi$ )		

No vertical lines in table. Statements that serve as captions for the entire table do not need footnote letters.

<sup>a</sup>Gaussian units are the same as cgs emu for magnetostatics; Mx = maxwell, G = gauss, Oe = oersted; Wb = weber, V = volt, s = second, T = tesla, m = meter, A = ampere, J = joule, kg = kilogram, H = henry.

Table I summarizes the optimized values of the decision variables pertaining to the streams numbered in Fig. 1 and calculated by alternative optimization schemes. The HYSYS optimized values [14] are reproduced in the second column of the table. The third column of the table gives the corresponding values calculated by combining HYSYS and the GA tool box of MATLAB. The values of the decision variables obtained on addition of two more decision variables namely the flow rates of the N<sub>2</sub> and CO<sub>2</sub> refrigerants in the GA optimization scheme are presented in the fourth column.

It is seen that compared to the HYSYS optimized system, the GA optimized system corresponds to a 3.2576% reduction in power consumption when 77% of the natural gas feed is liquefied. Also, when 7 rather than 5 decision variables are used in the GA, the power consumption drops by 6.4848% and a 78% liquefaction of the natural gas feed is obtained.

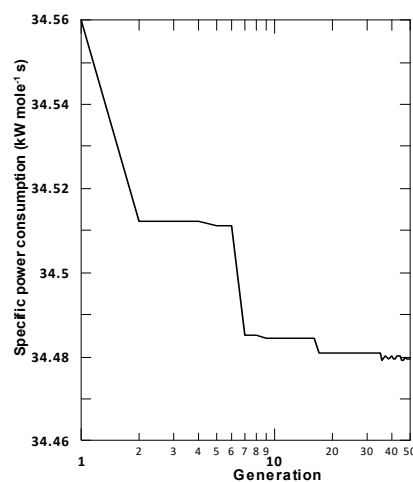

Fig. 3 GA convergence curve for 5 decision variables

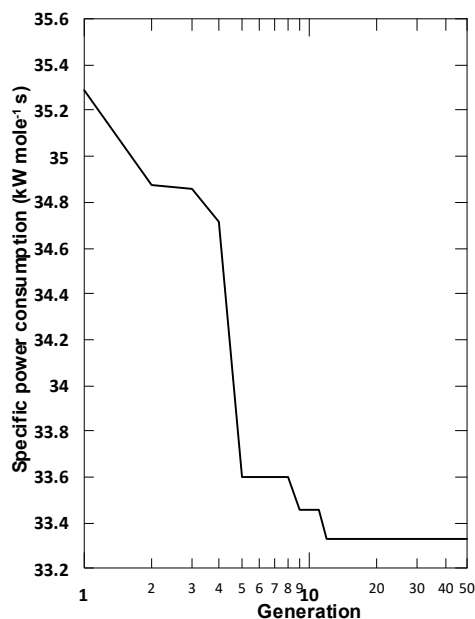

Fig. 4 GA convergence curve for 7 decision variables

#### V. CONCLUSION

Nitrogen expansion based stranded gas liquefaction processes feature safety, flexibility, and ease of operation. They are however, characterized by relatively high energy requirements. This points to the importance of optimization studies aiming at minimizing their power consumption.

Although Aspen HYSYS contains an embedded traditional optimizer tool, it does not contain a genetic algorithm (GA) toolbox to avoid trapping in local optima. In this work, component object model (COM) server is proposed for coupling Aspen HYSYS and MATLAB GA toolbox through an interface with bidirectional data communication.

The strength of the proposed scheme is illustrated by its application to the single nitrogen expansion process with CO<sub>2</sub> pre-cooling recently suggested for natural gas liquefaction. Compared to the traditional HYSYS optimizer, it enabled the decrease in power consumption by 3.2576% for the same liquefaction fraction of 0.77, and a five component vector of decision variables. The inclusion of two more decision variables enabled to reduce the power consumption by 6.4848% with a liquefaction fraction of 0.78.

The proposed GA-HYSYS framework can be readily extended to the optimization of other process systems characterized by non-linearities and a large number of decision variables.

#### REFERENCES

- [1] BP Energy Outlook 2035, 2014 Ed. BP's Energy Outlook, 2014.
- [2] W. Lim, K. Choi, I. Moon, Current Status and Perspectives of Liquefied Natural Gas (LNG) Plant Design, *Ind. Eng. Chem. Res.* 52 (2013) 3065–3088.
- [3] S. Mokhatab, W. A. Poe, J. G. Speight, *Handbook of Natural Gas Transmission and Processing*, Gulf Professional Publishing, 2006.
- [4] D. Wood, C. Nwaoha, B. F. Towler, Gas-to-liquids (GTL): A review of an industry offering several routes for monetizing natural gas, *J. Nat.*

- Gas Sci. Eng.* 9 (2012) 196–208.
- [5] K. Nazari, Z. Taheri, M. Mehrabi, R. Khodafarin, Natural Gas Hydrate Production and Transportation, *Proceedings of the 7th International Conference on Gas Hydrates (ICGH 2011)*, Edinburgh, Scotland, UK, 2011.
- [6] D. Sloan, C. Koh, A. K. Sum, *Natural Gas Hydrates in Flow Assurance*. Gulf Professional Publishing, 2010.
- [7] X. Wang, M. Economides, *Advanced Natural Gas Engineering*, Gulf Publishing Company, 2009.
- [8] A. J. Finn, *Effective LNG Production Offshore*, 81st Annual GPA Convention, Dallas, 2002.
- [9] A. J. Finn, G. L. Johnson, T. R. Tomlinson, *LNG Technology for Offshore and Mid-Scale Plants*, 79th Annual GPA Convention, Atlanta, 2000.
- [10] B. Austbø, T. Gundersen, Optimization of a single expander LNG process, *Energy Procedia* 64 (2015) 63–72.
- [11] M. S. Khan, S. Lee, M. Getu, M. Lee, Knowledge inspired investigation of selected parameters on energy consumption in nitrogen single and dual expander processes of natural gas liquefaction, *J. Nat. Gas Sci. Eng.*, 23(2015) 324–337.
- [12] T. B. He, Y. L. Ju, A novel conceptual design of parallel nitrogen expansion liquefaction process for small-scale LNG (liquefied natural gas) plant in skid-mount packages, *Energy* 75 (2014) 349–359.
- [13] M.S. Khan, S. Lee, M. Hasan, M. Lee, Process knowledge based opportunistic optimization of the N<sub>2</sub>-CO<sub>2</sub> expander cycle for the economic development of stranded offshore fields, *J. Nat. Gas Sci. Eng.*, 18 (2014) 263–273.
- [14] Z. Yuan, M. Cui, Y. Xie, C. Li, Design and analysis of a small-scale natural gas liquefaction process adopting single nitrogen expansion with carbon dioxide pre-cooling, *Appl. Therm. Eng.* 64 (2014) 139–146.
- [15] P. Hatcher, R. Khalilpour, A. Abbas, Optimisation of LNG mixed-refrigerant processes considering operation and design objectives, *Comput. Chem. Eng.*, 41 (2012) 123–133.
- [16] G. P. Rangaiah, *Advances in Process Systems Engineering-Vol.2 Stochastic Global Techniques and Applications in Chemical Engineering*, World Scientific, 2010.
- [17] S. N. Sivanandam, S. N. Deepa, S. N., *Introduction to Genetic Algorithms*, Springer Science & Business Media, 2007.
- [18] J. H. Hwang, M. I. Roh, K. Y. Lee, Determination of the optimal operating conditions of the dual mixed refrigerant cycle for the LNG FPSO topside liquefaction process, *Comput. Chem. Eng.*, 49 (2013) 25–36.
- [19] L. Cao, J. Liu, X. Xu, Robustness analysis of the mixed refrigerant composition employed in the single mixed refrigerant (SMR) liquefied natural gas (LNG) process, *Appl. Therm. Eng.* 93 (2016) 1155–1163.
- [20] The Component Object Model (COM) (2015). Available from: [https://msdn.microsoft.com/en-us/library/windows/desktop/ms694363\(v=vs.85\).aspx](https://msdn.microsoft.com/en-us/library/windows/desktop/ms694363(v=vs.85).aspx). Accessed 8.14.15.
- [21] A. Alabdulkarem, A. Mortazavi, Y. Hwang, R. Radermacher, P. Rogers, Optimization of propane pre-cooled mixed refrigerant LNG plant, *Appl. Therm. Eng.*, 31 (2011) 1091–1098.
- [22] T. B. He, Y.L. Ju, Performance improvement of nitrogen expansion liquefaction process for small-scale LNG plant, *Cryogenics*, 61 (2014) 111–119.
- [23] H. Ding, H. Sun, M. He, Optimisation of expansion liquefaction processes using mixed refrigerant N<sub>2</sub>-CH<sub>4</sub>, *Appl. Therm. Eng.*, 93 (2016) 1053–1060.
- [24] Create COM server - MATLAB actxserver (2015). Available from: <http://www.mathworks.com/help/matlab/ref/actxserver.html>. Accessed 8.14.15.