

Multi-Agent System for Irrigation Using Fuzzy Logic Algorithm and Open Platform Communication Data Access

T. Wanyama, B. Far

Abstract—Automatic irrigation systems usually conveniently protect landscape investment. While conventional irrigation systems are known to be inefficient, automated ones have the potential to optimize water usage. In fact, there is a new generation of irrigation systems that are smart in the sense that they monitor the weather, soil conditions, evaporation and plant water use, and automatically adjust the irrigation schedule. In this paper, we present an agent based smart irrigation system. The agents are built using a mix of commercial off the shelf software, including MATLAB, Microsoft Excel and KEPServer Ex5 OPC server, and custom written code. The Irrigation Scheduler Agent uses fuzzy logic to integrate the information that affect the irrigation schedule. In addition, the Multi-Agent system uses Open Platform Connectivity (OPC) technology to share data. OPC technology enables the Irrigation Scheduler Agent to communicate over the Internet, making the system scalable to a municipal or regional agent based water monitoring, management, and optimization system. Finally, this paper presents simulation and pilot installation test result that show the operational effectiveness of our system.

Keywords—Community water usage, fuzzy logic, irrigation, multi-agent system.

I. INTRODUCTION

WORLDWIDE water sources increasingly become strained to keep up with demand as the population grows. In addition, the cost of energy required to move water rises annually. All this is compounded by the fact that in many cities, old water delivery systems designed decades ago to service much smaller populations are inflexible and difficult to maintain. In some countries, water usage fluctuates widely with the seasons. For example, In Canada, municipal water usage doubles in the summer months, because this is when Canadians are outdoors watering lawns and gardens, filling swimming pools and washing cars. The capacity to deliver the required water levels for the summer months must be installed even though it is used for about a quarter of the year. All this leads to the need to develop and deploy water saving techniques. Saving water does not only reduce the cost of water for users, but also leads to a reduced need to upgrade the supply system as well as the reduced cost of energy required to move water; this translates into decreased costs for tax

T. Wanyama is with McMaster University, Faculty of Engineering – W. Booth School of Engineering Practice and Technology, Hamilton, ON, Canada (e-mail wanyama@mcmaster.ca).

B. Far is with University of Calgary, Schulich School of Engineering, Department of Electrical and Computer Engineering, Calgary, Alberta, Canada (e-mail far@ucalgary.ca)

payers.

Irrigation is a highly visible water use; and it is usually the first to be regulated when water becomes scarce. Therefore, it makes sense to focus on an irrigation system to reduce water usage. Ironically, automatic irrigation systems are one of the largest causes of over-watering, since the controllers are usually set to apply the peak irrigation requirements of the year. Thereafter, they are adjusted on average two to three times a year, and many are not adjusted at all. As a result, the average automatic system applies up to three times the amount of water required by the landscape. This has led to the development of a new generation of smart irrigation systems that monitor weather, soil conditions, evaporation, and plant water use, and automatically adjust the irrigation schedule and controller settings. It is in line with this trend that we have developed an agent-based irrigation system. The system has the following agents:

- Irrigation Scheduler Agent – This agent sets the irrigation schedule, and it is responsible for collaborating with other irrigation systems.
- Weather Agent – This agent reads local weather information from a website and makes it available to other agents as well as human users.
- Plant Watering and Monitoring Agent – This agent waters and monitors the health of the plants or lawn. Later, it will be updated to monitor plant water and fertilizer usage.

The three agents share information through a global data base that is supported by an OPC server. The server also functions as an information highway over the Local Area Network (LAN) for the agents. Using a multi-agent system allows each component of the irrigation system to focus on a specific role, increasing the flexibility, functionalities, and scalability of the system. For example, in the future we would like to use a single Irrigation Scheduler Agent to manage multiple irrigation systems. This shall be achieved by using OPC Unified Architecture to provide an information highway over the Internet.

The rest of this paper is arranged as follows: Section II covers the motivation for developing water saving methods for irrigation systems, as well as the appropriateness of using a multi-agent approach to model irrigation systems. In Section III we present the proposed agent based irrigation system and Section IV deals with the testing and results of the case study. Section V covers the conclusion.

II. MOTIVATION

There are two main types of irrigation system, namely: low flow and high flow. Low flow irrigation systems include micro spray, drip emitters, and drip lines; while high flow irrigation systems include fixed spray, rotor, impact, bubbler, and soaker hose. But it is generally agreed in literature that no matter the type of irrigation system, the use of smart technology can reduce their water usage by up to 80% [5].

Many smart systems have been proposed in literature. Some of these system use hardware that is susceptible to weather changes, while others are optimized for specific plants or crop. Darshna et al. propose a smart system that monitors soil moisture and temperature and uses predefined moisture-temperature profiles of plants to control the irrigation schedule [5]. Harishankar et al. present control system that is suitable for low flow irrigation systems. It uses the soil moisture level as input to the unit that controls a stepper motor. In response to the soil moisture level, the stepper motor slowly open or closes the irrigation valve so as to maintain a predefined moisture level (setpoint) [6]. HydroPoint has developed one of the most sophisticated weather-based irrigation systems. The system has a super computer that simulates the local weather conditions of every square kilometer across North America. The computer sends weather related information to the boxes that control specific zones of the clients' irrigation system. Then microcontrollers in the control boxes use the weather information to determine how much and when to water their zones [1].

Most, if not all smart irrigation systems reviewed in the literature are viable solutions for saving water. However, they focus on saving water for single isolated agriculture fields, lawns or parks, without any form of collaboration with other irrigation systems so as to achieve global water optimization. The scheduler agents of the different agent-based irrigation system described in this paper can collaborate with each other,

and with the water source agent to optimize community water usage. The multi-agent model fits well with irrigation systems because of the following:

- Agents in a community can share information on how to best ration the water in case of shortages.
- Each agent in the system can be a specialist in its area of expertise, providing extra services beyond water optimization. For example, the weather agent can provide weather information to users that can be utilized for travel or recreation planning. The plant watering and monitoring agent can provide farmers with information about plant health as well as water and fertilizer usage.
- Smart irrigation systems involve integration of a large number of distributed devices, some of which may be designed to satisfy conflicting objectives. Moreover, multiple sensing/computing platforms, such as Programmable Logic Controls (PLCs), microcontrollers, and PCs may be used [4].

An agent is an independent hardware/software entity which has the ability to understand a situation, and respond to stimulations from its environment according to its individual behavior [4], [2]. It can interact with other agents and with humans, which means that an agent can provide services and request for services [2]. Usually, an agent has its own specializations such as sensing, action, decision making, and database management. If multiple agents are deployed together, they can share information and collaborate so as to achieve common goals [4]. This can only happen through some kind of communication language or interface. In our agent-based irrigation system, we use OPC technology to provide the communication interface. The OPC setup of the proposed system involves an OPC server and client on an Ethernet network [3]. The agents share information among themselves through an OPC interface supported by an OPC server, and humans share information with an agent through a Human Machine Interface (HMI) provided by an OPC client.

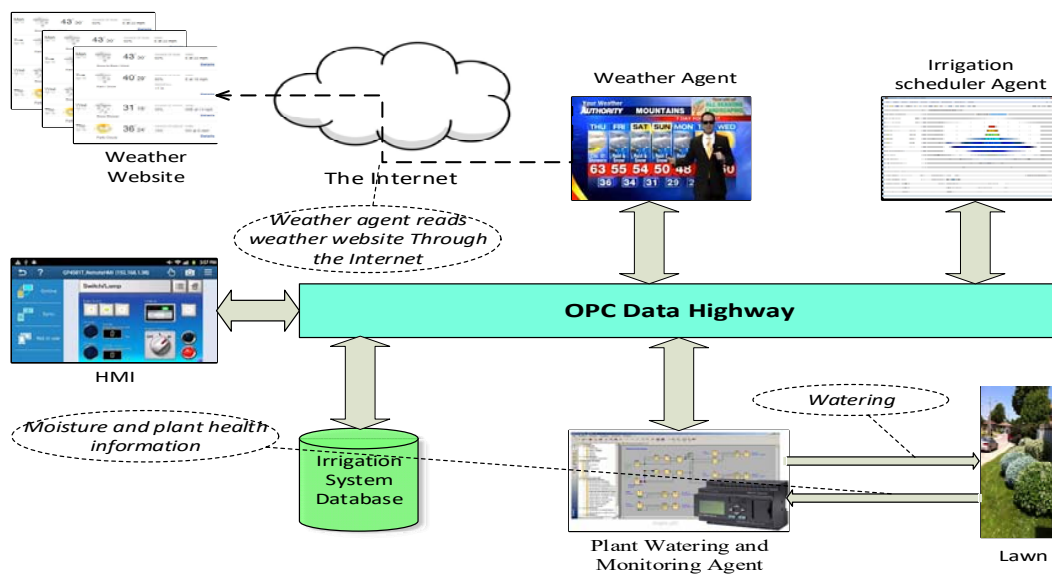

Fig. 1 Architecture of a Multi-Agent based Irrigation System

III. MULTI-AGENT BASED IRRIGATION SYSTEM

The Canada Mortgage and Housing Corporation recommends that before watering, to always take into account the amount of water Mother Nature has supplied to your lawn or garden in the preceding week. However, the proposed system presented in his paper does not only take into account the water that Mother Nature has already supplied to the lawn, but also the water she will soon supply. Moreover, the system is based on multi-agent system modeling such that it can be scaled to control and monitor community, municipality, or regional irrigation water usage.

Fig. 1 shows the multi-agent architecture of the irrigation system. The agents are based on Commercial Off-The-shelf

(COTS) software and hardware. For example, the Irrigation Scheduler agent uses the Fuzzy Logic toolbox in MATLAB application to determine the irrigation schedule, while the Weather agent uses the Microsoft Excel application to read information from a local weather website. In addition, the system uses KEPServer Ex5 OPC server as the information highway. Fig. 2 shows the deployment diagram of the irrigation system. The Irrigation Scheduler and the Weather agents are deployed on a personal computer that has Internet access, and has MATLAB and Microsoft Excel installed on it.

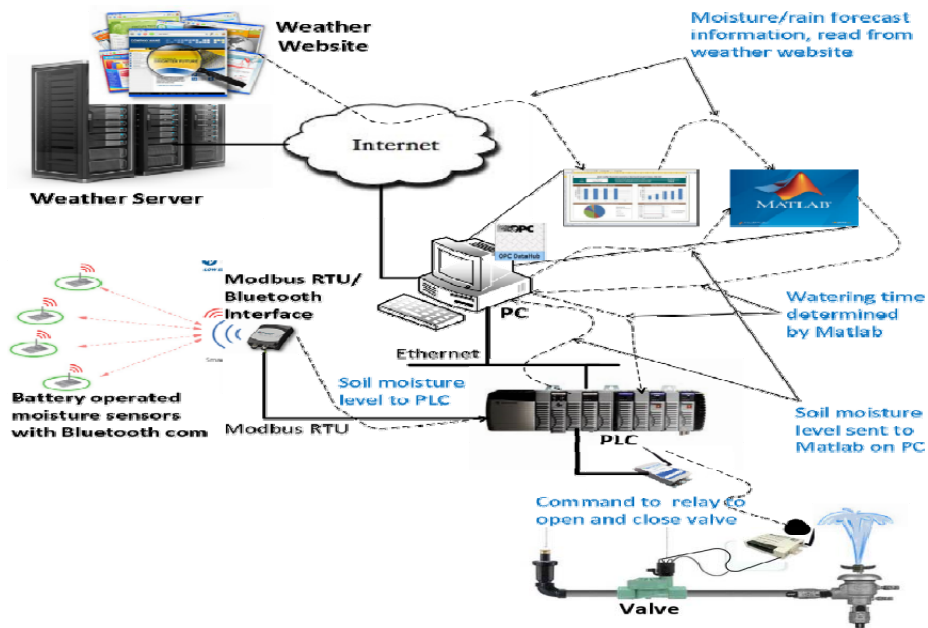

Fig. 2 Deployment Diagram of Smart Irrigation System

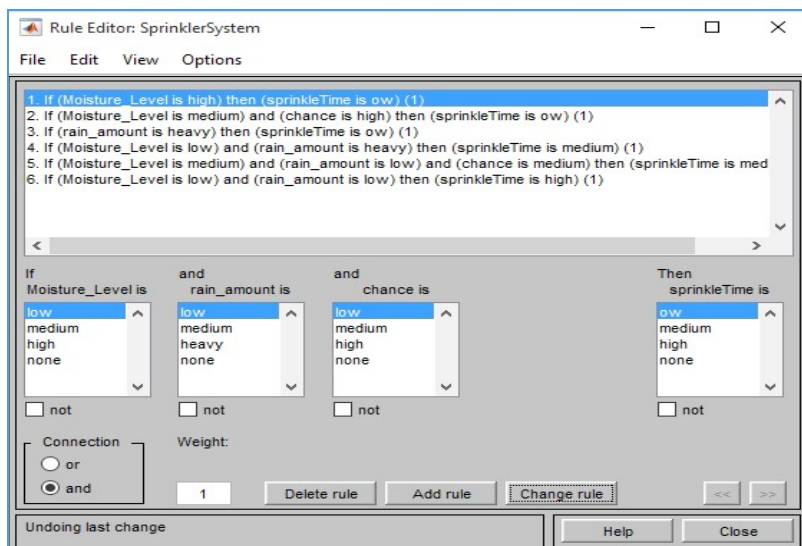

Fig. 3 Rules based Agent Knowledge

A. Irrigation Scheduler Agent

The Irrigation Scheduler agent uses the fuzzy logic toolbox of the MATLAB application to integrate weather data from the Weather agent and soil moisture data from the Plant Watering and Monitoring agent to calculate the time T required to sufficiently water the lawn. The agent gets its

knowledge from a human irrigation expert and stores it as rules, as shown in Fig. 3. Later, this agent will be upgraded to determine the days of the week and the time of the day irrigation will be done. This will require using extra weather information such as wind speed and direction, as well as extra plant health data including water and fertilizer use.

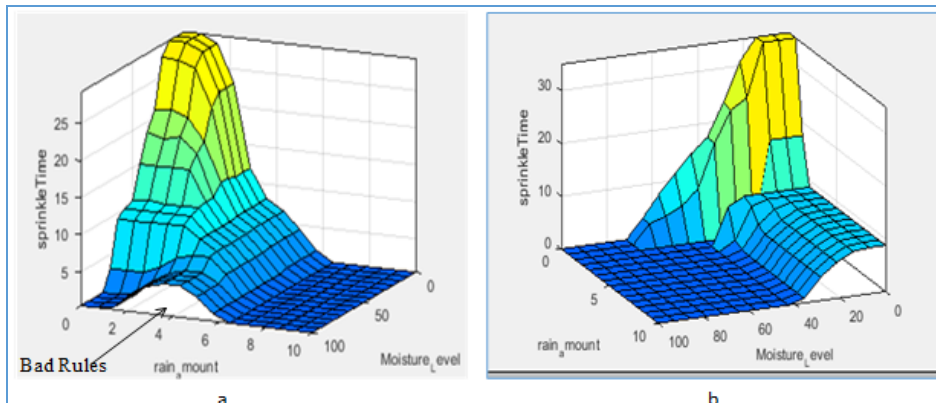

Fig. 4 Diagrammatic Representation Knowledge Rules

A diagrammatic representation of the rules (Fig. 4) allows the agent designer to fine tune them to correctly represent the expert knowledge. For example, Fig. 4 (a) shows that a bad rule had been made that would turn on the sprinkler when there is a lot of moisture in the soil. On the other hand, Fig. 4 (b) shows that when there is little moisture in the soil and it is not expected to rain in the next 24 hours, the lawn is watered for a long time; and if there is a lot of moisture in the soil, the irrigation system is not turned on. In other words, for the Irrigation and Scheduler agent to integrate weather and soil moisture data appropriately, it must have facts about that data. These facts are stored in the agent as membership functions of a fuzzy logic controller. Fig. 5 shows how the agent uses the membership functions of the amount of rain, chance of raining, and soil moisture level, to determine irrigation time T , referred to as sprinkle time in the diagram.

B. Weather Agent

The Weather agent reads local weather information from a website using Microsoft Excel macro-instructions and makes it available to users through an Excel workbook, and to other agents through the OPC Dynamic Data Exchange (DDE). In addition, the agent is responsible for cleaning up the worksheet so that statistical parameters such as average rainfall and maximum chance of rain can be calculated. Finally, the agent ensures that weather data sent to the OPC server is of the appropriate data type.

C. Plant Watering and Monitoring Agent

The Plant Watering and Monitoring agent waters plants and monitors the amount of moisture in the soil. Later, this agent will be upgraded to monitor the health of plants or the lawn, as well as plant water and fertilizer usage. The agent is deployed as an Automation Direct CLICK micro PLC. It senses the

moisture level through sensors connected to it using a wireless link and controls the irrigation system valve using a wireless relay, as shown in Fig. 2. The Plant Watering and Monitoring agent gets the irrigation duration T , whenever it needs to use it, from the OPC server through its communication driver. Remember that T is determined by the Irrigation Scheduler agent.

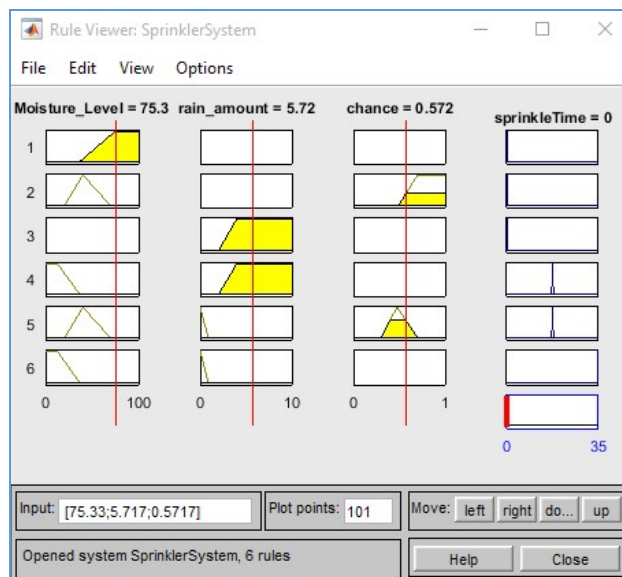

Fig. 5 Membership Functions Representing Facts about Irrigation System Data

IV. TESTING AND RESULTS

We simulated the multi-agent based irrigation system using the Simulink model in Fig. 6. In the simulation, the rain

amount, chance of rain in the next 24 hours, and soil moisture level are assumed to be random.

The simulation generated the results as shown in Fig. 7, which show that the watering time of the smart irrigation

system was above 20 minutes for less than 20% of the watering session; as opposed to water for 30 minutes each (100%) session.

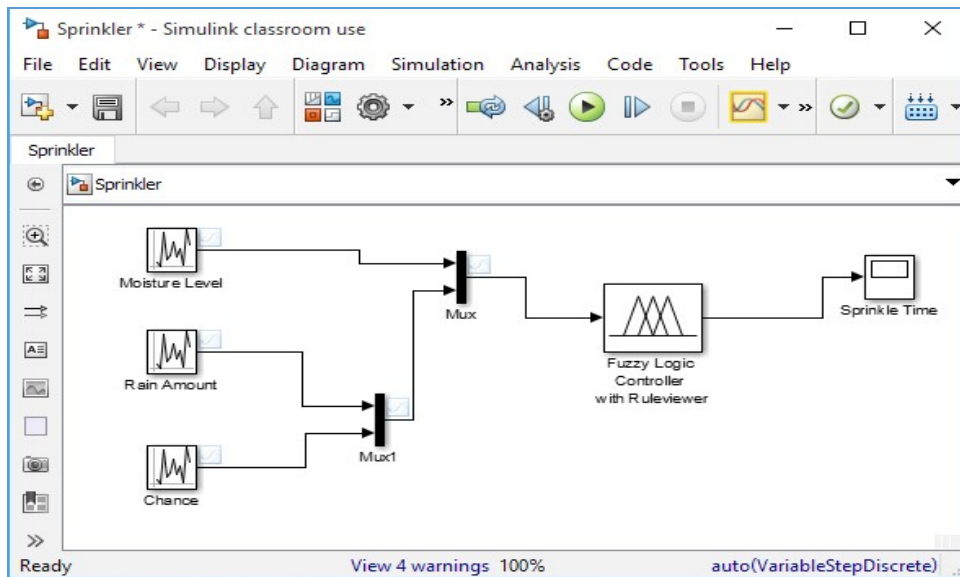

Fig. 6 Simulation of the Intelligent Sprinkler System

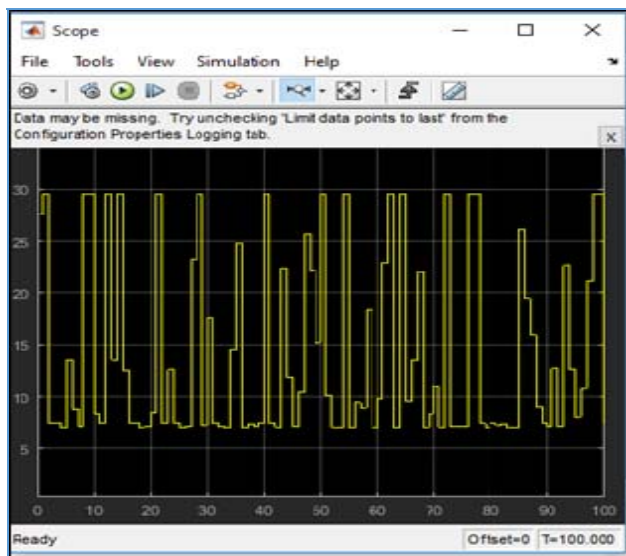

Fig. 7 Results of the Simulation of the Intelligent Sprinkler System

V. CONCLUSION

Irrigation is one of major uses of water, accounting for up to 70% of all the world's fresh water withdraws. Therefore, it is no surprise that many water conservation methods targeting irrigation have been reported in literature. It is in line with these conservation efforts that this paper has proposed a multi-agent based irrigation system. The authors believe that the multi-agent approach is the most appropriate way to model irrigation systems, because these systems usually involve

multiple, distributed, and independent components that need to collaborate to achieve some common goals. Irrigation systems components include, but are not limited to the following systems: weather system, water delivery and monitoring system, soil moisture and plant health monitoring system, and water supply system. Information from all these systems needs to be taken into account in order to optimize irrigation water usage. Besides the support in literature that a system that integrates soil moisture level, amount of expected rain, and chance of rain to determine irrigation duration has the ability to save water, the simulation results of the proposed system confirms it, as shown in Fig. 7. In the future, we would like to improve the performance of the proposed system by taking into account more weather information such as wind speed and direction, and more water data including water availability and community water usage, to determine the irrigation schedule.

REFERENCES

- [1] I. Chen, "Smart Irrigation: A Supercomputer Waters the Lawn - Satellite Control of Company and Municipal Irrigation Systems, Based on Custom Weather Data, Saves Billions of Gallons of Water Nationwide", *Scientific American*, July 2011.
- [2] K. Potiron, A. El Fallah Seghrouchni, P. Taillibert "From Fault Classification to Fault Tolerance for Multi-Agent Systems", *Springer Briefs in Computer Science*, 2013.
- [3] M. S. Mahmoud, M. Sabih, M. Elshafei, "Using OPC technology to support the study of process control", *ISA Transactions*, Elsevier, July 2014.
- [4] Q. Sun, W. Yu, N. Kochurov, Q. Hao; and F. Hu, "A Multi-Agent-Based Intelligent Sensor and Actuator Network Design for Smart House and Home Automation", *Journal of Sensor and Actuator Networks*, August 2013.
- [5] S. Darshna, T. Sangavi, S. Mohan, A. Soundharya, S. Desikan, "Smart

- Irrigation System”, *IOSR Journal of Electronics and Communication Engineering (IOSR-JECE)*, Vol. 10, no. 3, May - Jun.2015. pp. 32-36.
- [6] S. Harishankar, R. S. Kumar, K.P. Sudharsan, U. Vignesh and T. Viveknath, “Solar Powered Smart Irrigation System”, *Advance in Electronic and Electric Engineering*, Vol. 4, no. 4, 2014, pp. 341-346.